

HUKX

Sensor
Technology

User manual
Foil heat flux sensors

FHF05 series

Cautionary statements

Cautionary statements are subdivided into four categories: danger, warning, caution and notice according to the severity of the risk.

DANGER

Failure to comply with a danger statement will lead to death or serious physical injuries.

WARNING

Failure to comply with a warning statement may lead to risk of death or serious physical injuries.

CAUTION

Failure to comply with a caution statement may lead to risk of minor or moderate physical injuries.

NOTICE

Failure to comply with a notice may lead to damage to equipment or may compromise reliable operation of the instrument.

Contents

Introduction	5
1 Ordering and checking at delivery	11
1.1 Ordering FHF05 series	11
1.2 Included items	11
1.3 Quick instrument check	12
2 Instrument principle and theory	13
2.1 What a heat flux sensor is and how it works	13
2.2 Measuring radiation and convection	16
2.3 Selecting a suitable FHF05 heat flux sensor model	16
3 Specifications of FHF05 sensors	18
3.1 Specifications of sensors of the FHF05 series	18
3.2 Dimensions of FHF05 series	24
4 Standards and recommended practices for use	26
4.1 Heat flux measurement in industry	26
5 Installation of FHF05 sensors	27
5.1 Why to avoid air gaps	27
5.2 Site selection and installation	28
5.3 Installation on curved surfaces	31
5.4 Electrical connection	32
5.5 Requirements for data acquisition/amplification	36
6 Maintenance and trouble shooting	37
6.1 Recommended maintenance and quality assurance	37
6.2 Trouble shooting	38
6.3 Validation and calibration	42
7 Appendices	43
7.1 Appendix on cable and cable extension	43
7.2 Appendix on installation of FHF05 sensor foils	45
7.3 Appendix on using FHF05 sensors with BLK – GLD sticker series	48
7.4 Appendix on standards for calibration	49
7.5 Appendix on calibration hierarchy	50
7.6 Appendix on correction for temperature dependence	50
7.7 Appendix on measurement range for different temperatures	51
7.8 Appendix on temperature measurement accuracy	52
7.9 Appendix on use of FHF sensor foils at low temperatures to -200 °C	53
7.10 Appendix on use of FHF sensor foils under vacuum conditions	55
7.11 Appendix on long-term use in condensing, wet, and underwater conditions	56
7.12 Appendix on use of FHF sensor foils under pressure	57
7.13 EU declaration of conformity	58

List of symbols

quantities	symbol	unit
heat flux	Φ	W/m ²
voltage output	U	V
sensitivity	S	V/(W/m ²)
temperature	T	°C
thermal reistance per unit area	$R_{\text{thermal,A}}$	K/(W/m ²)
subscripts		
property of heatsink	heatsink	
maximum value, specification limit	maximum	

Introduction

Looking to measure heat flux? Start your search with the FHF05 series! These heat flux sensors are available in five different dimensions and sensitivities to suit a wide range of applications. They are flexible, have an integrated temperature sensor, and feature thermal spreaders to reduce thermal conductivity dependence. The rated temperature range is from -70 to +120 °C.

This manual offers information on the sensor, the working principle and all you need to know to successfully use it.

FHF05 sensors measure heat flux from conduction, radiation, and convection. Optional black (BLK) and gold (GLD) stickers are available to separate heat transport by radiation from that by convection. In case FHF05 sensors do not meet your specific requirements, explore our [full range of heat flux sensor](#) models for special applications.

Figure 0.1 FHF05-50X50 foil heat flux sensor with thermal spreaders: thin, flexible, and versatile.

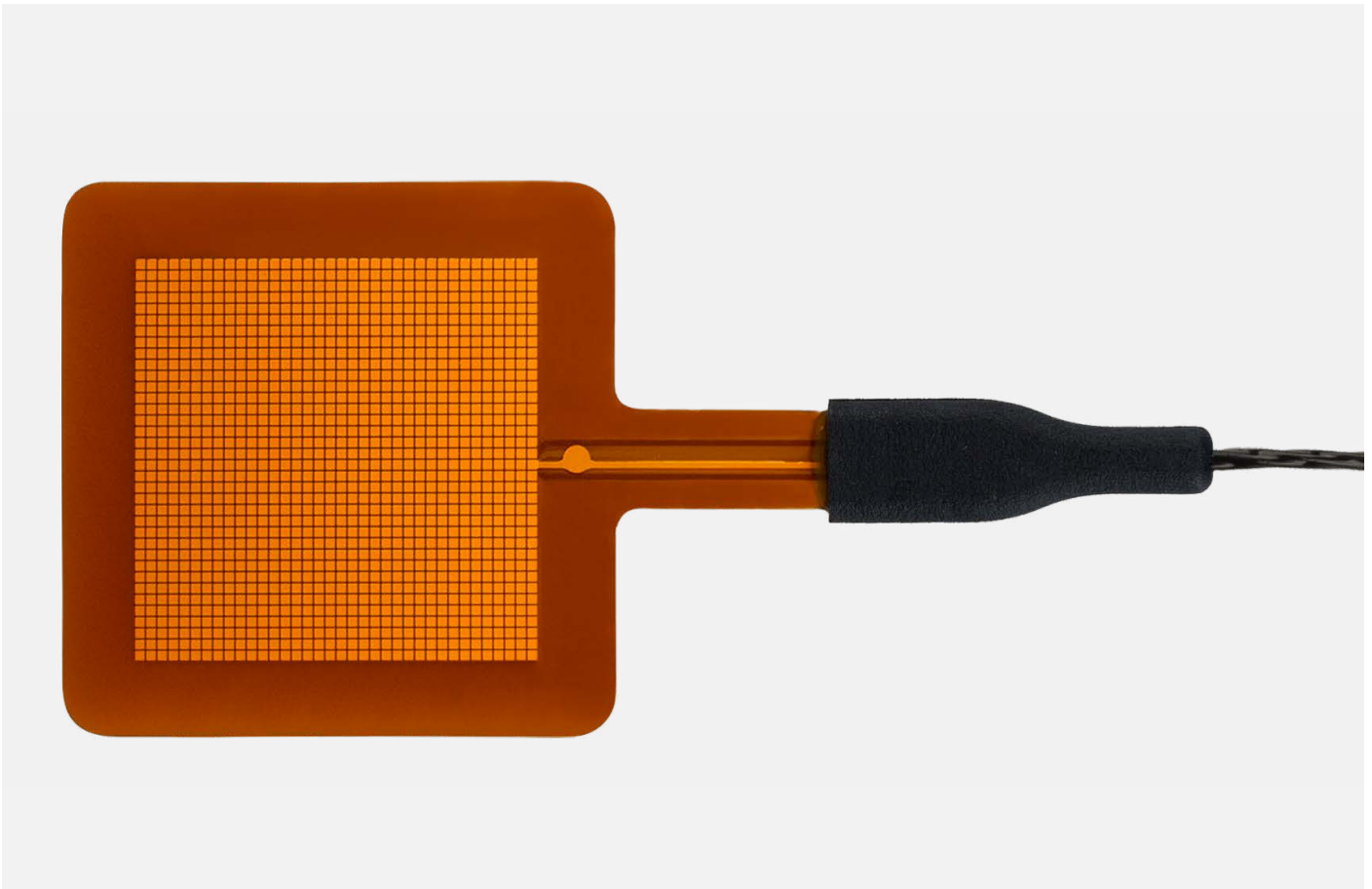

FHF05 series: versatile and suitable for most heat flux measurement applications

FHF05 series heat flux sensors are suitable for general-purpose heat flux measurement. The series consists of sensor models with five different dimensions and sensitivities. Sensors with larger dimensions have a higher sensitivity and a larger area over which the heat flux is averaged.

Thin, flexible, and versatile, FHF05 sensors measure heat flux (in W/m^2) either through the object in which they are incorporated or on which they are mounted. Each sensor contains a thermopile that measures the temperature difference across FHF05's flexible body, which directly translates to heat flux. An integrated Type T thermocouple provides additional temperature measurement. Both the thermopile and thermocouple are passive sensors and do not require external power.

Multiple small thermal spreaders form a conductive layer covering the sensor, reducing the thermal conductivity dependence of the measurement. With these incorporated spreaders, the sensitivity of the FHF05 sensors is independent of the thermal properties of their environment.

Many competing sensors do not have thermal spreaders, so their sensitivity cannot be relied upon since it varies depending on the material on which they are mounted. The passive guard area around the FHF05 sensor reduces measurement errors due to edge effects and may also be used for mounting.

Looking for heat flux and temperature measurement with a heater?
See our [FHF05SC series](#) heat flux sensors.

Using an FHF05 sensor is easy. It connects directly to commonly used data logging systems. The heat flux (in W/m^2) is calculated by dividing FHF05's output, a small voltage, by the sensitivity, which is provided on its certificate.

Robust and stable

FHF05 has proven to be very robust and stable. The instrument is equipped with a potted cable connection block that prevents moisture from entering and also serves as strain relief.



Figure 0.2 Model FHF05-15X85 foil heat flux sensor being installed to measure heat flux on a pipe.

Unique features and benefits

- flexible (bending radius $\geq 7.5 \times 10^{-3}$ m)
- low thermal resistance
- wide temperature range
- fast response time
- large guard area
- integrated Type T thermocouple
- robust design, including cable connection block for strain relief
- IP67 protection rating (essential for outdoor and humid environments)
- integrated thermal spreaders for low thermal conductivity dependence
- sensor foil only: may be used in vacuum environments

Suggested use

FHF05 series sensors can be used for general-purpose heat flux measurement and are often applied as part of a larger test or measuring system.

Typical applications per model

- 10X10: high power microchips
- 15X30: high heat flux in ovens
- 50X50: general-purpose use, battery thermal management
- 15X85: wrapped around a pipe
- 85X85: low heat fluxes, insulation performance testing, use with low accuracy data loggers and amplifiers

Calibration

FHF05 series' calibration is traceable to international standards. The factory calibration method follows the recommended practice of ASTM C1130-21.

Installation

There are various ways to install a heat flux sensor. For more information, see our application note on [how to install a heat flux sensor](#).

Options

- with 5 or 10 m cable lengths
- separate cable in 2, 5, or 10 m lengths
- sensor foil only (without wiring and without connection block)
- **LI19** hand-held read-out unit/data logger
NOTE: LI19 measures heat flux only.
- BLK sticker for all models
(to measure both radiative and convective heat flux)
- GLD sticker for all models
(to measure convective heat flux only)
- BLK and GLD stickers can also be ordered pre-applied at the factory

BLK and GLD sticker series

Want to study energy transport/heat flux in more detail? Hukx helps take your measurement to the next level! Order FHF05 series with radiation-absorbing black and radiation-reflecting gold stickers. You can then use one sensor to measure convective + radiative flux and the other to measure convective flux only. Subtract the two measurements to obtain radiative flux.

Stickers are available for every sensor dimension. For instructions, see the [BLK – GLD sticker series user manual](#) and [installation video](#).

Optionally, these stickers can be ordered pre-applied on FHF05 series sensors.

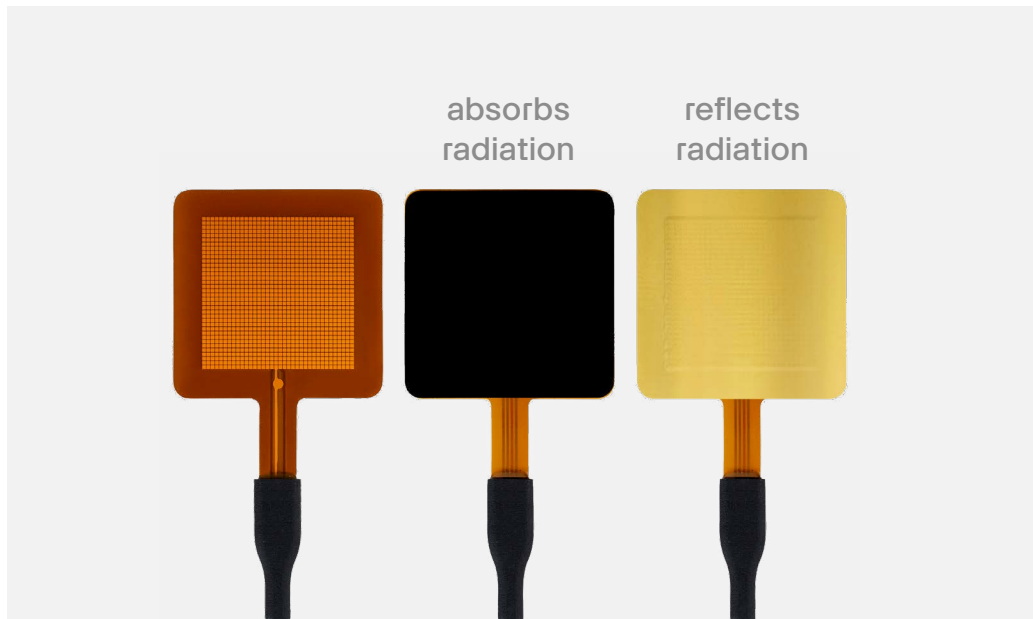

Figure 0.3 FHF05-50X50 with BLK-50X50 and GLD-50X50 stickers.

Suitable electronics

The combined measurement of heat flux and temperature provides a complete picture of the system's thermal behavior. Heat flux sensors produce a small millivolt signal output and are often combined with thermocouples as part of a larger test or measuring system. We have several [preferred solutions](#) for amplification, data logging, and data visualization. To learn more, view our [application notes on sensor amplification](#) or FHF sensors with Hioki data loggers..

Select your FHF model

FHF05 series sensors are available in 5 different sizes.

The following 5-step guide helps you choose the right sensor and electronics for your application and environment. Selecting the right sensor–electronics combination helps reduce total system costs.

Sensors with larger dimensions have:

- a higher sensitivity
- a larger area over which the heat flux is averaged
- a higher price

Step 1

Familiarize yourself with heat flux measurement.
Visit the Hukx YouTube channel:

- [quick intro to heat flux](#) (3 min)
- [online course](#) (40 min)
- [separating radiation and convection](#) (2 min)

Step 2

Verify that FHF05 series sensors are suitable for your heat flux measurement application and environment:

- Check if the heat flux is between -10 to $+10 \times 10^3 \text{ W/m}^2$.
- Confirm that the rated temperature range is below $120 \text{ }^\circ\text{C}$.
- Verify other specifications in the user manual.

Step 3

Determine which FHF05 model/size and optional black and gold stickers may be used:

- Decide if you need a minimum sensor size.
- See which model fits in the available space.
- Check if you want to separate radiation and convection; if so, consider BLK and GLD stickers.

Step 4

Verify that your electronics are compatible:

- Estimate the output range of the heat flux sensor(s) in $[\times 10^{-6} \text{ V}]$ using the sensitivities in the specifications table. NOTE: Microvolt output range = heat flux range in $[\text{W/m}^2] \times$ sensitivity in $[\times 10^{-6} \text{ V}/(\text{W/m}^2)]$.
- Check if your electronics accept analog voltage input.
- Confirm that the microvolt voltage measurement accuracy of your instruments is better than 1% of the sensor output range. This ensures that the electronics are not the limiting factor in measurement accuracy. If your electronics lack sufficient accuracy, consider a larger sensor or connect the sensors in series to create a higher sensitivity.
- Verify that your electronics accept Type T thermocouples. If not, consider whether a temperature measurement is needed or if a separate temperature sensor can be added.

Step 5

Ask Hukx to review your measurement setup:

- Share your application details with us for feedback. Please include: the purpose of the measurement, heat flux source, heat flux sink, expected heat flux and temperature ranges, electronic devices used, and a sketch of the setup with specifications and dimensions.
- Consider alternatives: FHF05 series sensors may not be the best fit. We supply a [wide range of heat flux sensor models](#) optimized for various applications.

See also: FHF05SC

FHF05SC series are self-calibrating versions of the standard FHF05 models, paired with an **HTR02 series** heater. These sensors are used when the highest level of quality assurance is required and for long-term heat flux measurement. The self-calibrating sensor is available in two models: -50X50 and -85X85.

See also

- model **FHF06** for application up to 250 °C
- model **HFP01** (used on walls and in soils as a lower cost alternative to FHF05-85X85)
- heaters of the **HTR02 series**, for verification of performance of FHF-type sensors
- **BLK - GLD sticker series**: to separate radiative and convective heat fluxes
- Hukx offers a complete product range of **heat flux sensors** with the highest quality for any budget

1 Ordering and checking at delivery

1.1 Ordering FHF05 series

The standard configuration of FHF05 series is FHF05-50X05-02, model 50X50 with 2 meters of cable. Common options are:

- model FHF05-10X10
- model FHF05-15X30
- model FHF05-15X85
- model FHF05-85X85
- change -02 to -05 or -10 meters for the respective cable length
- without cable, without cable connection block (sensor foil only)
- with a separate cable of 2, 5, or 10 meters cable length
- with LI19 hand-held read-out unit/data logger;
NOTE: LI19 measures heat flux only, not temperature
- with a heater of the HTR02 series, a foil heater for verification of performance
- with a BLK black sticker (to measure radiative as well as convective heat flux)
- with a GLD gold sticker (to measure convective heat flux only)
- BLK – GLD sticker series can also be ordered pre-applied at the factory for every sensor dimension

1.2 Included items

Arriving at the customer, the delivery should include:

- heat flux sensor FHF05 with cable of the length as ordered
- product certificate matching the instrument serial number

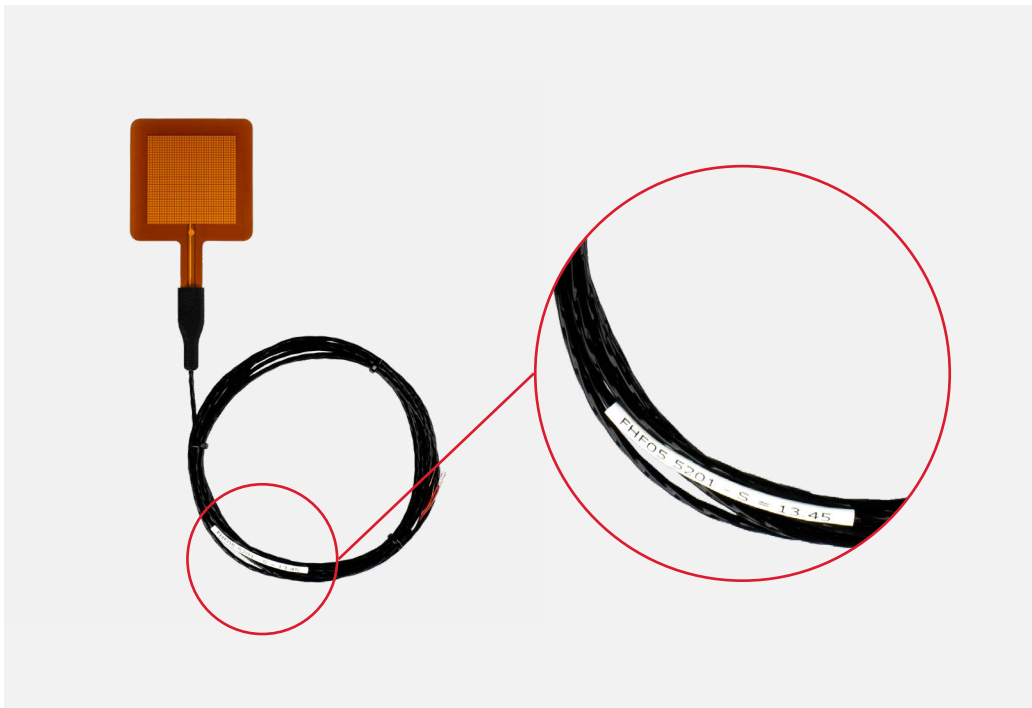

Figure 1.2.1 Model FHF05-50X50 with serial number and sensitivity shown at the end of the cable.

1.3 Quick instrument check

A quick test of the instrument can be done by connecting it to a multimeter.

1. Check the sensor serial number and sensitivity on the label at the end of FHF05's cable against the product certificate provided with the sensor.
2. Inspect the instrument for any damage.
3. Check the electrical resistance of the sensor between the red [+] and black [-] wires. Use a multimeter at the 1k Ω range. Measure the sensor resistance first with one polarity, then reverse the polarity. Take the average value. The typical resistance of the wiring is 0.3 Ω /m. Typical resistance should be the nominal sensor resistance mentioned in Table 3.1.1 (specifications) plus 0.6 Ω for the total resistance of two wires for each meter (back and forth). Infinite resistance indicates a broken circuit; zero or a lower than 1 Ω resistance indicates a short circuit.
4. Check the electrical resistance of the thermocouple between the brown [+] and white [-] wires. Use a multimeter at the 100 Ω range. Measure the thermocouple resistance first with one polarity, then reverse the polarity. Take the average value. The typical resistance of the copper wiring is 0.3 Ω /m, for the constantan wiring this is 6.5 Ω /m. Typical resistance should be the nominal thermocouple resistance of 2.5 Ω plus 6.8 Ω for the total resistance of the two wires of each meter (back and forth). Infinite resistance indicates a broken circuit; zero or a lower than 1 Ω resistance indicates a short circuit.
5. Check if the sensor reacts to heat: put the multimeter at its most sensitive range of DC voltage measurement, typically the 100 x 10⁻³ VDC range or lower. Expose the sensor to heat. Exposing the backside (the side without the dot) to heat should generate a positive signal between the red [+] and black [-] wires. Doing the same at the frontside (the side with the dot), reverses the sign of the output.

2 Instrument principle and theory

2.1 What a heat flux sensor is and how it works

FHF05 sensor's scientific name is heat flux transducer. We use the expression heat flux sensor, because this is more common. A heat flux sensor measures the heat flux density through the sensor itself. This quantity, expressed in W/m^2 , is usually called "heat flux".

FHF05 sensor users typically assume that the measured heat flux is representative of the undisturbed heat flux at the sensor's location. Users may also apply corrections based on scientific judgement.

The sensing element that generates a signal in FHF05's is a thermopile, which formally is a sensor. This thermopile measures the temperature difference across the sensor's polyimide—a plastic body. Working completely passively, the thermopile generates a small voltage that is a linear function of this temperature difference. The heat flux is proportional to the same temperature difference divided by the effective thermal conductivity of the heat flux sensor body.

Using an FHF05 heat flux sensor is easy. For read-out, the user only needs an accurate voltmeter that works in the millivolt range. To convert the measured voltage, U , to a heat flux Φ , the voltage must be divided by the sensitivity S , a constant supplied with each individual sensor.

Figure 2.11 The general working principle of a heat flux sensor. The sensor inside FHF05 series is a thermopile. A thermopile consists of a number of thermocouples, each consisting of two metal alloys (marked 1 and 2), electrically connected in series. A single thermocouple generates an output voltage that is proportional to the temperature difference between its hot and cold joints. Putting thermocouples in series amplifies the signal. In a heat flux sensor, the hot and cold joints are located at the opposite sensor surfaces (4 and 5). In a steady state, the heat flux (6) is a linear function of the temperature difference across the sensor and the average thermal conductivity of the sensor body (3). The thermopile generates a voltage output proportional to the heat flux through the sensor. The exact sensitivity of the sensor is determined at the manufacturer by calibration, and can be found on the product certificate that is supplied with each sensor.

$$\Phi = U/S \quad \text{(Formula 2.1)}$$

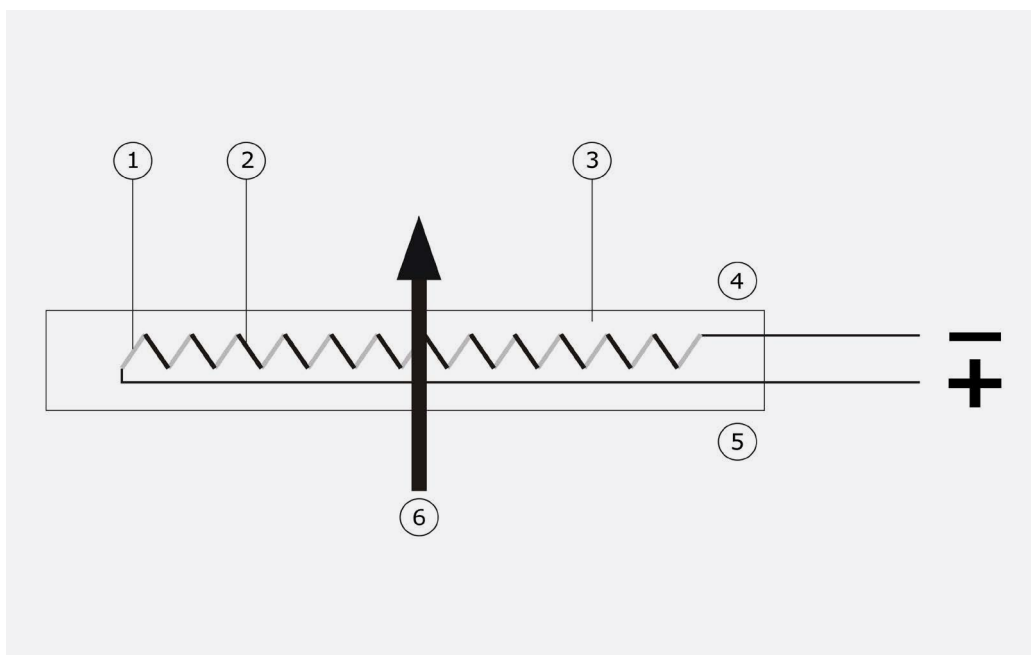



Figure 2.1.2 Heat flux from the backside to the frontside generates a positive voltage output signal. The dot on the foil indicates the frontside.

All FHF05's are designed such that heat flux from the backside to the frontside generates a positive voltage output signal. The dot on the foil indicates the frontside.

Unique features of the FHF05 sensors include flexibility (bending radius $\geq 7.5 \times 10^{-3}$ m), low thermal resistance, a wide temperature range, a fast response time, IP67 protection class rating (essential for outdoor application and use under humid conditions), and thermal spreaders to reduce thermal conductivity dependence.

All FHF05's are calibrated under the following reference conditions:

- conductive heat flux (as opposed to radiative or convective heat flux)
- homogeneous heat flux across the sensor and guard surface
- room temperature
- heat flux in the order of 300 or 600 W/m²
- mounted on aluminum heat sink

FHF05 series has been calibrated using a well-conducting metal heat sink, representing a typical industrial application, at 20 °C and exposing it to a conductive heat flux. When used under conditions that differ from the calibration reference conditions, for example at extremely high or low temperatures, or exposed to radiative flux, the FHF05 series' sensitivity to heat flux may be different than stated on the certificate. In such cases, the user may choose:

- Not to use the sensitivity and only perform relative measurements/monitor changes.
- Reproduce the calibration conditions by mounting the sensor on, or between metal foils.
- Design a dedicated calibration experiment, for example using a foil heater which generates a known heat flux.
- Correct the sensitivity for the temperature dependence. See the appendix on correction of temperature dependence for more information.
- Apply our BLK black sticker to the sensor surface to absorb radiation.
- Apply our GLD gold sticker to the sensor surface to reflect radiation.

The user should analyze his own experiment and make his own uncertainty evaluation. The FHF05 series' rated temperature range for continuous use is -70 to +120 °C, for short intervals, peak temperatures -160 to +150 °C are allowed. Please contact Hukx when measuring at -160 °C, see also the appendix on use at low temperatures. Prolonged exposure to temperatures near +150 °C will accelerate the ageing process.

You may consider a single heat flux sensor as a sensor composed of several smaller heat flux sensors. In case users want to enlarge sensor surface area or sensitivity, consider putting multiple sensors electrically in series. See the chapter on electrical connection 5.3.

2.2 Measuring radiation and convection

At a surface, heat will often be transferred by a combination of radiation and convection. To accurately measure the convective part, the thermal resistance of the sensor should be as low as possible. For the radiative part, the optical surface properties of the sensor should be representative of the surrounding area.

Some points to keep in mind:

- Radiation is not only transmitted in the spectral range that humans can see (visible radiation) but also as non-visible far infrared.
- Blank metal is reflective in the visible as well as in the far infrared.
- Paints and plastic coatings, wood and stone absorb in different ranges, depending on their color in the visible range. These materials typically all behave as “black” in the far infrared.

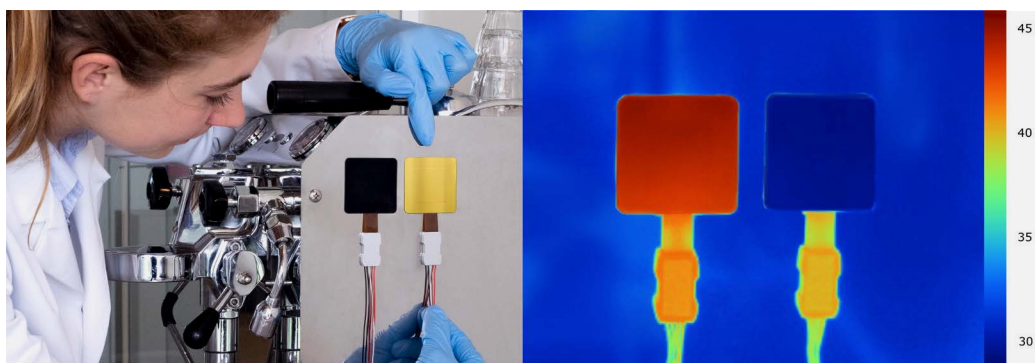

Figure 2.21 Application of a BLK black sticker and a GLD gold sticker on FHF models for measuring radiative and convective heat flux on an espresso machine. The machine has a polished metal surface of about 45 °C. The IR image on the right shows that the black sticker on the left, as well as the sensor wires and connector blocks, emit radiation. They appear in red on the image. The gold sticker and the metal surface have lower emission and appear as “bluish” in the image. Mounted on the same surface, the BLK and GLD stickers have the same temperature. The measurement with the sensor with the GLD sticker is most representative of the heat flux at the polished metal surface, while the sensor with the BLK sticker overestimates the heat flux.

2.3 Selecting a suitable FHF05 heat flux sensor model

FHF05 sensors are available in 5 different sizes. The following text helps you to select the right sensor for your application and the right electronics. Selecting the right electronics-sensor combination helps reduce total system costs.

Sensors with larger dimensions have a higher sensitivity and a larger area over which the heat flux is averaged and also a higher price.

2.3.1 Step 1—familiarize yourself with heat flux measurement

Visit the Hukx [YouTube](#) channel:

- [quick intro to heat flux](#) (3 min)
- [online course](#) (40 min)
- [separating radiation and convection](#) (2 min)

2.3.2 Step 2—verify if FHF05 sensors are suitable for your application and environment

- Check if the heat flux is between -10 to $+10 \times 10^3 \text{ W/m}^2$ (higher flux levels? See the appendix on use at different flux levels or model [FHF06](#)).
- Verify that the rated temperature range is below 120 °C.
- Verify other specifications chapter of this manual.

2.3.3 Step 3—verify what FHF05 model/size and optional BLK GLD stickers may be used

- Decide if you need a minimum sensor size.
- See which model fits in the available space.
- Check if you want to separate radiation and convection; if so, look at [BLK – GLD sticker series](#).

2.3.4 Step 4—look at electronics

Verify that your electronics are suitable:

- Estimate the output range of the heat flux sensor(s) in [$\times 10^{-6}$ V] using the sensitivities in the specifications table: microvolt output range = heat flux range in [W/m^2] \times sensitivity in [$\times 10^{-6}$ V/ (W/m^2)].
- Check if your electronics accept analogue voltage input.
- Check if the microvolt voltage measurement accuracy of your instruments is better than 1% of the output range, to ensure electronics are not the limiting factor in measurement accuracy. If your electronics accuracy is insufficient, you may choose a larger sensor or put sensors in series to create a higher sensitivity.
- Make sure that your electronics accept type T thermocouples. If not, consider whether a temperature measurement is needed or if a separate temperature sensor can be added.

2.3.5 Step 5—ask Hukx to check your choices

- Ask for our input/suggestions. Send all information and specifications of your application to Hukx. This includes: the purpose of the measurement, heat flux source, heat flux sink, expected heat flux and temperature ranges, electronic devices used, sketch of the setup indicating specifications and dimensions.
- Consider alternatives: the FHF sensors may not be the best option. We can supply many different sensor models optimized for a wide range of applications.

3 Specifications of FHF05 sensors

3.1 Specifications of sensors of the FHF05 series

The FHF05 series heat flux sensors measure the heat flux density through the sensor's surface. This quantity, expressed in W/m^2 , is called heat flux. Using a thermopile sensor, a FHF05 generates a small output voltage proportional to this flux. A Type T thermocouple is included for temperature measurement. No power supply is required. FHF05 sensors can only be used in combination with a suitable measurement system.

Table 3.1.1 Specifications of sensors of the FHF05 series (continued next pages).

FHF05 series specifications	
sensor type	foil heat flux sensor
sensor type according to ASTM	heat flow sensor or heat flux transducer
measurand	heat flux
measurand in SI units	heat flux density in W/m^2
measurement range	$(-10 \text{ to } +10) \times 10^3 \text{ W/m}^2$ at heat sink temperature $20 \text{ }^\circ\text{C}$ See appendix for detailed calculations.
sensitivity per dimension (nominal)	
FHF05-10X10	$1 \times 10^{-6} \text{ V/(W/m}^2\text{)}$
FHF05-15X30	$3 \times 10^{-6} \text{ V/(W/m}^2\text{)}$
FHF05-50X50	$13 \times 10^{-6} \text{ V/(W/m}^2\text{)}$
FHF05-15X85	$7 \times 10^{-6} \text{ V/(W/m}^2\text{)}$
FHF05-85X85	$50 \times 10^{-6} \text{ V/(W/m}^2\text{)}$
directional sensitivity	Heat flux from the backside to the frontside (side with the dot) generates a positive voltage output signal.
asymmetry	< 2%
increased sensitivity and spatial coverage	Multiple sensors may be put electrically in series. The resulting sensitivity is the sum of the sensitivities of the individual sensors. The resulting measurement is representative for the heat flux over the area covered by the sensors and may also be representative for the area between the sensors.

expected voltage output	$(-100 \text{ to } +100) \times 10^{-3} \text{ V}$ Turning the sensor over from one side to the other will lead to a reversal of the sensor voltage output.
measurement function/required programming	$\Phi = U/S$
required read-out	1 differential voltage channel or 1 single ended voltage channel, input resistance $> 10^6 \Omega$
optional read-out	1 temperature channel
rated load on wires	$\leq 1.6 \text{ kg}$
rated bending radius	$\geq 7.5 \times 10^{-3} \text{ m}$
rated temperature range, continuous use	-70 to +120 °C For use to -200 °C, see appendix.
rated temperature range, short intervals	120 to +150 °C
temperature dependence	$< 0.2 \text{ } \%/^{\circ}\text{C}$ See also the chapter on correction for temperature dependence.
non-linearity	$< 5 \text{ } \%$ (0 to $10 \times 10^3 \text{ W/m}^2$)
solar absorption coefficient	0.75 (indication only)
thermal conductivity dependence	negligible, $< 3 \text{ } \%/(\text{W/m}\cdot\text{K})$ for environments from 270 to 0.3 W/m·K
sensor thickness	$0.4 \times 10^{-3} \text{ m}$
sensor thermal resistance	$11 \times 10^{-4} \text{ K}/(\text{W/m}^2)$
sensor thermal conductivity	0.36 W/(m·K)
response time (95 %)	3 s
sensor length and width	
FHF05-10X10	(10 x 10) $\times 10^{-3} \text{ m}$
FHF05-15X30	(15 x 30) $\times 10^{-3} \text{ m}$
FHF05-50X50	(50 x 50) $\times 10^{-3} \text{ m}$
FHF05-15X85	(15 x 85) $\times 10^{-3} \text{ m}$
FHF05-85X85	(85 x 85) $\times 10^{-3} \text{ m}$

sensing area	
FHF05-10X10	0.64 x 10 ⁻⁴ m ²
FHF05-15X30	2.70 x 10 ⁻⁴ m ²
FHF05-50X50	12.96 x 10 ⁻⁴ m ²
FHF05-15X85	7.10 x 10 ⁻⁴ m ²
FHF05-85X85	49.70 x 10 ⁻⁴ m ²

sensing area length and width	
FHF05-10X10	(8 x 8) x 10 ⁻³ m
FHF05-15X30	(10 x 27) x 10 ⁻³ m
FHF05-50X50	(36 x 36) x 10 ⁻³ m
FHF05-15X85	(10 x 71) x 10 ⁻³ m
FHF05-85X85	(70 x 71) x 10 ⁻³ m

passive guard area	
FHF05-10X10	0.36 x 10 ⁻⁴ m ²
FHF05-15X30	2.25 x 10 ⁻⁴ m ²
FHF05-50X50	12.04 x 10 ⁻⁴ m ²
FHF05-15X85	5.65 x 10 ⁻⁴ m ²
FHF05-85X85	22.55 x 10 ⁻⁴ m ²

guard width to thickness ratio	
FHF05-10X10	2.5
FHF05-15X30	6.25
FHF05-50X50	17.5
FHF05-15X85	6.25
FHF05-85X85	18.75

sensor resistance range per dimension	
FHF05-10X10	5 to 30 Ω
FHF05-15X30	50 to 90 Ω
FHF05-50X50	200 to 300 Ω
FHF05-15X85	100 to 180 Ω
FHF05-85X85	800 to 1300 Ω

required sensor power	zero (passive sensor)
-----------------------	-----------------------

temperature sensor	type T thermocouple
--------------------	---------------------

temperature sensor accuracy	standard grade type T according to ASTM E230 (IEC 60584 Class 2) ± 1.0 °C or 0.0075 × T (whichever is greater) If the temperatures of the sensor foil and cable connection block are the same. See the appendix for other conditions.
-----------------------------	--

standard cable length	2 m
-----------------------	-----

optional cable length	0, 5 or 10 m
-----------------------	--------------

wiring	3 x copper and 1 x constantan wire, AWG 28, solid core, bundled with a PFA sheath
cable diameter	$2 \times 10^{-3} \text{ m}$
marking	Dot on foil indicating the front side of the heat flux sensor; 1 x label at the end of FHF05's cable, showing serial number and sensitivity.
IP protection class	IP67
rated operating relative humidity range	0 to 100 %
long-term exposure to water	See the appendix on long-term use under condensing, wet and underwater conditions.
rated operating pressure range	Sensor foil only: 8 bar uniform pressure. See the appendix on use under pressure. Sensor foil only: may be used in vacuum. See the appendix on use under vacuum.
gross weight including 2 m cable	approx. 0.5 kg
net weight including 2 m cable	approx. 0.5 kg
Installation and use	
typical conditions of use	In experiments, in measurements in laboratory and industrial environments. Exposed to heat fluxes for periods of several minutes to several years. Connected to user-supplied data acquisition equipment. Regular inspection of the sensor. Continuous monitoring of sensor temperature. No special requirements for immunity, emission, chemical resistance.
recommended number of sensors	2 or more per measurement location
installation	See the chapter on installation for recommendations.
bending	See the chapter on installation on curved surfaces.
cable extension	See the appendix on cable extension, or order sensors with longer cable length.
sensor foil installation	See the appendix on installation of FHF05 foils.

Calibration

calibration traceability	to SI units
product certificate	included (showing calibration result and traceability)
calibration method	method HFPC, according to ASTM C1130-21
calibration hierarchy	from SI through international standards and through an internal mathematical procedure
calibration uncertainty	$< \pm 5\%$ ($k = 2$)
recommended recalibration interval	2 years
calibration reference conditions	20 °C, heat flux of 300 (models -15X85 and -85X85) or 600 (models -10X10, -15X30 and -50X50) W/m ² , mounted on aluminum heat sink, thermal conductivity of the surrounding environment 0.0 W/(m·K)
validity of calibration	<p>Based on experience the instrument sensitivity will not change during storage. During use the instrument "non-stability" specification is applicable.</p> <p>When used under conditions that differ from the calibration reference conditions, the FHF05 sensitivity to heat flux may be different than stated on its certificate. See the chapter on instrument principle for suggested solutions.</p>
field validation	<p>Is possible by comparison to a calibration reference sensor. Usually mounted side by side, alternative on top of the field sensor. Preferably reference and field sensor of the same model and brand.</p> <p>Typical duration of test > 24 h.</p> <p>See the paragraph on validation and calibration.</p>

Measurement accuracy

uncertainty of the measurement

Statements about the overall measurement uncertainty can only be made on an individual basis.

Versions/options

with longer cable length

option code = cable length in meters

without cable, without connection block

calibrated FHF05 sensor foil
To be soldered/connected by the user.
See appendix for more information.

with black sticker applied

BLK sticker applied to the sensor at the factory to absorb radiation.

with gold sticker applied

GLD sticker applied to the sensor at the factory to reflect radiation.

Accessories

hand-held read-out unit

L119 handheld read-out unit/data logger
NOTE: L119 does not measure temperature, only heat flux

separate foil heater

HTR02 general-purpose heater, that can be used for test and calibration purposes.

separate cable

cable with 3 x copper and 1 x constantan wire, AWG 28, solid core, bundled with an PFA sheath available in 2, 5 or 10 m length

separate black stickers

BLK sticker to absorb radiation, to be applied by the user.

separate gold sticker

GLD sticker to reflect radiation, to be applied by the user.

3.2 Dimensions of FHF05 series

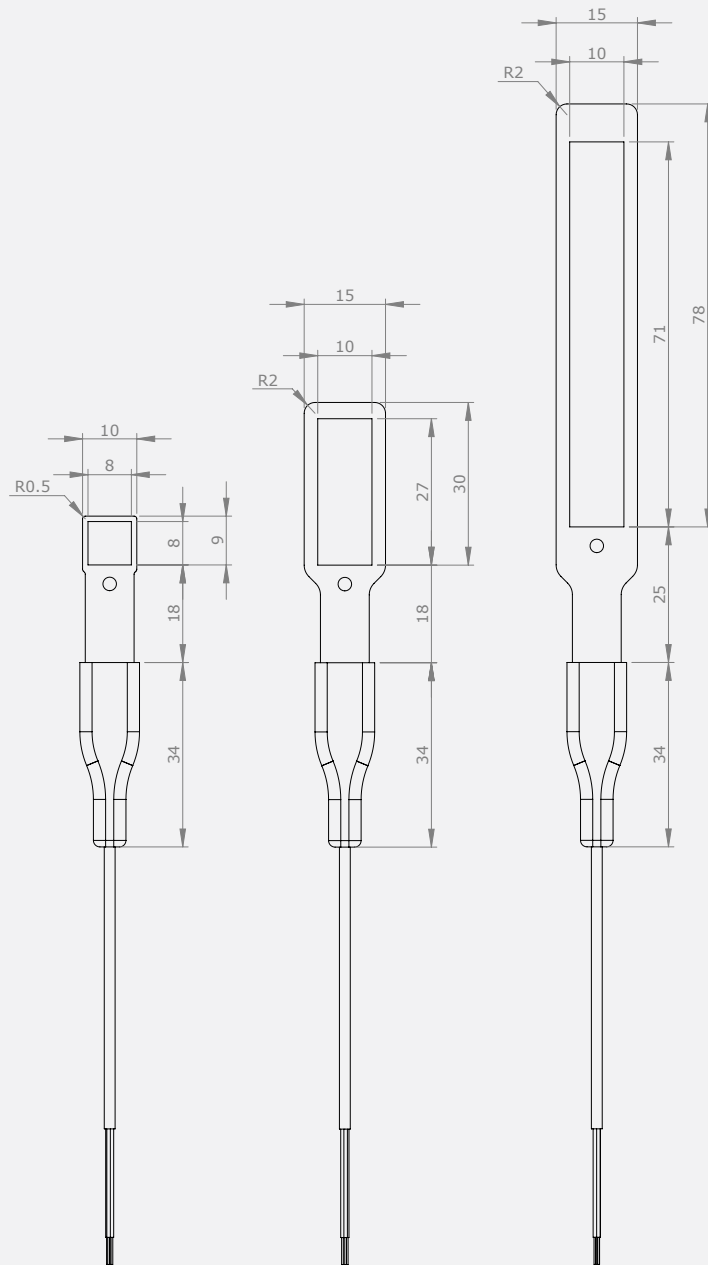

Figure 3.2.1 Models FHF05-10X10, -15X30, and -15X85; with dimensions in $\times 10^{-3}$ m.

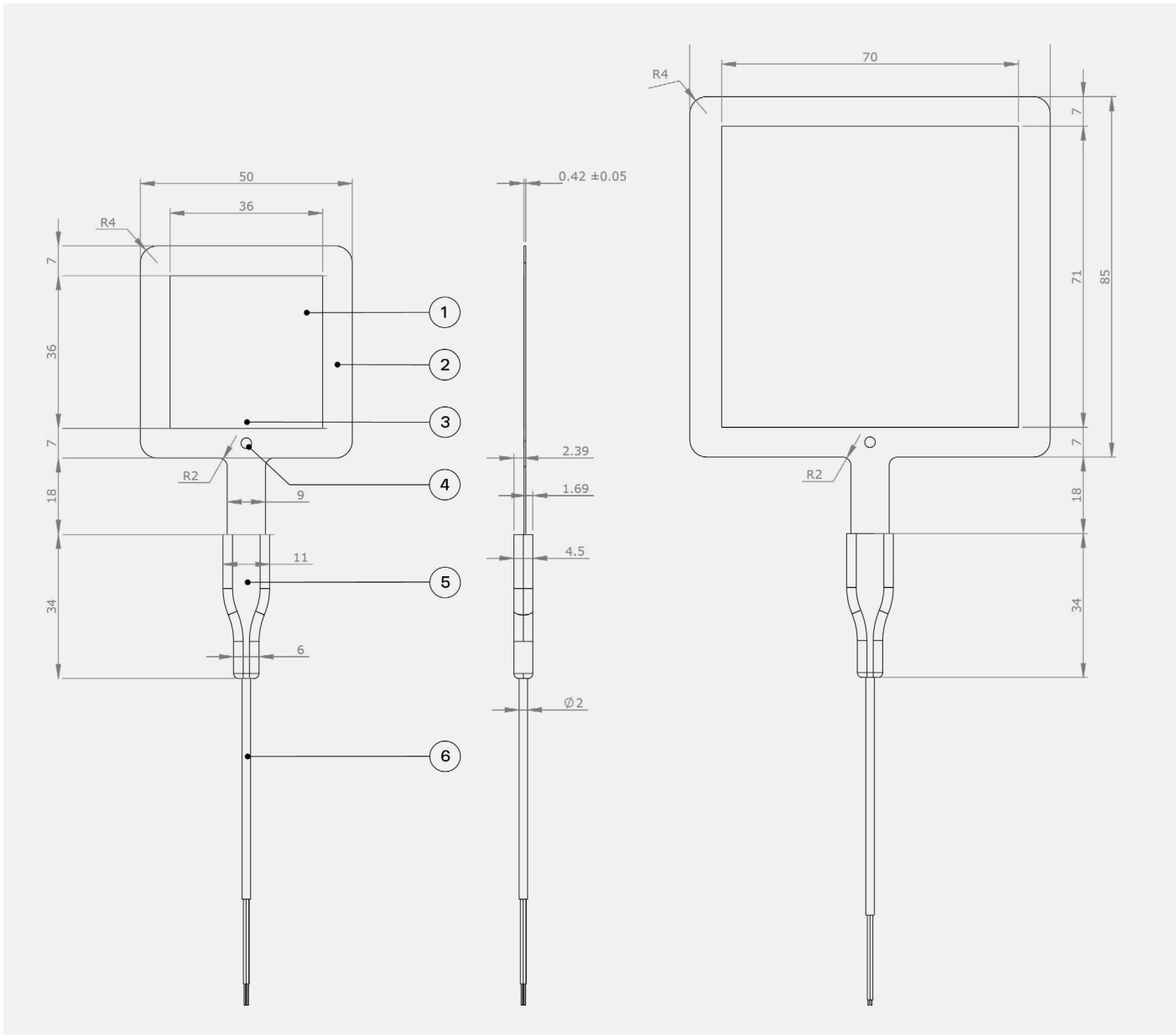

Figure 3.2.2 Models FHF05-50X50, -85X85; with dimensions in $\times 10^{-3}$ m.

1. sensing area with thermal spreaders
2. passive guard
3. type T thermocouple
4. dot indicating frontside
5. potted cable connection block for strain relief
6. cable, standard length $C = 2$ m

4 Standards and recommended practices for use

FHF05 sensors should be used in accordance with recommended practices.

There are no ISO, ASTM or IEC standards with recommended practices for use of heat flux sensors like FHF05.

4.1 Heat flux measurement in industry

FHF05 sensors are often used to measure on industrial walls and metal surfaces, estimating the installation's energy balance and the thermal transmission of walls. Typically, the total measuring system consists of multiple heat flux and temperature sensors. In many cases, heat flux sensors are used for trend monitoring. In such cases, reproducibility is more important than absolute measurement accuracy.

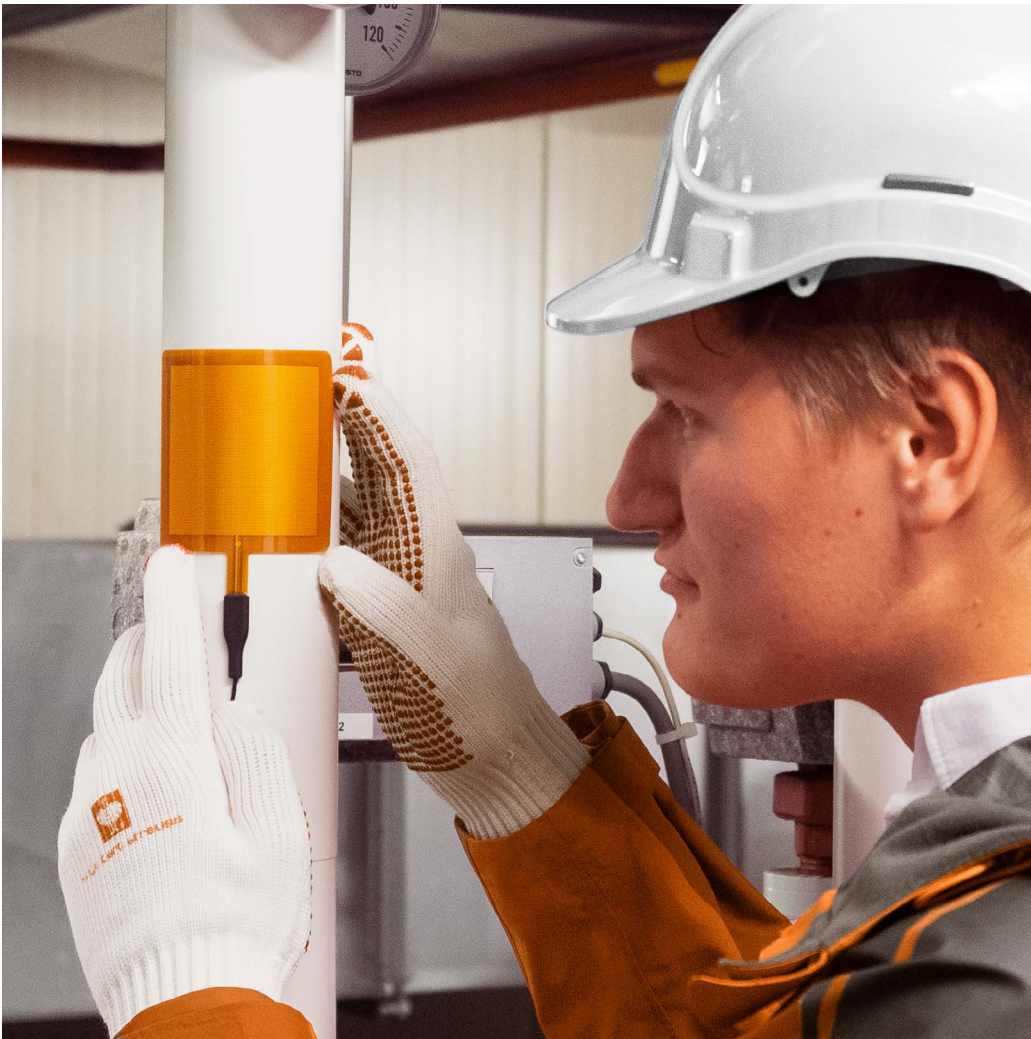

Figure 4.11 Example of model FHF05-85X85 foil heat flux sensor being installed for measurement on an industrial pipe. The sensor is mounted on a well-prepared curved surface.

5 Installation of FHF05 sensors

Before performing a measurement and permanently installing a heat flux sensor, we recommend extensively testing the sensor and the entire measuring system.

For example,

- Confirm the functionality and measurement accuracy of the temperature sensor in a temperature bath.
- Confirm the functionality and accuracy of the heat flux measurement in a separate experiment, for example using electrical heaters such as those of the HTR series and a heatsink.

In such experiments, you may select a temperature and a heat flux sensor to serve as references and determine deviations relative to this reference.

5.1 Why to avoid air gaps

The thermal conductivity of air is in the order of $0.02 \text{ W/(m}\cdot\text{K)}$. Therefore, even small air gaps are significant thermal resistances. The thermal conductivity of plastic or thermal paste is in the order of $0.2 \text{ W/(m}\cdot\text{K)}$, so for the same thickness, thermal resistance is a factor 10 lower. Take for example a $0.05 \times 10^{-3} \text{ m}$, air gap. This has a thermal resistance of $20 \times 10^{-4} \text{ K/(W/m}^2\text{)}$. This may be compared to around $10 \times 10^{-4} \text{ K/(W/m}^2\text{)}$ for FHF sensors, so a small air gap produces an increase of thermal resistance of respectively 200 % for FHF. Using a filler of $0.05 \times 10^{-3} \text{ m}$, with a thermal conductivity around 10 times higher than that of air, the thermal resistance is reduced to $2.5 \times 10^{-4} \text{ K/(W/m}^2\text{)}$. The contribution of the thermal resistance reduces to about 20 %.

This example also shows that high-thermal conductivity tapes are not necessary. Using a thin normal tape is enough.

An air gap may not only lead to a higher thermal resistance for conductive heat, but also to an entirely different radiation balance. An air gap is a "resistance" (a radiation screen) for radiative transfer. If it is filled-up, it is no resistance any longer. Watch out in case radiative (far infrared) heat flux is significant. In that case, the presence of an air gap may be the dominant source of errors, because a sensor with an air gap acts as a radiation shield, reducing local radiative transfer by a theoretical maximum of 50 %.

5.2 Site selection and installation

See also our application note on [how to install a heat flux sensor](#).

Table 5.2.1 Recommendations for installation of FHF05 series heat flux sensors (continued on next page).

location	Choose a location that is representative of the process that is analyzed if possible, avoid exposure to sun, rain, etc. do not expose to drafts and lateral heat fluxes do not mount in the vicinity of thermal bridges, cracks, heating or cooling devices and fans.
performing a representative measurement/ recommended number of sensors	We recommend using > 2 sensors per measurement location. This redundancy also improves the assessment of the measurement accuracy.
mounting	<p>When mounting a FHF05, keep the directional sensitivity in mind; heat flux from the backside to the frontside (side with dot) generates a positive voltage output signal.</p> <p>To achieve the highest accuracy temperature measurement, fix the cable connection block to the object of interest, so that the temperature of the connection block remains as close as possible to that of the heat flux sensor (see appendix on accuracy of the temperature measurement).</p>
surface cleaning and leveling	Create a clean and smooth surface of at least the outer dimensions of the sensor in use.
mechanical mounting: avoiding strain on the sensor to cable transition	During installation as well as operation, the user should provide proper strain relief on the cable so that the cable connection block is not exposed to significant force first, install the sensor by providing strain relief on the connection block and after that install the cable including additional strain relief.
short-term installation	<p>To avoid air gaps, we recommend thermal paste or glycerol for short-term installation.</p> <p>Use tape to mount the sensor on the surface. If possible, tape only over the passive guard area (surrounding the sensing area). See Figure 5.2.1</p> <p>Use tape to mount the cable connection block of the sensor.</p> <p>Usually, the cables are mounted with an additional strain relief, for example using a cable tie mount as in Figure 5.2.1</p>

permanent installation

For long-term installation, fill up the space between sensor and object with silicone construction sealant, silicone glue or silicone adhesive that can be bought at construction depots.

We discourage the use of thermal paste for permanent installation because it tends to dry out. Silicone glue is more stable and reliable.

signal amplification

See the paragraph on electrical connection.

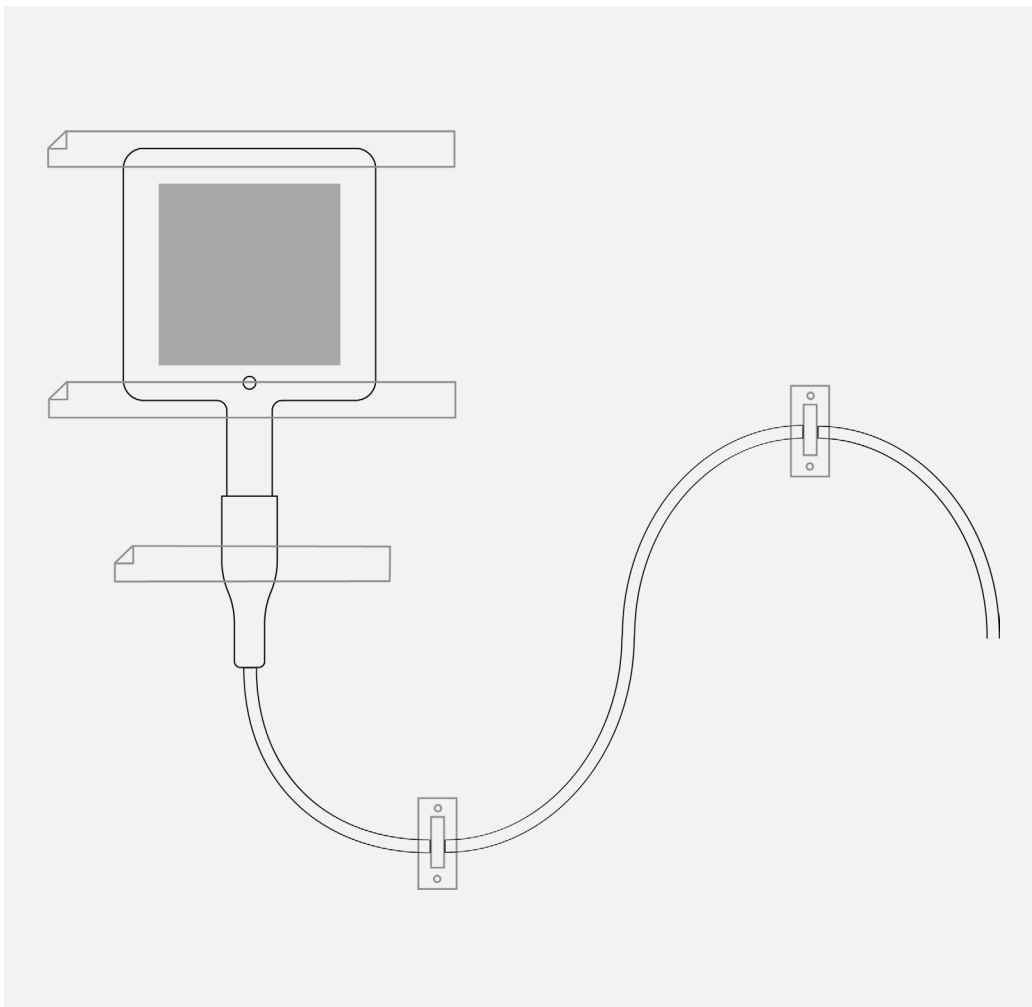

Figure 5.21 Installation of model FHF05-50X50 using tape to fix the sensor and the connection block. Extra strain relief on the cable is provided using cable tie mounts equipped with double-sided tape as an adhesive. As indicated in Table 5.11, tapes used for mounting the sensor are preferably taped over the passive guard area and not on the sensing area (the latter indicated by grey shading in Figure 5.1.1). Please note the dot is visible in this image; this indicates that we are viewing the frontside and that the other side, the backside, is attached to the object on which the sensor is mounted, as in Figure 2.2.

Table 5.2.2 Options for mounting heat flux sensors. Materials may act to position the sensor, but also to fill up airgaps.

product	duration	temperature range	functionality	comments
[type]	[time]	[°C]	[description]	[description]
single sided tape	temporary or permanent	-260 to 150	positioning and gap filling	Positioning only, use with other fillers such as thermal paste TESA 51408 orange masking tape most commercially available Kapton tapes are suitable.
silicone glue	permanent potentially removable	-45 to 200	positioning and gap filling	Most commercially available silicone glues are suitable DOWSIL 3145 silicone sealant Before silicone hardens the sensor is typically held in position using a tape.
high temperature epoxies	permanent not removable	to 300	positioning and gap filling	Duralco 4460 adhesive epoxy.
glycerine	short term	to 120	gap filling only	Filler only for quick experiments; glycerine can be obtained at the local pharmacy. It is safe to use and easily dissolves in water.
toothpaste	short-term (days)	40	gap filling only	Filler only, use with other positioning such as single-sided tape water-based most commercially available toothpastes are suitable.
thermal paste	weeks	to 177	gap filling only	Filler only, use with other positioning such as single-sided tape silicone oil-based DOW CORNING heat sink compound 340.

5.3 Installation on curved surfaces

The flexibility of FHF05 sensor foils makes them perfectly suitable for installation on singly curved surfaces. The sensor foil can be bent around any axis.



Figure 5.3.1 Bending of model FHF05-50X50 foil heat flux sensor, in this image on a pipe.

When measuring on curved surfaces, the same recommendations of the previous chapter apply, except that the use of thermal paste is recommended over glycerol. For installation on curved surfaces, it is usually not achievable to tape only over the passive guard area. Use sufficient tape to make sure the sensor remains fixed and in good thermal contact with curved surface. Avoid air gaps. Tape can be used over the sensing area when necessary.

Table 5.3.1 Extra recommendations for installation of FHF05 series foil heat flux sensors on curved surfaces.

bending	sensor foil can be bent in all directions
rated bending radius	$\geq 7.5 \times 10^{-3} \text{ m}$
effect on sensitivity	no significant influence on sensitivity

5.4 Electrical connection

5.4.1 Electrical diagram

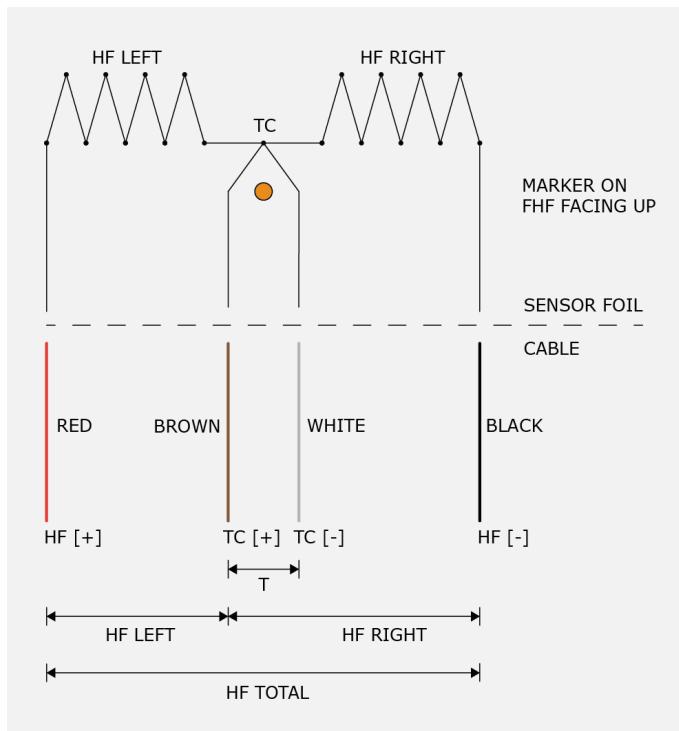

Figure 5.4.11 Electrical diagram of sensor foil and cable of FHF sensors.

5.4.2 Normal connection

A heat flux sensor should be connected to a measurement system, typically a so-called data logger. FHF05's heat flux and temperature sensors are passive and do not need any power. Cables and wires may act as a source of distortion, by picking up capacitive noise. We recommend keeping the distance between a data logger or amplifier and the sensor as short as possible. For cable extension, see the appendix on this subject.

Table 5.4.2.1 The electrical connection of FHF05.

wire		measurement system
red	heat flux signal [+]	voltage input [+]
black	heat flux signal [-]	voltage input [-]
brown	thermocouple type T [+]	thermocouple input [+]
white	thermocouple type T [-]	thermocouple input [-]

The sensor serial number and sensitivity are shown on the FHF05's product certificate and at the end of FHF05's cable.

NOTICE

Putting more than 24 Volt across the sensor wiring can lead to permanent damage to the sensor.

NOTICE

The heat flux sensor and thermocouple are electrically connected inside the FHF sensor foil. In the hardware used for measurement of the sensor output, do not electrically short-circuit (part of) the heat flux signal and thermocouple; this will reduce signal output by 50 %.

5.4.3 Increasing sensitivity and spatial coverage—connecting multiple sensors in series

Multiple heat flux sensors may be electrically connected in series. By making a connection, the resulting output becomes the sum of the output of the individual sensors. The sensitivity then is the sum of the sensitivities of the individual sensors. The resulting measurement is then representative of the heat flux over the area covered by the sensors and may also be representative for the area between the sensors.

Below are the equations in case two sensors are used. If needed, more than two sensors may be put in series, again increasing the sensitivity.

$$\Phi = U/(S_1 + S_2) \quad (\text{Formula 5.4.3.1})$$

and

$$U = U_1 + U_2 \quad (\text{Formula 5.4.3.2})$$

Table 5.4.3.1 The electrical connection of two FHF05 sensors, 1 and 2, in series. In such case the sensitivity is the sum of the two sensitivities of the individual sensors. More sensors may be added in a similar manner.

sensor	wire		measurement system
1	red	signal 1 [+]	voltage input [+]
1	black	signal 1 [-]	connect to signal 2 [+]
1	brown	thermocouple type T [+]	
1	white	thermocouple type T [-]	
2	red	signal 2 [+]	connect to signal 1 [-]
2	black	signal 2 [-]	voltage input [-] or ground
2	brown	thermocouple type T [+]	
2	white	thermocouple type T [-]	

The serial number and sensitivity of the individual sensors are shown on the FHF05 sensor's product certificate and at the end of FHF05's cable.

For the temperature measurement, users may consider

- To read out one thermocouple only.
- To put several thermocouples in parallel (so feeding several thermocouple wires to one input channel). The temperature reading will then be the weighted average of the signals. Weighting is by $1/R$ with R the electrical resistance. In case cables are equally long, with the same conductor diameters, this will result in a normal average.

5.4.4 Connection to read out half signals

See Figure 5.3.4.1: heat flux sensors in FHF05 series can be connected to read out only the heat flux through the left half of the sensing area or the heat flux through the right half of the sensing area. This feature may be used for quality assurance purposes; if the sensor is correctly installed, a constant percentage (usually close to 50 %) of the signal will be generated by the left and right. If the two 50 % signals are read out, the sensor's brown wire is typically connected to a thermocouple input, and from there, two copper wires may be used to connect the same signal to the two 50 % heat flux millivolt read-out inputs.

NOTE: in case the user works with voltage measurements in which the [-] is connected to ground, use the 100 % and "right" 50 % signals only, and do not use the "left" configuration. These then share the same ground as the heat flux sensor [-]. Connecting the "left" as well, would create a short-circuit over the right signal, so that only the left signal is measured.

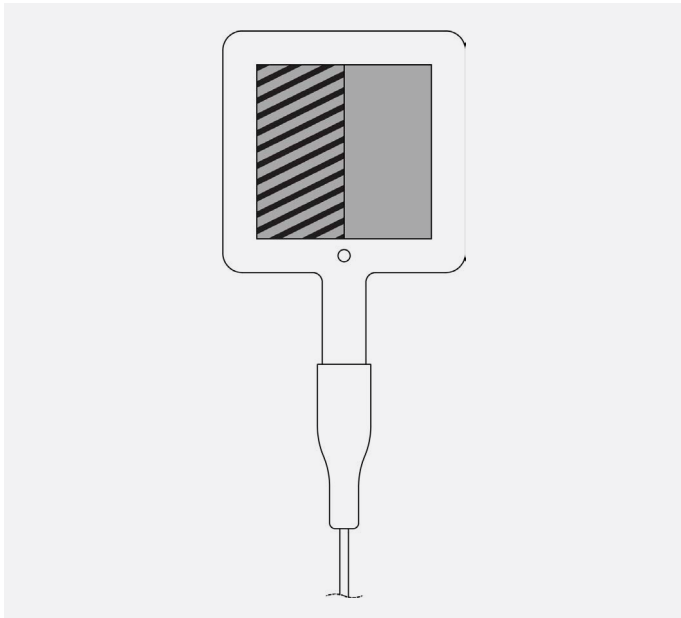

Figure 5.4.4.1 Model FHF05-50X50 with left half indicated by diagonal lines.

Table 5.4.4.1 The electrical connection of FHF05 for 100 % signal.

wire		measurement system
red	heat flux signal [+]	voltage input [+]
black	heat flux signal [-]	voltage input [-] or ground
brown	thermocouple type T [+]	
white	thermocouple type T [-]	

Table 5.4.4.2 The electrical connection of FHF05 for left 50 % signal.

wire		measurement system
red	heat flux signal [+]	voltage input [+]
black	heat flux signal [-]	
brown	thermocouple type T [+]	voltage input [-] or ground
white	thermocouple type T [-]	

Table 5.4.4.3 The electrical connection of FHF05 for right 50 % signal.

wire		measurement system
red	heat flux signal [+]	
black	heat flux signal [-]	voltage input [-] or ground
brown	thermocouple type T [+]	voltage input [+]
white	thermocouple type T [-]	

5.5 Requirements for data acquisition/amplification

The selection and programming of data loggers is the responsibility of the user. Please contact the supplier of the data acquisition and amplification equipment to see if directions for use with FHF05 sensors are available. In case a program for similar sensors is available, this can be used. All FHF05's can be treated in the same way as other heat flux sensors and (analogue) thermopile pyranometers.

NOTICE

Do not use "open circuit detection" when measuring the heat flux sensor and thermocouple output signals.

Table 5.5.1 Requirements for data acquisition and amplification equipment for FHF05 sensors in the standard configuration.

capability to measure small voltage signals	<p>preferably: $< 5 \times 10^{-6}$ V uncertainty minimum requirement: 20×10^{-6} V uncertainty (valid for the entire expected temperature range of the acquisition/amplification equipment)</p> <p>Select your data logger voltage range setting carefully, based on the heat flux sensor sensitivity and the expected heat flux level. Setting your data logger voltage range too high may lead to a low resolution and large offsets, not allowing you to detect changes at low heat flux levels. Setting your data logger voltage range too low may lead to overranging, leading to a cap in measured heat flux level or temperature, or leading to data logger measurement errors.</p>
capability for the data logger or the software	To store data, and to perform division by the sensitivity to calculate the heat flux. $\Phi = U/S$
capability to measure thermocouple type T	preferably: ± 3 °C uncertainty
data acquisition input resistance	$> 1 \times 10^6 \Omega$
open circuit detection (WARNING)	<p>Open circuit detection should not be used, unless this is done separately from the normal measurement by more than 5 times the sensor response time and with a small current only. Thermopile sensors are sensitive to the current that is used during open circuit detection. The current will generate heat, which is measured and will appear as a temporary offset.</p>

6 Maintenance and trouble shooting

6.1 Recommended maintenance and quality assurance

FHF05 measures reliably at a low level of maintenance. Unreliable measurement results are detected by scientific judgement, for example by looking for unreasonably large or small measured values. The preferred way to obtain a reliable measurement is a regular critical review of the measured data, preferably checking against other measurements.

Table 6.1.1 Recommended maintenance of FHF05 sensors. If possible, the data analysis is done daily.

Minimum recommended heat flux sensor maintenance			
	interval	subject	action
1	1 week	data analysis	<p>Compare measured data to the maximum possible or maximum expected heat flux and to other measurements for example from redundant instruments.</p> <p>Look for any patterns and events that deviate from what is normal or expected.</p> <p>Set acceptance intervals for temperature and heat flux and compare measured data to these acceptance intervals.</p>
2	6 months	inspection	<p>Inspect sensor for wear, cable and wire condition, clamping of conductors at the data acquisition, inspect sensor mounting, inspect location of installation.</p> <p>Look for repeating (day–night, seasonal) patterns in measurement data.</p> <p>Try to explain these patterns.</p>
3	2 years	validation and recalibration	<p>Validation by comparison to a calibration reference sensor in the field, see the following paragraph about validation and calibration.</p> <p>Recalibration by the sensor manufacturer.</p>
4	2 years	lifetime assessment	<p>Judge if the instrument will be reliable for another 2 years, or if it should be replaced.</p>

6.2 Trouble shooting

Table 6.2.1 Trouble shooting for FHF sensors (continued on the next page).

<p>general</p>	<p>Inspect the sensor for any damage. Inspect the quality of mounting/installation. Inspect if the wires are properly attached to the data logger.</p> <p>Check the condition of the cable and wires.</p> <p>Check the data logger program, in particular if the right sensitivity is entered. FHF sensor sensitivity and serial number are shown on the product certificate and at the end of the FHF's cable.</p> <p>Check the electrical resistance of the sensor between all wires. In many cases, this can be done on the screws of the clamps of the signal wires. In other cases, it is necessary to disconnect signal wires from the data acquisition.</p> <p>See the following tables for the nominal electrical resistances per wire combination.</p> <p>Measure resistances first with one polarity, then reverse the polarity. Actual resistance values may vary from one sensor to the other sensor and with cable length. The typical resistance of the copper wiring (red, brown and black wires) is 0.3 Ω/m, for the constantan wiring (white wire) this is 6.5 Ω/m. Infinite resistance indicates a broken circuit; zero or a lower than 1 Ω resistance indicates a short circuit.</p>
<p>The heat flux sensor does not give any signal.</p>	<p>Check if the sensor reacts to heat: put the multimeter at its most sensitive range of DC voltage measurement, typically the 100 x 10⁻³ VDC range or lower. Expose the sensor to heat. Exposing the backside (the side without the dot) to heat should generate a positive signal between the red [+] and black [-] wires, doing the same at the frontside (the side with dot), the sign of the output reverses.</p> <p>Check the data acquisition by replacing the sensor with a spare unit.</p>

The heat flux sensor signal is unrealistically high or low.

Check the wire condition.

Ensure that the wires clamp on the metal conductor and not (partly) on the plastic cladding of the wires.

Disconnect heat flux signal wires from data acquisition.

Check the data acquisition by applying a 1×10^{-6} V source to it in the 1×10^{-6} V range. Look at the measurement result. Check if it is as expected.

Check the data acquisition by short circuiting the data acquisition input with a 10Ω resistor. Look at the output. Check if the output is close to 0 W/m^2 . Check the data logger voltage range settings.

- A voltage range setting that is too high lead to a low signal resolution and high offsets.

- A voltage range setting that is too low can cause the sensor signal to cap at a maximum level of generate data logger errors.

Check for possible interference between the heat flux signal and thermocouple output. The heat flux signal and thermocouple are electrically connected inside the heat flux sensor. An electrical short-circuit between (part of) the heat flux signal and thermocouple, which may occur if they are both grounded, can reduce heat flux signal output by 50 %.

- With the thermocouple wires connected, disconnect the heat flux signal wires from the data acquisition and observe the behavior of the thermocouple reading.

- With the heat signal wires connected, disconnect the thermocouple signal wires and observe the behavior of the heat flux signal.

- Make sure the thermocouple measurement and heat flux/voltage measurements have no open circuit detection. If this is activated, disable it.

The heat flux or temperature sensor signal shows unexpected variations.

Check the presence of strong sources of electromagnetic radiation (radar, radio).

Check the condition of the sensor wires.

Check if the wires are not moving during the measurement.

If available on your data logger, turn on 50 Hz or 60 Hz noise filtering.

Ground your data logger.

The temperature measurement shows unrealistic values.

Check if the thermocouple type T is selected in the data logger program.

Check if a correct reference temperature is selected in the program.

Check the electrical resistance of the thermocouple between the brown [+] and white [-] wires. Use a multimeter at the 100 Ω range. Measure the thermocouple resistance first with one polarity, then reverse the polarity. Take the average value. The typical resistance of the copper wiring is 0.3 Ω /m, for the constantan wiring this is 6.5 Ω /m. Typical resistance should be the nominal thermocouple resistance of 2.5 Ω plus 6.8 Ω for the total resistance of the two wires of each meter (back and forth). Infinite resistance indicates a broken circuit; zero or a lower than 1 Ω resistance indicates a short circuit.

Make sure the temperature of the connection block remains as close as possible to that of the heat flux sensor. See appendix on temperature measurement accuracy for more information.

Check the program settings, signal range settings and sampling speed of your data logger. Please ask the data logger provider to comment on the data files.

Do not use open circuit detection on your data logger. In FHF05 sensors the thermocouple is electrically connected to the heat flux sensor. Some older data loggers do not properly handle such electrical connection. Disconnect the heat flux signal wires from the data acquisition to see if this is the cause of the problem. Check the connection of the thermocouple wires to the data logger. Ensure that the wires clamp on the metal conductor and not (partly) on the plastic cladding of the wires.

Do not ground the thermocouple [-]. Only heat flux [-] should be connected to ground if needed. If the [-] minus signals of both the heat flux and the temperature are connected to ground, the heat flux sensor is partly, 50 %, short-circuited and the signal will be reduced by around 50 %.

Make sure that the sensor does not pick up electrical noise by external sources (e.g., heavy machinery like heaters or air conditioners blowing hot or cold air over the sensor).

Table 6.2.2 Indicative electrical resistances between wires for FHF05-10X10 with standard cable length.

	red	black	brown	white
red	x	15 Ω	10 Ω	25 Ω
black		x	10 Ω	25 Ω
brown			x	15 Ω
white				x

Table 6.2.3 Indicative electrical resistances between wires for FHF05-15X30 with standard cable length.

	red	black	brown	white
red	x	70 Ω	35 Ω	50 Ω
black		x	35 Ω	50 Ω
brown			x	15 Ω
white				x

Table 6.2.4 Indicative electrical resistances between wires for FHF05-15X85 with standard cable length.

	red	black	brown	white
red	x	160 Ω	80 Ω	95 Ω
black		x	80 Ω	95 Ω
brown			x	15 Ω
white				x

Table 6.2.5 Indicative electrical resistances between wires for FHF05-50X50 with standard cable length.

	red	black	brown	white
red	x	280 Ω	140 Ω	155 Ω
black		x	140 Ω	155 Ω
brown			x	15 Ω
white				x

Table 6.2.6 Indicative electrical resistances between wires for FHF05-85X85 with standard cable length.

	red	black	brown	white
red	x	1100 Ω	550 Ω	565 Ω
black		x	550 Ω	565 Ω
brown			x	15 Ω
white				x

6.3 Validation and calibration

The recommended calibration interval of heat flux sensors is 2 years. Recalibration of field heat flux sensors is ideally done by the sensor manufacturer.

On-site field validation—that is, making sure the sensor is fit for purpose—is possible by comparison to a calibration reference sensor, which is usually mounted side by side or alternatively on top of the field sensor.

Hukx's main recommendations for field validations are:

1. To compare to a calibration reference of the same brand and type as the field sensor.
2. To connect both to the same electronics so that electronics errors (also offsets) are eliminated.
3. To mount all sensors on the same platform, so that they have the same body temperature.
4. Typical duration of test: > 24 h
5. Typical heat fluxes used for comparison: > 200 W/m²
6. To correct deviations of more than $\pm 20\%$. Lower deviations should be interpreted as acceptable and should not lead to a revised sensitivity.

Users may also design their own validation or calibration experiment, for example using a well-characterized foil heater.

7 Appendices

7.1 Appendix on cable and cable extension

FHF05 sensors are equipped with one cable containing four wires. Three copper wires (red, brown and black) and one constantan wire (white). Standard cable length is 2 m. It is possible to order FHF05 series with longer cable lengths or without any cable. A separate cable is available in 2, 5 or 10 m length.

Cables and wires may act as a source of distortion by picking up capacitive noise. Keep the distance between data logger or amplifier and sensor as short as possible.

In an electrically "quiet" environment, the FHF05 series cable may be extended without problems. If done properly, the sensor signal, although small, will not significantly degrade because the sensor electrical resistance is very low (which results in good immunity to external sources) and because the voltage measurement circuit of the data logger has a high impedance. There is no current flowing, and there are no resistive losses.

Cable, wire and connection specifications are summarized below.

Table 7.1.1 Preferred specifications for cable and wire extension of FHF05 series.

cable and wiring	<p>Extend the red, brown and black wire with copper wires. Extend the white wire with constantan wire.</p> <p>For the constantan wire, use the right alloy for type T thermocouple measurements: $Cu_{55}Ni_{45}$</p> <p>For constantan and copper, use either Standard grade type T according to ASTM E230 or IEC 60584 Class 2. Use of thermocouple extension cables is permitted, because for type T these have nominally the same composition as thermocouple cables.</p> <p>Standard cable as supplied by Hukx: 3 x copper and 1 x constantan wire, AWG 28, solid core, bundled with an PFA sheath.</p>
separate cable	<p>Available in 2, 5 or 10 m length longer cables may be offered as a "special" order.</p>
extension sealing	<p>Make sure any connections are sealed against humidity ingress.</p>
conductor resistance	<p>< 0.3 Ω/m (copper wire)</p>
cable outer diameter	<p>2×10^{-3} m</p>
length	<p>Cables and wires should be kept as short as possible, in any case, the total cable length should be less than 100 m.</p>
connection	<p>Either use gold-plated waterproof connectors, or solder the conductors and shield of the extension cables to those of the original sensor cable, and make a waterproof connection using heat-shrink tubing with hot-melt adhesive.</p> <p>When using connectors for extending the thermocouple wires, either use dedicated type T thermocouple connectors, or use connectors with a heavy metal housing in which no temperature differences occur, or put the connection in an enclosure in which no temperature differences occur.</p>

7.2 Appendix on installation of FHF05 sensor foils

FHF05 sensors can optionally be ordered without cable and without cable connection block. It is also possible to order cables as separate parts.

The user should ensure a good connection to the sensor by either soldering wires or alternatively, using a FFC / FPC ZIF connector. See Table 7.2.1 and 7.2.2 for recommendations.

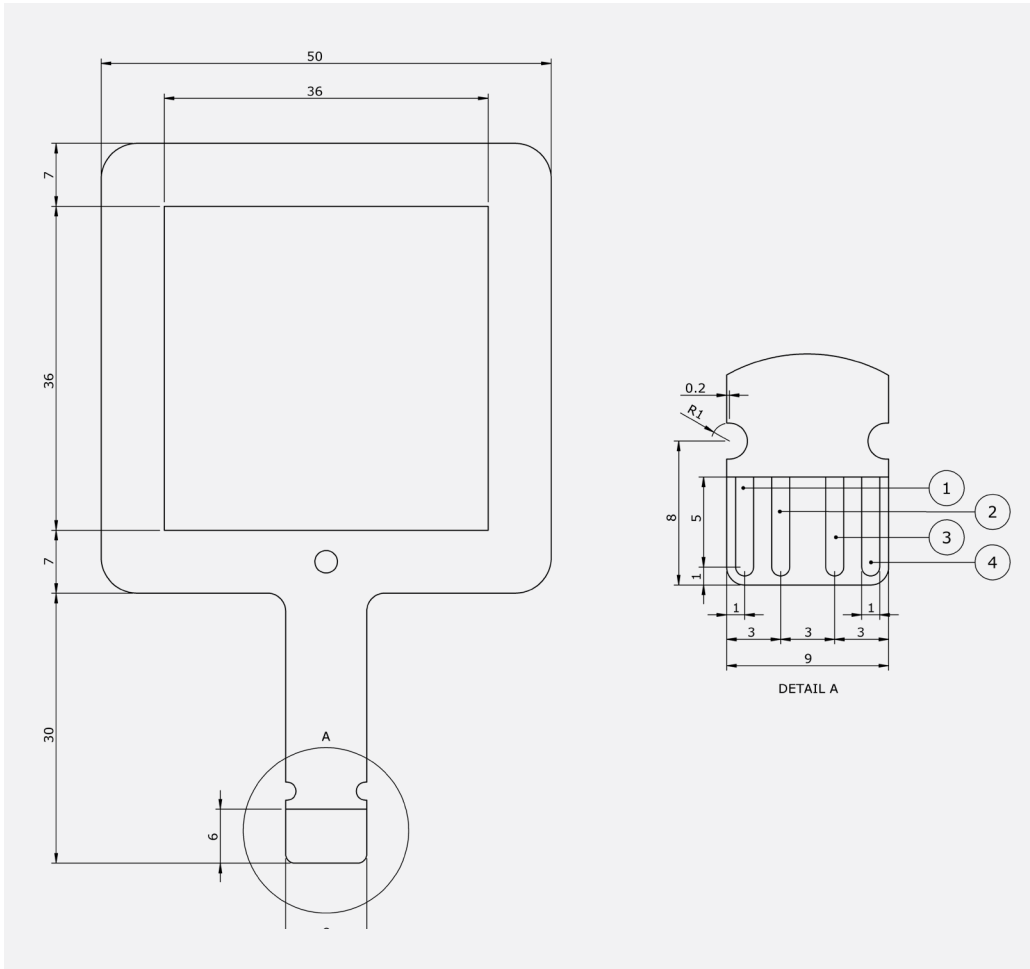

Figure 7.2.1 FHF05-50X50 sensor foil; detail A is the same for all FHF's; dimensions in $\times 10^{-3}$ m. The dimensions of the tab are identical for all FHF sensor models.

1. heat flux signal [+], copper
2. thermocouple type T [+], copper
3. thermocouple type T [-], constantan ($\text{Cu}_{55}\text{Ni}_{45}$)
4. heat flux signal [-], copper

Table 7.2.1 Recommendations for soldering FHF05 series sensor foils.

wire	Use insulated wires of preferably at least AWG28 it is possible to order a separate cable. Figure 7.2.1 shows which wire type to connect to which pad.
preparation	Clean soldering pad before soldering with isopropyl alcohol (IPA).
solder material	Preferably use lead-free solder.
soldering temperature	Use a soldering temperature of max 350 °C.
contact time	As short as possible (± 2 seconds).
surface	Place sensor with soldering pad on a well-insulated surface.
strain relief	Add strain relief on the solder connections, for example by potting the connection with epox.

NOTICE

Accidentally cross-connecting the wires with soldering material will short-circuit part of the sensor. The voltage output of heat flux sensor may go to 50 % of the full heat flux or to 0. The temperature sensor output may go to zero, and then measure panel temperature only.

NOTICE

Avoid long contact between sensor foil and soldering equipment.
Excess heat can damage the soldering contacts.

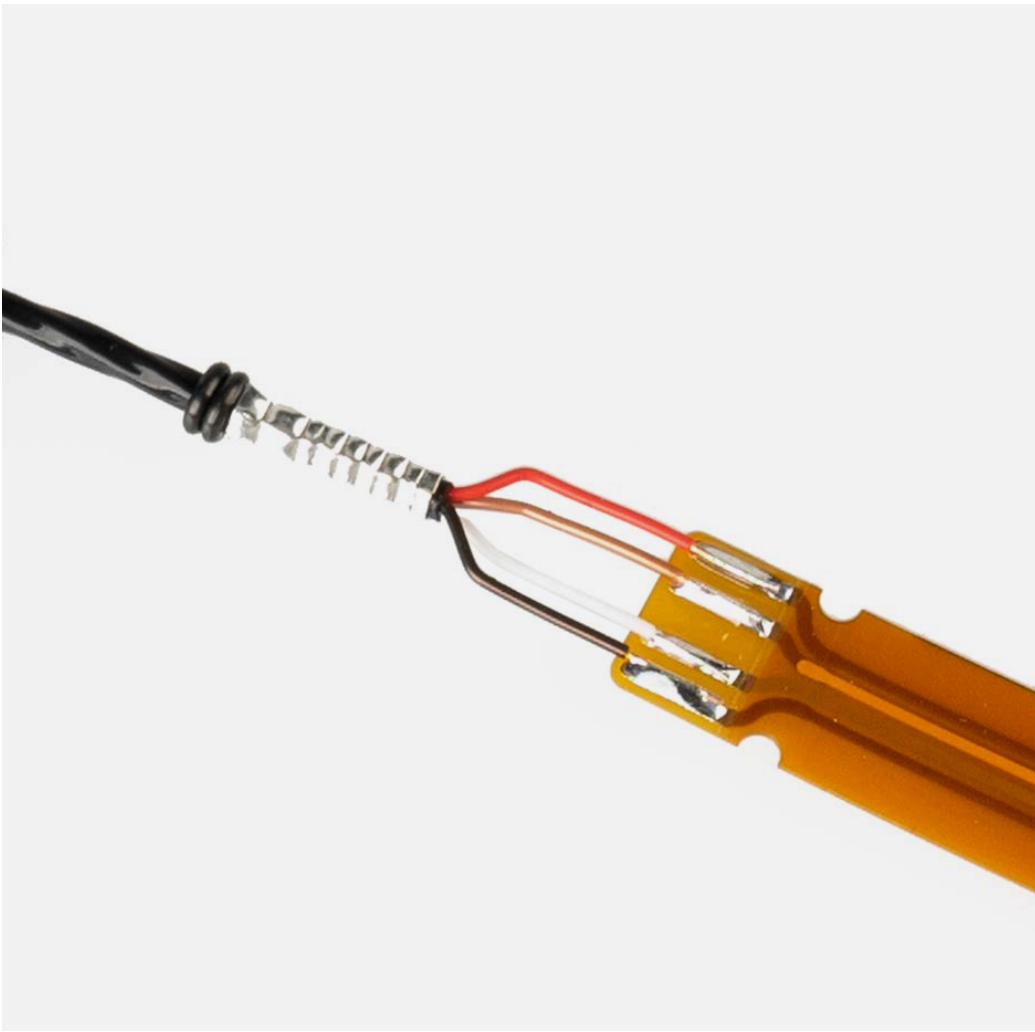

Figure 7.2.2 FHF05 series sensor foil with soldered wires.

Table 7.2.2 Recommendations for ZIF connectors for FHF05 series sensor foils.

connector type	FFC / FPC (Flat Flex Cable / Flexible Printed Circuit)
connector variant	ZIF (Zero Insertion Force)
number of contacts	8 contacts, where only position 1, 3, 6 and 8 are used
pitch	$1 \times 10^{-3} \text{ m}$
external environment	Use FHF05 sensor foils with ZIF connector only in a dry and stable environment.

7.3 Appendix on using FHF05 sensors with BLK – GLD sticker series

BLK black and GLD gold stickers are accessories for the heat flux sensors of the FHF05 series and FHF05SC series. A sensor equipped with a BLK black sticker is sensitive to both radiative and convective heat flux. A sensor equipped with a GLD gold sticker reflects radiation and measures convective heat flux only. To calculate the radiative heat flux, subtract the two measurements.

There are BLK – GLD stickers for every sensor model in FHF05 series.

BLK – GLD stickers are designed to be applied by the user. Optionally, it is also possible to order FHF05 with stickers pre-applied at the factory.

For more details, see the BLK – GLD sticker series user manual.

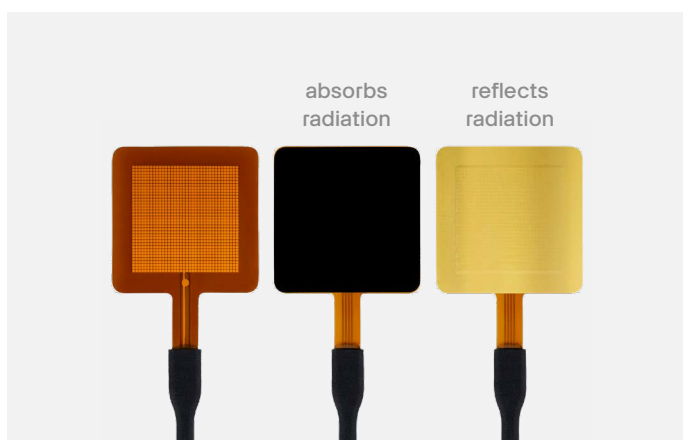

Figure 7.3.1 FHF05-50X50 heat flux sensor: with BLK-50X50 and GLD-50X50 stickers.

Table 7.3.1 Recommendations for use of FHF05 heat flux sensors with BLK – GLD stickers.

mounting	When mounting a BLK or GLD sticker on an FHF05 sensor, keep the directional sensitivity in mind. Heat flux from the backside to the frontside (side with dot) generates a positive voltage output signal.
mounting on curved surfaces	Apply BLK – GLD stickers before mounting the sensor.
location	Avoid direct exposure to the sun.
effect on sensitivity	BLK – GLD stickers have no significant influence on sensitivity.

7.4 Appendix on standards for calibration

The standard ASTM C1130-21 *Standard Practice for Calibrating Thin Heat Flux Transducers* specifies in Chapter 6 that a guarded hot plate, a heat flowmeter, a hot box or a thin heater apparatus are all allowed. Hukx employs a thin heater apparatus, uses a linear function according to X1.1 and uses a nominal temperature of 20 °C, in accordance with X2.2.

The Hukx HFPC method relies on a thin heater apparatus according to principles as described in paragraph 4 of ASTM C1114-06, used in the single-sided mode of operation described in Paragraph 8.2 and in ASTM C1044-16.

ISO does not have a dedicated standard practice for heat flux sensor calibration. We follow the recommended practice of ASTM C1130-21.

Table 7.4.1 Heat flux sensor calibration according to ISO and ASTM.

Standards on instrument classification and calibration

ISO standard

No dedicated heat flux calibration standard available.

Equivalent ASTM standard

ASTM C1130-21 Standard Practice for Calibrating Thin Heat Flux Transducers

ASTM C 1114-06 Standard Test Method for Steady-State Thermal Transmission Properties by Means of the Thin-Heater Apparatus

ASTM C1044-16 Standard Practice for Using a Guarded-Hot-Plate Apparatus or Thin-Heater Apparatus in the Single-Sided Mode

7.5 Appendix on calibration hierarchy

FHF05's factory calibration is traceable from SI through international standards and through an internal mathematical procedure that corrects for known errors. The formal traceability of the generated heat flux is through voltage and current to electrical power and electric power and through length to surface area.

The Hukx HFPC method follows the recommended practice of ASTM C1130-21. It relies on a thin heater apparatus according to principles as described in Paragraph 4 of ASTM C1114-06, in the single-sided mode of operation described in Paragraph 8.2 and in ASTM C1044-16. The method has been validated in a first-party conformity assessment, by comparison to calibrations in a guarded hot plate.

7.6 Appendix on correction for temperature dependence

The sensitivity of an FHF05 sensor depends on the temperature of the sensor. The temperature dependence of FHF05 series is specified as $< 0.2\%/^{\circ}\text{C}$.

The calibration reference temperature is $20\text{ }^{\circ}\text{C}$.

Users who measure at temperatures that deviate much from $20\text{ }^{\circ}\text{C}$ or who measure over a wide range of temperatures may wish to correct for this temperature dependence.

To correct for the temperature dependence of the sensitivity, use the following measurement function

$$\Phi = U/(S \cdot (1 + 0.002 \cdot (T - 20))) \quad (\text{Formula 7.6.1})$$

with Φ the heat flux in W/m^2 , U the FHF05 series voltage output in V, S the sensitivity in $\text{V}/(\text{W}/\text{m}^2)$ at $20\text{ }^{\circ}\text{C}$ and T the FHF05 temperature. The coefficient of 0.002 or 0.2 [%/K] is the best estimate Hukx currently has of the temperature dependence of sensitivity.

S is shown on the product certificate and at the end of FHF05's cable.

7.7 Appendix on measurement range for different temperatures

The measurement range of FHF05 sensors is specified as $(-10 \text{ to } +10) \times 10^3 \text{ W/m}^2$ at $20 \text{ }^\circ\text{C}$ heat sink temperature. This is a very conservative specification.

In reality, the rated temperature for continuous use of $+120 \text{ }^\circ\text{C}$ is the limiting specification. The sensor temperature T in $^\circ\text{C}$ in a specific application depends on the heatsink temperature T_{heatsink} in $^\circ\text{C}$, the heat flux Φ in W/m^2 and the thermal resistance per unit area $R_{\text{thermal,A}}$ of the sensor in $\text{K}/(\text{W/m}^2)$.

$$T = T_{\text{heatsink}} + \Phi \cdot R_{\text{thermal,A}} \quad (\text{Formula 7.7.1})$$

This means the measurement range is lower for higher heat sink temperatures.

$$\Phi_{\text{maximum}} = (120 - T_{\text{heatsink}}) / R_{\text{thermal,A}} \quad (\text{Formula 7.7.2})$$

Table 7.7.1 shows measurement ranges for different heat sink temperatures. For applications where the sensor is not mounted on a heatsink, use the ambient temperature instead of the heatsink temperature.

NOTE: The calculated values are based on the sensor's thermal resistance only. We assume that the thermal resistance of any glue layer is negligible.

Table 7.7.1 Measurement range for different heat sink temperatures.

heatsink temperature (in $^\circ\text{C}$)	measurement range
20 $^\circ\text{C}$	$91 \times 10^3 \text{ W/m}^2$
40 $^\circ\text{C}$	$73 \times 10^3 \text{ W/m}^2$
60 $^\circ\text{C}$	$55 \times 10^3 \text{ W/m}^2$
80 $^\circ\text{C}$	$36 \times 10^3 \text{ W/m}^2$
100 $^\circ\text{C}$	$18 \times 10^3 \text{ W/m}^2$

7.8 Appendix on temperature measurement accuracy

All FHF's have an integrated thermocouple to measure the temperature of the object under test. This thermocouple then performs a separate secondary measurement, in addition to the main heat flux measurement.

The uncertainty of the temperature measurement is the sum of the thermocouple measurement uncertainty (a sensor property) + the voltage measurement uncertainty of the electronics + the reference junction measurement uncertainty. The reference junction uncertainty and the uncertainty of the electronics should be part of the specifications of electronics. Please note the latter two are often ignored, because their contributions are typically small.

The FHF sensors are equipped with a cable containing thermocouple extension wires with an uncertainty specified as a type T thermocouple, IEC 60584-1:2013 class 2 or ASTM. They consist of a brown positive copper (Cu) wire and a negative white constantan ($\text{Cu}_{55}\text{Ni}_{45}$) wire. The contribution of thermocouple properties to the measurement uncertainty is $1\text{ }^\circ\text{C}$ or $\pm 0.75\%$ (whichever is larger) of the temperature differences between the cold joint T_2 and the sensor cold junction T_3 (see Figure 7.8.1).

For most applications, we may assume that the cold junction uncertainty is negligible and that the temperatures T_1 and T_2 are identical.

The total expanded measurement uncertainty becomes, as stated in the specifications:

$$u_c(T) = (1\text{ }^\circ\text{C or } \pm 0.75\% \cdot \Delta T_2) \quad (\text{Formula 7.8.1})$$

However, if you want more detail: in the FHF sensor itself, the thermocouple junction (T_1) located at the object under test consists of copper and constantan traces that are extended from the connection block to the edge of the heat flux sensor sensitive area. These traces have slightly different Seebeck coefficients compared to normal thermocouple materials, which results in a higher measurement uncertainty of $\pm 5\%$ for temperature differences between T_1 and T_2 junctions.

The total expanded measurement uncertainty becomes:

$$u_c(T) = \text{cold junction uncertainty} + 5\% \cdot \Delta T_1 + (1\text{ }^\circ\text{C or } \pm 0.75\% \cdot \Delta T_2) \quad (\text{Formula 7.8.2})$$

It is clear from Formula 7.8.2 that the accuracy is best, i.e., within the 2% range, if T_1 is kept close to the temperature T_2 so that $\Delta T_1 = 0$. If the temperature measurement is critical, consider using a separate more accurate temperature sensor.

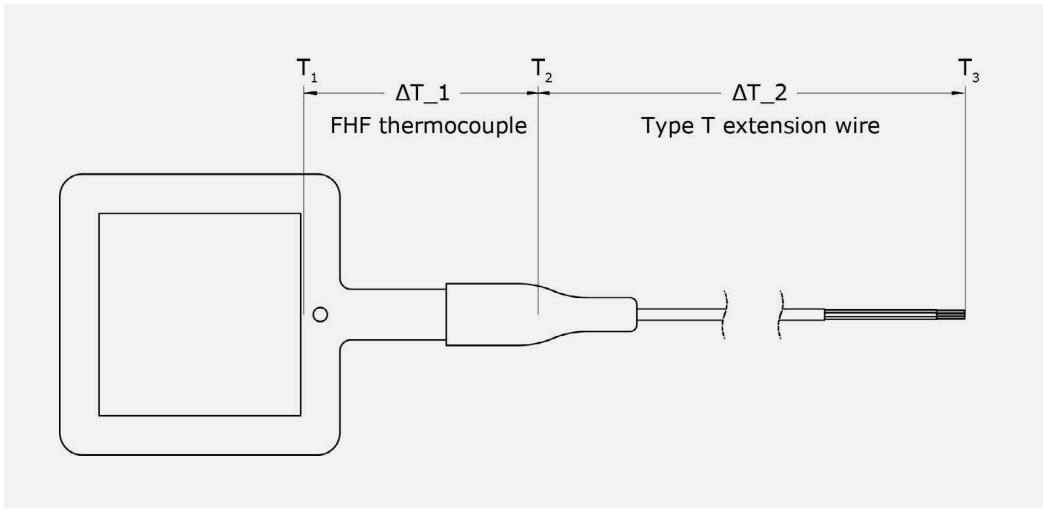

Figure 7.8.1 Model FHF05-50x50 with its thermocouple junctions. To minimize temperature measurement uncertainty, please make sure that ΔT_1 is close to zero.

7.9 Appendix on use of FHF sensor foils at low temperatures to $-200\text{ }^\circ\text{C}$

FHF users have employed the FHF05, FHF05SC and FHF06 sensor foils in cryogenic conditions, below the rated temperature of $-70\text{ }^\circ\text{C}$. Although the use at lower temperatures is possible, Hukx does not specify the use down to $-200\text{ }^\circ\text{C}$ formally because the application of any sensors, not just these, at such temperatures is always high-risk. Use at a temperature lower than $-70\text{ }^\circ\text{C}$ is at the user's own risk.

NOTICE

At temperatures lower than the rated $-70\text{ }^\circ\text{C}$ FHF05, FHF05SC and FHF06 sensor foils may become stiffer and more brittle than in the rated temperature range. Use of these foils at these temperatures is possible, but at the user's own risk.

Practical experience at temperatures $< -70\text{ }^\circ\text{C}$:

- Hukx tested the FHF05 sensor foils at $-80\text{ }^\circ\text{C}$ and found no issues.
- FHF05 sensor foils have been used in liquid natural gas ($-160\text{ }^\circ\text{C}$) conditions without problems.

Directions for use at temperatures < -70 °C:

- Use the sensor foil only, not the cable connection block.
- The cable connection block between foil and cable is potted and not rated for lower temperatures than -70 °C. At lower temperatures use the sensor foil only, not the cable connection block.
- The FHF sensor foils are made using Kapton etched foil technology. The materials used are Kapton (polyimide), acrylic glue (not for FHF06) plus the metals of the sensor. This technology is generally considered suitable for use down to -200 °C.
- At temperatures below -70 °C the sensor foil of FHF will become rigid and brittle. It is important not to change the sensor position at low temperatures because it will likely break the sensor. At low temperatures the FHF sensor foil loses its flexibility but besides this, the sensors work just as normal.
- Users may order the standard FHF cable as a separate item. This is made of PFA; its temperature rating is -200 to +260 °C.
- Users may solder signal wires to the foil by themselves following the directions in the manual of the sensor. If needed, seal the soldered connections using suitable potting material.
- If you expect small signals and want to know if a sensor still functions or if you want to monitor the stability, you can use the FHF05SC sensors. The heater materials are the same as the foil sensor. Soldering is also similar. The -SC version is available only for certain FHF05 sensor sizes.
- The sensitivity of the FHF sensors at low temperatures may become very low. Temperature dependence is around $< 0.2\% / ^\circ\text{C}$. So, at -200 °C, you have 64 % of the sensitivity left compared to the calibration reference situation at room temperature. Users may correct for temperature dependence of the sensitivity with the approximation of the manual of the sensor. This uses a temperature dependence of the sensitivity of $+ 0.2\% / ^\circ\text{C}$. If needed, for higher accuracy, Hukx can determine the sensitivity from -30 to +50 °C, which users can then extrapolate to the temperature of their application. This is an additional service available at extra cost.
- Use of optional BLK black stickers is limited to -40 °C. However please note that in the infrared, the normal Kapton sensor surface behaves as a black emitter and absorber, so you may not need a black sticker.
- Use of the optional GLD gold stickers is limited to -185 °C.

7.10 Appendix on use of FHF sensor foils under vacuum conditions

FHF users have successfully employed the FHF05, FHF05SC and FHF06 sensor foils under vacuum conditions. Hukx does not specify the use under vacuum conditions, because the application of any sensors, not just these, under vacuum is always high-risk. Use under vacuum conditions is possible, but at the user's own risk.

NOTICE

Use of FHF05, FHF05SC and FHF06 sensor foils under vacuum conditions is possible, but at the user's own risk.

Directions for use under vacuum:

- Use the sensor foil only, not the cable connection block.
- The cable connection block between foil and cable is potted with an epoxy. The epoxy may outgas under vacuum. The sensor foils do not outgas.
- The FHF sensor foils are made using Kapton etched foil technology. The materials used are Kapton (polyimide), acrylic glue (not for FHF06) plus the metals of the sensor. This technology is generally considered suitable for use under vacuum. The outgassing is specified for the FHF06 foil.
- Under vacuum the sensors work just as normal.
- Users may order the standard FHF cable as a separate item. This is made of PFA which is formally rated for use under vacuum
- Users may solder signal wires to the foil by themselves following the directions in the sensor manual. If needed, seal the soldered connections using suitable potting material.
- Model FHF06 sensor foil has a formal outgassing specification (low outgassing, 0.36 % total mass loss, 0.01 % collected volatile condensable material (CVCM) as per NASA-JSC).

7.11 Appendix on long-term use in condensing, wet, and underwater conditions

FHF users have employed the FHF05, FHF05SC and FHF06 sensors in condensing, wet and underwater conditions, also for periods of many years and at high water pressure. However, Hukx formally specifies such use under IP67 for short—30 minutes—duration and at a limited pressure—0.5 m of water—only. Long-term application under wet conditions is possible, but always high-risk and at the user's own risk.

Examples of successful application are:

- Buried in the soil, exposed to rainwater.
- In a high-pressure water vessel as part of a simulated service test for deep-sea pipelines (sensor foil only, not the cable connection block and not the sensor cable). In most cases, users make their own connection to the sensor foil.
- Mounted on the wall of a house, frequently exposed to rainwater.

NOTICE

Use of FHF05, FHF05SC and FHF06 sensors under wet conditions beyond IP67 (0.5 m depth and 30 minutes exposure) is possible, but at the user's own risk.

Directions for use under wet conditions are:

- The sensor foil materials and the materials of the potted cable connection block can absorb a limited amount of water only. However, as a result of exposure to this absorbed water over a long term the alloys in the sensor foil and conductors in the cable may slowly corrode. Corrosion may result in loss of sensitivity. Corrosion may be noticed by measuring changes in electrical resistance, because corrosion leads to increase of the electrical resistance.
- The sensor cable is not waterproof. It is open at the cable end. Operating in wet conditions, in case of damage to the cable and/or wire cladding the conductors may be directly exposed to water. In most cases, exposure to water has no effect; electrical resistance of water tends to be high. However, in case water conducts, for example, if it contains salts, this may lead to ground loops or loss of signal.
- Users should perform regular inspections of the sensor and the cable condition.
- Users may solder signal wires to the sensor foil by themselves following the directions in the sensor manual. In case of exposure to water, seal the soldered connections using suitable potting material.

7.12 Appendix on use of FHF sensor foils under pressure

Hukx specifies the use of FHF05 sensor foils to 8 bar uniform pressure. For model FHF06 this specification is 25 bar uniform pressure. This pressure may result from air or fluids under pressure or be mechanical pressure in case the sensor is clamped.

NOTICE

Use of FHF05, FHF05SC sensor foils above 8 bar pressure and FHF06 sensor foils above 25 bar pressure is possible, but at the user's own risk.

During the manufacturing process of our FHF05 sensors, an 8 bar pressure is used for the lamination process on the foil. So, the rated operating condition of 8 bar specification is safe. Previous, very similar heat flux sensors were manufactured at 40 bars. Thus, Hukx has reasonable confidence in the performance of the foils up to 40 bar, but any use above 8 bar is at the user's own risk.

The FHF06 sensor is manufactured under much higher pressure levels and does not contain acrylic glue layers. It is much stiffer and can be used up to 25 bar.

Directions for use under pressure:

- The pressure specification applies to the sensor foil only, not the cable and not the cable connection block.
- The pressure specification applies to uniform pressure only; avoid exercising mechanical pressure at one point on the foil.
- Users may solder a signal wires to the sensor foil by themselves following the directions in the sensor manual. In case of exposure to water, seal the soldered connections using suitable potting material.

7.13 EU declaration of conformity

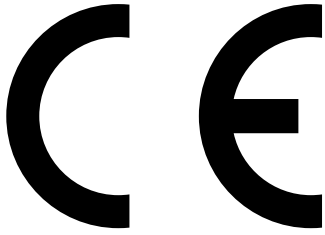

We, **Hukseflux Thermal Sensors B.V.**,
Delftechpark 31, 2628 XI, Delft,
The Netherlands

hereby declare under our sole responsibility that:

Product models	FHF05 series, all models
Product type	Heat flux sensors
Brand name	Hukx

conform with the following directive(s):

2011/65/EU, EU 2015/863	The Restriction of Hazardous Substances Directive
-------------------------	---

This conformity is declared using the relevant sections and requirements of the following standards,

Hazardous substances	EU RoHS2 (2011/65/EU) and EU 2015/863 amendment known as RoHS 3
----------------------	--

Eric HOEKSEMA
Director
Delft, 22 May 2024

About Hukx

Hukx is the leading innovator in solar radiation and heat flux sensor technology. We are proud to set the standard in high-accuracy measurement, and to be working at the heart of the energy transition.

Customers worldwide rely on our bestselling pyranometers and heat flux sensors. From sensor design and selection to supply and recalibration, we support you across the entire lifecycle.

Hukx is headquartered in the Netherlands, with locally owned representative sales offices in the USA, Brazil, India, China, Southeast Asia, and Japan.

Let us help you select the best sensor for your application. Get in touch with our experts today via: info@hukx.com

© Hukx

Version 2511

We reserve the right to change specifications without prior notice.

www.hukx.com

HUKX