

HUKX

Sensor
Technology

User manual
Industrial diffusometer

SRD100-D1

Cautionary statements

Cautionary statements are subdivided into four categories: danger, warning, caution and notice according to the severity of the risk.

DANGER

Failure to comply with a danger statement will lead to death or serious physical injuries.

WARNING

Failure to comply with a warning statement may lead to risk of death or serious physical injuries.

CAUTION

Failure to comply with a caution statement may lead to risk of minor or moderate physical injuries.

NOTICE

Failure to comply with a notice may lead to damage to equipment or may compromise reliable operation of the instrument.

Contents

Introduction	6
1 Ordering and checking at delivery	13
1.1 Ordering the SRD100-D1	13
1.2 Included items	13
1.3 Quick instrument check	14
2 Instrument principle and theory	15
2.1 Diffuse solar radiation	15
2.2 Instrument principle	16
3 Specifications	18
3.1 General overview	18
3.2 Rated operating conditions	19
3.3 Diffusometer specifications	21
3.4 Electrical specifications	22
3.5 Environmental	26
3.6 Weight and dimensions	27
3.7 Optional accessories	29
3.8 Measurands, certificates and calibration	30
4 Standards and recommended practices for use	34
4.1 Classification standards	34
4.2 General rules for solar radiation measurement	34
4.3 Specific use in meteorology and climatology	35
4.4 Specific use for PV system performance testing	36
4.5 General use for sunshine duration measurement	37
4.6 Using pyranometer data to improve measurement accuracy	38
4.7 Reducing environmental impact	38
4.8 Reducing total cost of ownership	39
5 Installation	40
5.1 Site selection	40
5.2 Configuring the instrument	41
5.3 Mechanical installation of the instrument	42
5.4 Electrical installation design	48
5.5 Electrical connections	56
5.6 Setting up Modbus RTU communication	57
5.7 Programming, register structure	58
6 Instrument diagnostics	59
6.1 Instrument temperature	60
6.2 Internal relative humidity	61
6.3 Internal heating	62
7 Maintenance and trouble shooting	63
7.1 Recommended maintenance and quality assurance	63
7.2 Trouble shooting	65
7.3 Calibration and validation	67
7.4 Spare parts	68
7.5 Repair services	68
7.6 Scratches on domes; optical surface imperfections	69

8 Appendices	71
8.1 Appendix on standards for classification and calibration	71
8.2 Appendix on calibration hierarchy	71
8.3 Appendix on expected change of the WRR scale	73
8.4 Appendix on meteorological radiation quantities	74
8.5 Appendix on the definition of diffusometer specifications	75
8.6 Appendix on terminology/glossary	76
8.7 Appendix on sensor performance	78
8.8 Appendix on sensor performance	80
8.9 EU declaration of conformity	82

List of symbols

quantities	symbol	unit
relative humidity	RH	%
irradiance	E	W/m ²
subscripts		
heater power	heater	
reference	reference	
acronyms		
AM	airmass	
ASTM	American Society for Testing and Materials	
AWG	American Wire Gauge	
BSRN	Baseline Surface Radiation Network	
DHI	Diffuse Horizontal Irradiance	
DNI	Direct Normal Irradiance	
EA	European co-operation for Accreditation	
EIA-485	Electronic Industries Alliance	
EMC	Electromagnetic Compatibility	
GHI	Global Horizontal Irradiance	
GUM	Guides to the expression of uncertainty in measurement	
IEC	International Electrotechnical Commission	
IPC	International Pyrheliometer Comparisons	
ISO	International Organization for Standardization	
LPZ	Lightning Protection Zone	
NPC	NREL Pyrheliometer Comparisons	
POA	Plane of Array irradiance	
POAREAR	Rearside Plane of Array irradiance	
PV	Photovoltaic	
RHI	Reflected Horizontal Irradiance	
RS-485	Recommend Standard	
RTU	Remote Terminal Unit	
SPD	Surge Protection Device	
SCADA	Supervisory Control And Data Acquisition	
UV	Ultra Violet	
WMO	World Meteorological Organization	
WRR	World Radiometric Reference	
WSG	World Standard Group	

Modbus® is a registered trademark of Schneider Electric, licensed to the Modbus Organization, Inc.

Introduction

The new SRD100-D1 industrial diffusometer is designed to accurately measure diffuse irradiance. When combined with a pyranometer like the SR300-D1, users can separate the direct and diffuse components of solar radiation. SRD100-D1 will typically be part of an IEC 61724-1 Class A PV performance monitoring system.

- no moving parts: utilizes a static sensor array and unique shadow mask with a Fibonacci lattice
- industry-leading accuracy: fully-compliant with IEC61724-1 requirements for Class A monitoring systems
- digital connectivity: includes remote diagnostics and supports MODBUS communication over an RS-485 interface
- built-in heating: provides dew and frost mitigation for reliable operation in all climates
- optimized for PV: delivers high-accuracy measurements, specifically designed for clear-sky and partly cloudy conditions that are most relevant for PV applications
- can be used as spectrally matched reference device measuring the PV-usable portion of solar radiation
- rugged surge protection: integrated industrial-grade surge protection ensures durability under extreme PV power plant conditions, with an optional SPD01 Surge Protection Device available to upgrade to 4 kV
- global support network: backed by our worldwide service organization for the lowest total cost of ownership

Figure 01 Industrial diffusometer model SRD100-D1.



SRD100-D1: industrial-grade diffuse solar radiation measurement

Hukx introduces the SRD100 diffusometer, an advanced, all-digital, heated sensor engineered for reliable and accurate measurement of diffuse solar radiation. When paired with a pyranometer, the SRD100 provides a complete picture of solar irradiance, including both the direct and diffuse components for high-accuracy PV performance monitoring.

The SRD100 diffusometer is a new instrument, tailored for use in PV monitoring systems, but is also well-suited for other applications such as general meteorological monitoring and building physics.

The diffusometer complies with Industrial-grade Immunity, Emission, Electrical, Environmental, and Safety requirements for demanding outdoor and industrial conditions, greatly improving measurement reliability. The SRD100's extended functionality and diagnostics further enhance ease of operation.

How it works: diffuse solar radiation

The SRD100 diffusometer features a sensor array and half-sphere shadow mask above the array with a unique Fibonacci lattice hole pattern. All sensors are centrally located under the mask, ensuring that at least one sensor remains in the shade. This shaded sensor is near-homogeneously exposed only to diffuse sky, giving an accurate estimate of diffuse solar irradiance.

Figure 0.2 Inside the SRD100 diffusometer: a detailed look at the core components responsible for performance and durability under extreme conditions.



Measuring direct solar radiation

When combined with a standard pyranometer, users can estimate direct solar radiation by subtracting the two measurements and dividing by the solar zenith angle, which is typically obtained using data from a GPS sensor.

Optimized for clear sky and partly cloudy conditions

The SRD100 is calibrated under clear-sky conditions, ensuring the highest accuracy for blue skies. It is specifically optimized for conditions most relevant to PV applications, such as clear and partly cloudy skies. Measurement accuracy may be lower under grey overcast skies.

This manual gives general information. There are separate manuals covering communication with a PC, programming and register structure, see below. These can be downloaded via <https://hukx.com/downloads>

- Hukseflux Sensor Manager manual
- Hukx programming manual industrial pyranometers and diffusometers
- register list

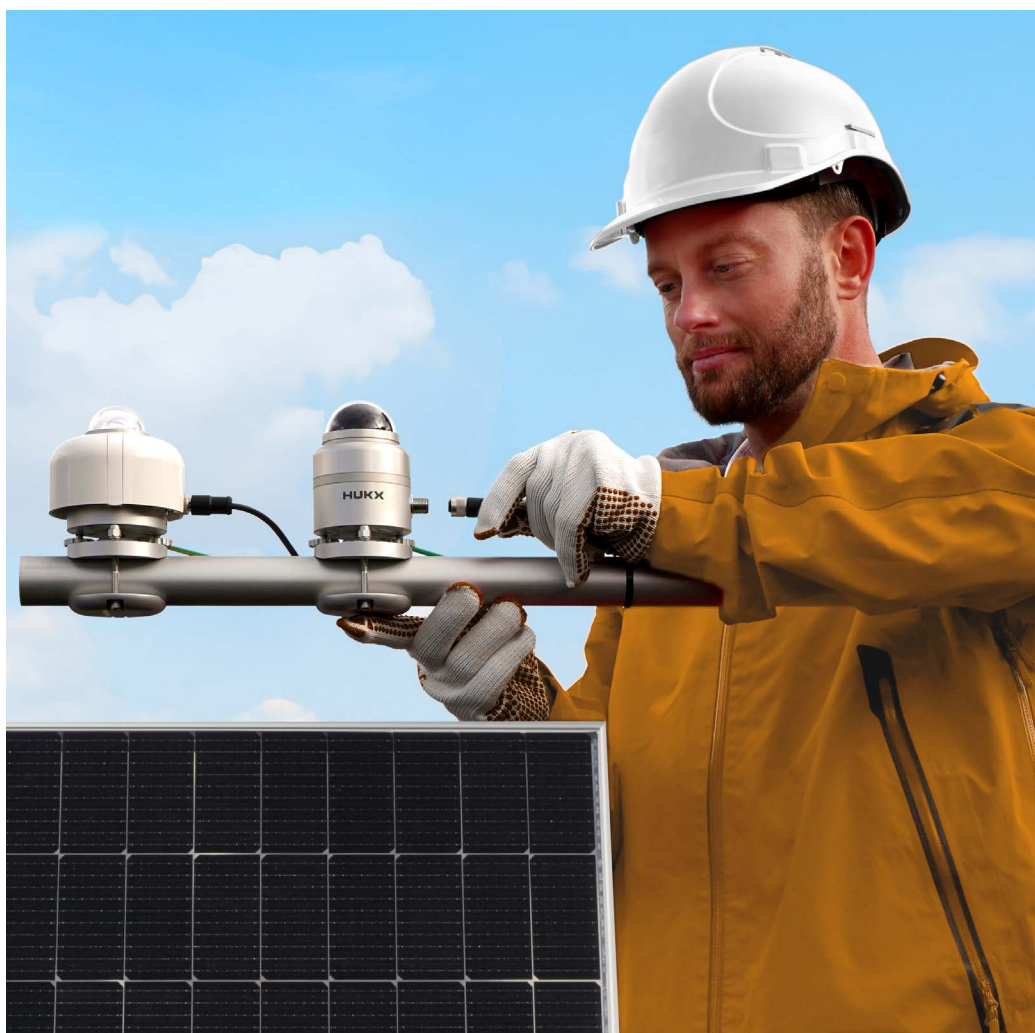

Figure 0.3 Typical installation of SRD100, next to a normal Class A pyranometer, such as the SR300-D1.

Spectrally-matched solar irradiance

For PV performance data analysis, the SRD100 offers a key advantage: it qualifies as a spectrally-matched reference device, according to IEC 61724-1. Its sensor array is made of the same silicon as the most common PV modules, enabling a more accurate estimate of usable solar resources. When comparing SRD100 measurements to the output of silicon-based PV modules, users can claim to measure “spectrally-matched solar irradiance”, with a spectral response of silicon.

PV System performance monitoring: IEC 61724-1 Class A compliant

The SRD100 diffusometer fully meets IEC requirements for diffuse radiation measurements in Class A PV system performance monitoring, without the need for additional accessories. The SRD100 includes:

- onboard heating for dew and frost mitigation
- sensor output traceable to both solar irradiance and spectrally matched solar irradiance

A modern alternative to shadow rings

The SRD100 offers a hassle-free alternative to conventional solutions for diffuse radiation measurement, such as a pyranometer with a shadow ring. Unlike shadow rings, the SRD100 does not require manual adjustment every 2 to 3 days, offering a low-maintenance solution.

A simpler solution than pyrheliometers and rotating shadow bands

Direct and diffuse radiation may also be measured using pyrheliometers, shaded pyranometers, and pyranometers with rotating shadow bands. While these systems are ideal for scientific applications, they can only attain their potentially high levels of accuracy under ideal conditions. For example, pyrheliometers must be kept very clean—more so than pyranometers—and daily cleaning is recommended.

The diffuse and direct measurement with rotating shadow bands relies on post-processing of data. For example, a correction factor dependent on the solar zenith angle, to attain the best accuracy. With post-processing, the data lose their traceability, and thus, their bankability.

Measurement with the SRD100 diffusometer and a standard pyranometer, is a less complicated, low-maintenance and a 100 % traceable alternative.

Immunity to voltages and currents—surges

The SRD100 diffuse solar radiation sensor is tested and certified for Industrial Environments per IEC 61326-1 and IEC 61000-6-2 standards. When designing a measuring system, SRD100 users can achieve several levels of immunity.

To attain the required level of immunity for a given installation, some general system components should be included, such as:

- lightning protection system
- earthing and grounding network
- external surge protection in addition to the native on-board sensor protection

For enhanced protection, the optional Surge Protection Device (SPD01) increases immunity to 4 kV, protecting up to three pyranometers and diffusometers with a single unit. Alternatively, a third-party SPD with similar specifications may also be used.



Figure 0.3 The SPD01 Surge Protection Device.

RS-485 isolation

The SRD100's RS-485 interface is galvanically isolated from both the internal electronics and the instrument body, with isolation barriers rated at 1.5 kV. This ensures reliable operation, greater flexibility in system design, and reduced integration costs for all industrial pyranometers and diffusometers. For more information, see the section on RS-485 network.

Remote diagnostics

In addition to solar irradiance, SRD100 provides several alerts and measurements for remote use, most importantly:

- alert: heating malfunction
- internal humidity

These remote diagnostics minimize the need for (un)scheduled field inspections.

Electrical safety in the workplace

A PV power plant is a potentially hazardous workplace environment. To comply with safety regulations, the SRD100-D1 industrial diffusometer features a dedicated earthing terminal for connection to protective earth. When the diffusometer is isolated from the mounting platform, it should still be properly earthed via this terminal. SRD100-D1 allows system designers to comply with safety regulations. These are often based on EU and US electrical safety standards such as:

- EN-50110 Operation of Electrical Installations
- NFPA 70 National Electrical Code (NEC)



Figure 0.5 SRD100-D1 with yellow/green wire connected to its earthing terminal for compliance with EU and US safety regulations.

Heated for high data availability

SRD100-D1 has built-in heating, which provides dew and frost mitigation for reliable operation in all climates. The heater can be controlled to any duty cycle setting or turned off completely.

Communication with a PC: Hukseflux Sensor Manager software

The Hukseflux Sensor Manager software can be used for communication between a PC and Hukx digital pyranometers, pyrhemometers and diffusometers. The latest version of the Hukseflux Sensor Manager can be downloaded via www.hukx.com/downloads

The Hukseflux Sensor Manager allows users to easily configure the diffusometer, including setting the device address and communication settings. It can also be used to plot and export instrument data, as well as view sensor diagnostics.

See the [Sensor Manager user manual](#).

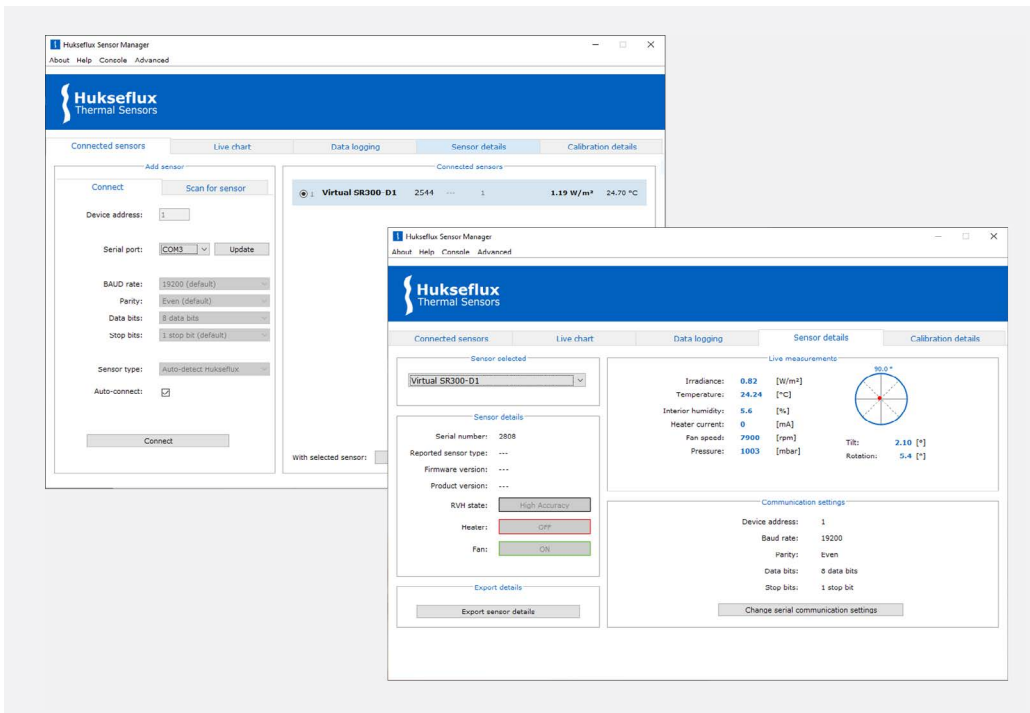

Figure 0.6 The Hukseflux Sensor Manager software allows the user to change the device address and communication settings.

Implementation in a SCADA network: programming manual and register lists

This manual gives directions for electrical connection and implementation in an RS-485 network. For programming, consult the separate “Hukx programming manual industrial pyranometers and diffusometers” and the “register list” document for every sensor model for more details. The latest version of these documents can be downloaded via <https://hukx.com/downloads>

Optional accessories

We offer a range of accessories for the SRD100, including electrical and mounting hardware options. The SRD100’s compact design and small footprint allow the device to be conveniently installed on standard pyranometer mounting plates.

- **SPD01** Surge Protection Device, (for 1 to 3 instruments) for cables longer than 3 meters and to upgrade Surge Protection to level 4
- **PID01** Pyranometer Insulation Disk, electrically insulates the instrument from the mounting platform with a spring-loaded design for easy leveling
- **LM01** spring-loaded leveling mount, simplifies installation with easy mounting, leveling, and instrument exchange on flat surfaces
- **TLM01** tube leveling mount with a set of bolts for secure mounting
- calibration certificate; customized with the customer’s name and contact information
- **PMF01** and **PFM02** mounting fixtures, practical pyranometer mounting fixtures for easy installation in all climates and weather conditions



Figure 0.7 Examples of optional accessories for the most common ways to mount and level SRD100-D1, and also to electrically insulate it from the mounting platform.



Figure 0.8 LM01 leveling mount is the most popular option for SRD100-D1: practical spring-loaded mount for easy mounting, leveling and instrument exchange on flat surfaces. The spring-loaded mounting has the advantage that leveling can be done quickly, without unlocking the instrument.

See also

- [Pyranometer selection guide](#), find the right instrument for your needs
- [Market leading solar radiation sensors](#), explore our full selection of solar measurement solutions

1 Ordering and checking at delivery

1.1 Ordering the SRD100-D1

The standard configuration of the SRD100-D1 is without a cable. The instrument can be ordered with a range of optional accessories, including various mounting brackets or electrical accessories. See the section on optional accessories for a complete list.

The order code consists of the instrument model, optionally followed by the model for mounting brackets and optionally followed by a code for a cable. E.g. to order an SRD100-D1 with TLMB01 mounting bracket and 3 m cable, the order code would be SRD100 D1TLMB01-03. Other accessories can be ordered separately.

Order code:

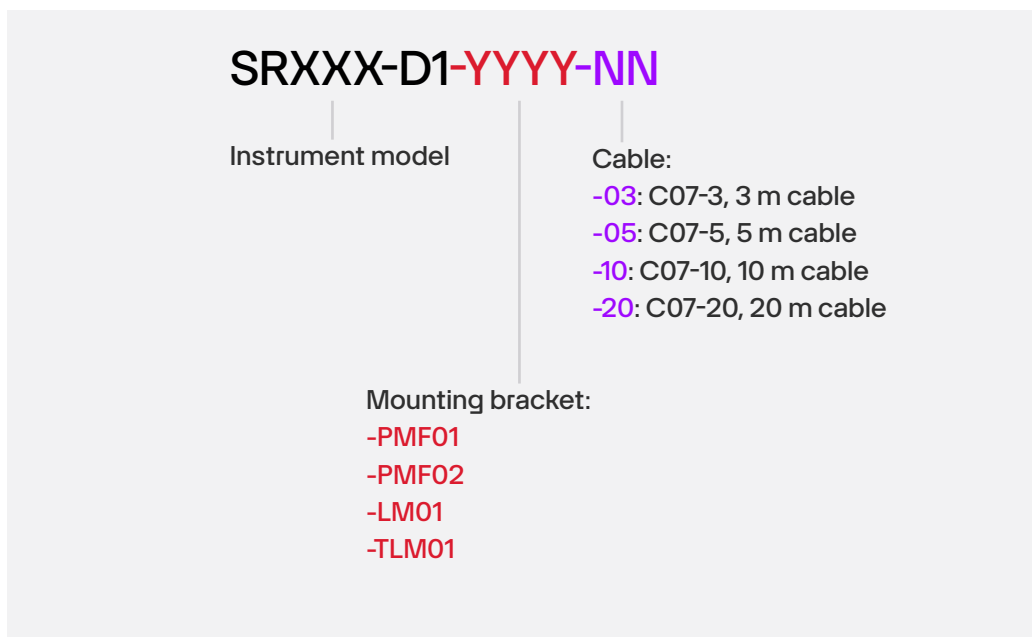

1.2 Included items

Arriving at the customer, the delivery should include:

- diffusometer SRD100-D1
- dome protector DP02
- leveling feet: 1 x fixed + 2 x adjustable
- certificates: calibration certificate
- uninsulated ring terminal with earth screw
- any other options as ordered

1.3 Quick instrument check

A quick check of the instrument can be done by connecting it to a PC and installing the Hukseflux Sensor Manager software. See the chapter on connecting to a PC for directions. Note that a separate power supply is required—the instrument cannot be powered from a USB port.

1. At power-up, the irradiance signal may have a temporary output level different from zero—an offset. Let this offset settle down; it is a normal part of the power-up procedure.
2. Check if the sensor reacts to light: expose the sensor to a strong light source, for instance, a 100 W light bulb at 0.1 m distance. Darken the sensor either by putting something over it or switching off the light. The instrument irradiance output should go down and within one minute approach 0 W/m².
3. Verify that the internal humidity indicator generates a realistic and acceptable value (for new instruments internal humidity below 10 % at room temperature).
4. Inspect the instrument for any damage (for new instruments scratches on domes may be checked according to ISO 10010: see the appendix on optical surface imperfections).
5. Check the instrument serial number, sensitivity etc., programmed in the instrument as indicated by the Hukseflux Sensor Manager software against the label on the instrument and against the certificates provided with the instrument.

2 Instrument principle and theory

2.1 Diffuse solar radiation

Diffuse solar radiation originates from sun light that has been scattered in earth's atmosphere. The dominant scattering process varies drastically depending on cloud coverage, precipitation and concentrations of aerosols and pollutants. This can lead to significant variations in the diffuse irradiance, in addition to variations resulting from seasonal and time of day effects.

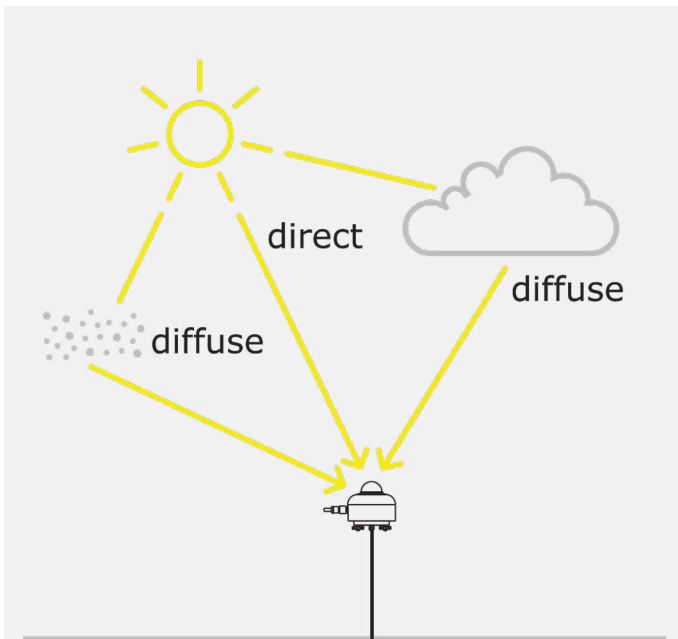

Figure 2.1.1 Diffuse solar radiation is defined as all solar radiation reaching the surface that does not come directly from the sun. It may come from solar radiation scattered by clouds, atmospheric particles, and aerosols.

For clear skies the scattering tends to be dominated by Rayleigh scattering from molecules. Rayleigh scattering is relatively weak and becomes stronger for shorter wavelengths causing the skies to appear blue. In this case, the diffuse irradiance is often just a small fraction of the global irradiance, with typical values ranging from 50 W/m^2 (very clear low humidity, low aerosol) to 150 W/m^2 .

Under overcast conditions, scattering is dominated by Mie scattering. Skies appear white or grey. Under these conditions the direct irradiance becomes negligible and the diffuse irradiance is equal to the global irradiance. Under these conditions the diffuse irradiance can vary over a much wider range. Typically we find higher values than under clear skies, so up to 200 W/m^2 is considered normal. Under partly cloudy skies, we may have diffuse values up to 600 W/m^2 due to reflections of direct irradiance against clouds.

Whereas direct radiation comes from a narrow range of directions centered around the sun, diffuse radiation is spread out over the entire hemisphere. Distinguishing between direct and diffuse radiation can be important for the most accurate estimation of PV panel performance.

2.2 Instrument principle

A diffusometer is a radiometer designed to measure the diffuse solar irradiance on a plane surface parallel to its sensor surface. A diffusometer must separate the direct radiation from the diffuse radiation. There are several methods to accomplish this.

The SRD100-D1 uses an array of silicon sensors combined with a shading mask to accomplish this. The shading mask, with a unique Fibonacci lattice hole pattern, casts a shading pattern onto the sensor grid, ensuring that at any time at least one sensor is shielded from direct sunlight. That sensor is then exposed to diffuse radiation only and can be used to measure the diffuse irradiance.

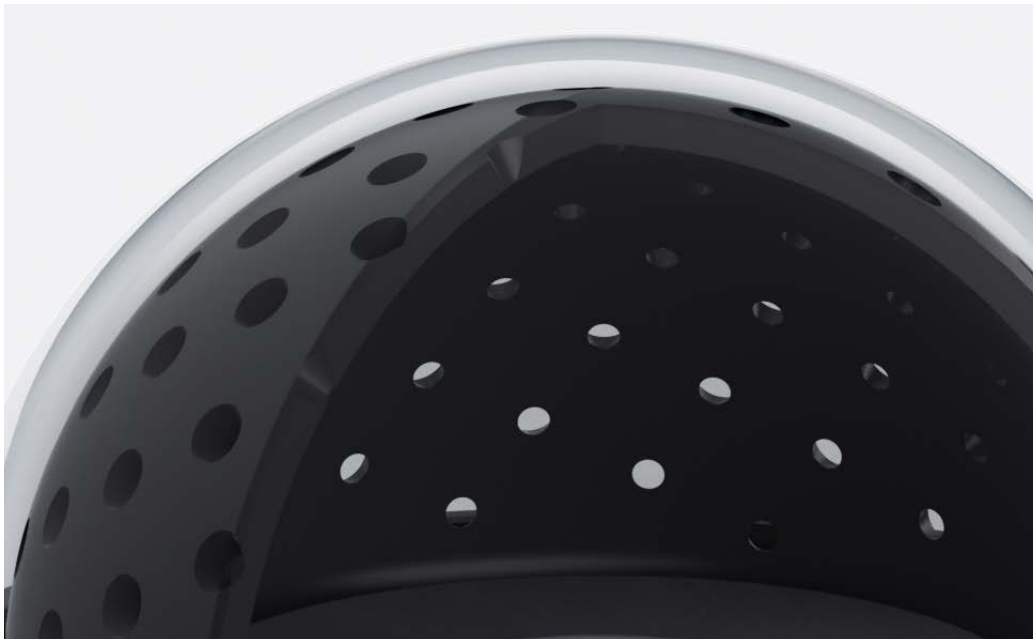

Figure 2.21 Schematic illustration of the SRD100-D1 working principle. The SRD100 D1 diffusometer features a sensor array and half-sphere shadow mask above the array with a unique Fibonacci lattice hole pattern. All sensors are centrally located under the mask, ensuring that at least one sensor remains in the shade. This shaded sensor is near-homogeneously exposed only to diffuse sky, giving an accurate estimate of diffuse solar irradiance.

Each sensor has its own calibration for diffuse irradiance. For each sensor i the sensor output voltage U_i is converted to a diffuse irradiance estimator E_i :

$$E_i = U_i / S_i$$

Sensors may be exposed to direct radiation, however since at least one sensor is guaranteed to be shielded from direct light, the minimum of the diffuse irradiance estimators corresponds to the diffuse irradiance. The measured diffuse irradiance E is calculated by taking the smallest value of the diffuse irradiance estimators E_i :

$$E = \min_i E_i$$

The shading mask blocks a significant part of the diffuse radiation. The correction for this limited view factor is included in the sensitivities S_i during calibration. The apertures in the shading mask are placed on a Fibonacci lattice which provides a near homogeneous sampling of the sky. This prevents sections of the sky from being under- or overrepresented in the diffuse irradiance measurement.

In comparison to other methods for measuring DHI, the combination of a sensor grid with a shading mask allows for a rather compact, low maintenance solution without moving parts.

2.2.1 Sources of error

SRD100-D1 has silicon sensors. When measuring diffuse irradiance in W/m^2 (like a pyranometer with a flat spectral sensitivity), the spectral error is the dominant source of error for SRD100-D1 measurements. As the instrument calibration is traceable to clear sky conditions, the accuracy under these conditions is best. Under cloudy conditions the measurement uncertainty gets higher.

When using SRD100-D1 as a spectrally matched reference device, the spectral errors are no longer there. We then claim the same uncertainty under all conditions.

Other sources of error include zero offsets, non-stability and non-linearity. We consider the latter error sources to be negligible.

Since diffuse irradiance has less spatial variance across the sky than Global Horizontal Irradiance, directional response is a less significant error source for pyranometer GHI measurements. The apertures in SRD100-D1's shading mask provide a near homogeneous sampling of the sky.

SRD100-D1 is designed to minimize errors due to direct irradiance. Nevertheless, there may be some crossover of direct radiation in the diffuse signal. This error is included in the overall uncertainty evaluation of the SRD100-D1 calibration.

For more information, refer to the appendix on sensor performance 8.7.

3 Specifications

3.1 General overview

This chapter provides an overview of the SRD100-D1 specifications, starting with the first paragraph, which gives a general overview of its purpose and offers more detail in later paragraphs.

Instrument purpose and intended use

A diffusometer measures the hemispherical solar radiation minus coplanar direct solar radiation received by a plane surface from a 180 ° field of view angle. This quantity, expressed in $[W/m^2]$, is called diffuse solar radiation. It is intended for ground-based outdoor measurements in all climate types.

Optionally, for performance monitoring of silicon-based PV solar modules, SRD100-D1 may be used as "spectrally matched" reference device according to IEC 61724-1 clause 3.17, for measuring the PV-usable portion of the solar radiation.

Measurement specifications are valid for clean instruments under the rated operating conditions. Diffusometers must be part of a larger system which collects and stores data. This system must preserve the rated operating conditions of the diffusometer.

Diffusometers are defined in ISO 9060. Depending on the application they should be employed and maintained in accordance with the recommended practices of ISO, IEC, WMO and ASTM.

Pyranometers must be part of a larger system which collects and stores data. This system must preserve the rated operating conditions of the pyranometer.

Pyranometers are classified according to ISO 9060. Depending on the application they should be employed and maintained in accordance with the recommended practices of ISO, IEC, WMO and ASTM.

General instrument specifications & compliance

ISO 9060:2018 definition	diffusometer a radiometer designed for measuring diffuse solar radiation, consisting of a pyranometer a shading structure: a shading mask
IEC 61724-1:2021 definition	spectrally matched diffusometer a reference device with spectral response characteristics sufficiently close to those of the PV modules in the PV array such that spectral mismatch error are small under the typical range of incident spectra. Measuring the PV-usable portion of the solar radiation
WMO Measurement Quality Classification (WMO-No. 8, 2023 edition)	Class C
IEC 61724-1:2021 compliance for diffuse radiation measurement	meets Class A PV monitoring system requirements for all locations and climatic conditions

Instrument diagnostics

remote diagnostics alerts

high internal humidity •

remote diagnostics measurements

instrument body temperature •

internal humidity •

heater current •

3.2 Rated operating conditions

The SRD100-D1 is tested for a wide range of operating conditions.

To avoid permanent damage, ensure reliable operation, and measure accurately, the instrument must be operated within the range of conditions listed below.

These conditions are referred to as 'rated operating conditions'.

Additionally, the instrument must be kept clean. Suggestions for a maintenance schedule can be found in the standards in Chapter 4 and in Chapter 7.

Rated operating conditions

calibration

interval < 2 years, as recommended by ISO TR 9901
and required by IEC 61724-1 Class A

environmental

operating temperature range (-40 to +80) °C

electrical

operating voltage (8 to 30) VDC

other

internal relative humidity < 40 %

NOTICE

Measure with a clean instrument and under the rated operating conditions only.
Working outside rated operating conditions may lead to loss of measurement
accuracy, loss of data or permanent damage.

3.3 Diffusometer specifications

For the definition of the ISO 9060 pyranometer classification parameters, see the appendix.

Diffusometer specification according to ISO 9060:2018 where applicable to diffusometers

parameter

response time (95 %)	< 2 s
zero offset a (response to 200 W/m ² net thermal radiation)	none
zero offset b (response to 5 K/h change in ambient temperature)	none
zero offset c (total zero offset)	< ± 1 W/m ²
non-stability	< ± 1% / year
non-linearity	< ± 1%
temperature response	< ± 0.4 % (-30 to +50) °C
tilt response	none
additional signal processing error	none (signal processing errors are included in other specifications)

Additional diffusometer specifications

spectral range (20 % of peak spectral sensitivity points)	(410 to 1070) x 10 ⁻⁹ m
limiting irradiance range	(-400 to 4000) W/m ²
field of view angle	180 °
leveling (see options)	bubble level and adjustable leveling feet are included
leveling accuracy	< 0.6 ° when the bubble is entirely within the ring

3.4 Electrical specifications

The Hukx industrial diffusometer and industrial pyranometers both require external power to operate. These industrial sensors have an isolated RS-485 hardware interface for communication. The instruments feature an M12-A connector for connection to a power supply and an RS-485 network, as well as a dedicated earthing point to connect the instrument body to protective earth (PE). Earthing is achieved through the earthing terminal, which is electrically connected to the instrument body and the connector housing. The connector housing provides an earthing point for the cable shield.

Electrical connection, earthing and isolation

rated operating supply voltage	(8 to 30) VDC
recommended operating voltage	24 VDC
recommended over-current protection	< 1 A slow-blow fuse*
reverse polarity protection	included
hardware interface	2-wire RS-485, separate signal ground wire
RS-485 common mode range	(-7 to +12) V
RS-485 differential mode range	(-7 to +12) V
RS-485 isolation voltage	1.5 kV (DC for 1 minute)
RS-485 needs fail-safe biasing (line polarization)	yes
implements fail-safe biasing (line polarization)	no
earthing terminal	M5 threaded hole in instrument body
recommended maximum cable length	≤ 100 m**

* More information about current over protection can be found under "cabling and surge protection".

** In practice the system design, environmental factors, data communication speed, required operating voltage, use of additional SPD's, etc. will determine possibilities for cable extension. More information can be found under "cabling and surge protection".

The industrial diffusometer and pyranometers are optionally supplied with a cable with one connector and one free cable end. The cable specifications are listed below.

Cable specifications	
available lengths for optional cables	3, 5, 10, or 20 m
conductor cross-section	0.25 mm ² (24 AWG) stranded copper conductors
number of conductors	5
cable shield	braided
cable outer diameter	4.8 mm
connector	M12 A-coded socket connector, 5-pole
cable termination	removed sheath over 0.15 m, stripped ends with ferrules

The SRD100-D1 comes with a factory default setting of 100% duty cycle for the heater. The heater can be controlled to any duty cycle setting or turned off completely. This allows users of SRD100-D1 to save power. Heating has no impact on the SRD100-D1 measurement accuracy, all specifications are valid for all heater settings.

Power consumption	
heated (default setting)	< 2.0 W*
unheated	< 0.5 W
heater duty cycle controlled by the user	between 0.5 and 2 W

* at 100 % heater duty cycle.

The Hukx industrial diffusometer and pyranometers are both suitable for use in industrial environments such as PV power plants. These instruments meet industrial-level EMC requirements and have been designed to withstand electrical surges. EMC specifications and surge immunity specifications under test conditions are listed below.

EMC specifications*

emission	EN-IEC 61326-1:2013 EN-IEC 61326-1:2021
emission limits applied	EN 55011, Class A and B
electromagnetic environment (IEC 61326-1)	industrial
immunity	EN-IEC 61326-1:2013 EN-IEC 61326-1:2021 EN-IEC 61000-6-2:2019
applicable EMC test levels	
electrostatic discharge (EN-IEC 61000-4-2:2009)	level 4 ±15 kV air discharge, ±8 kV contact discharge
electromagnetic field (EN-IEC 61000-4-3:2020)	level 3 10 V/m (80 MHz to 1 GHz) 3 V/m (1.4 GHz to 6 GHz)
burst (EFT) (EN-IEC 61000-4-4:2012)	level 3 ±2 kV with a capacitive clamp at 5 and 100 kHz
surge (EN-IEC 61000-4-5:2014+A1:2017)	level 2 ±1 kV, all lines tested as I/O lines
conducted RF (EN-IEC 61000-4-6:2014)	level 3 10 V/m

* tested assuming shielded cable
(shield connected at both ends)
with a maximum length of 20 m.

Surge test conditions (EN-IEC 61000-4-5:2014 + A1:2017)

surge immunity	level 2
surge test level	±1 kV line-to-ground
coupling network	40 Ω / 0.5 μF
cable	see section on cable specifications
earthing	<ul style="list-style-type: none">– pyranometer earthing terminal– cable shield on pyranometer's side– cable shield connected or disconnected at one or both ends

surge test conditions with optional SPD01

surge immunity	level 4
surge test level	±4 kV line-to-ground ±2 kV line-to-line
coupling network	18 μF
cable section SPD to pyranometer	shielded and ≤ 3 m, see section on cable specifications
cable section SCADA system to SPD	shielded or unshielded*, length not specified
earthing	<ul style="list-style-type: none">– pyranometer earthing terminal– SPD01 earthing terminal– pyranometer cable shield, on both sides

* Cable shield disconnected at one or both ends.

The SRD100-D1 industrial diffusometer acts as a Modbus RTU server that must be combined with a data acquisition system that can act as a Modbus RTU client. The server and client must be configured to have the same serial settings.

Digital communication

communication protocol	Modbus
transmission mode	RTU
BAUD rate settings	9600, 19200, 38400, 115200
data bits	8
parity bits	None (N), even (E), odd (O)
stop bits	1, 2
default serial settings	19200 bits/s, 8 data bits, even parity, 1 stop bit (19200 8E1)
default device address	1
auto-connect serial settings	9600 8E1
boot up time after power reset	8 s

3.5 Environmental

Environmental

rated operating temperature range (IEC 60068-2-14)	(-40 to +80) °C
operating relative humidity range (IEC 60068-2-78)	(0 to 100) %
exposure to liquids and dust IEC 60529 Ingress Protection class	IP67
corrosion resistance	SAE J2334

3.6 Weight and dimensions

Mechanical	
connector	M12-A plug connector, 5-pole
earthing terminal	M5, M5x8 bolt included, 1.5 to 2.5 mm ² M5 ring terminal included
mounting	– 2 x M5 bolt at 46 mm center-to-center distance on north-south axis, maximum insertion depth of 6 x 10 ³ m, requires 4 mm hex key (not included) – 1 x M6 bolt, centered, maximum insertion depth of 6 x 10 ³ m
housing material	anodized aluminum
dome material	optical glass, N-BK7
dome protector	included (1 x model DP01)
net weight excluding cable	< 0.5 kg
gross weight excluding cable	< 0.7 kg
packaging note: cable not included	box of (160 x 115 x 115) mm

NOTICE

Do not turn bolts into the holes beyond the maximum insertion depth.

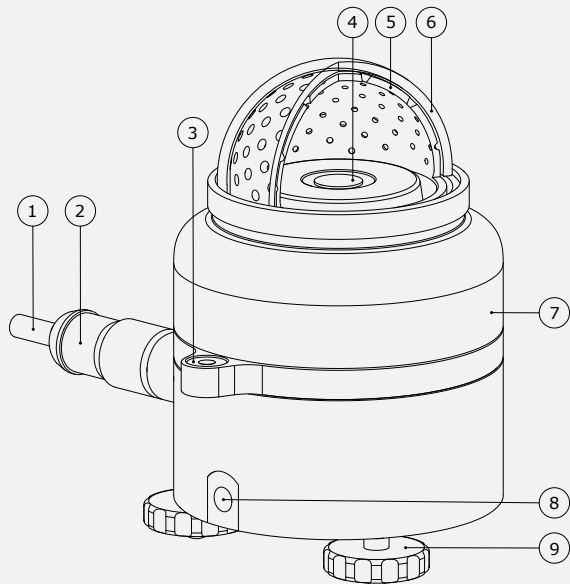

Figure 3.5.1 SRD100-D1 components:

1. signal and power cable
2. 5-pole M12-A connector
3. bubble level
4. sensor array
5. shading mask
6. dome
7. instrument body
8. earthing terminal
9. leveling feet
(1 x fixed, 2 x adjustable)

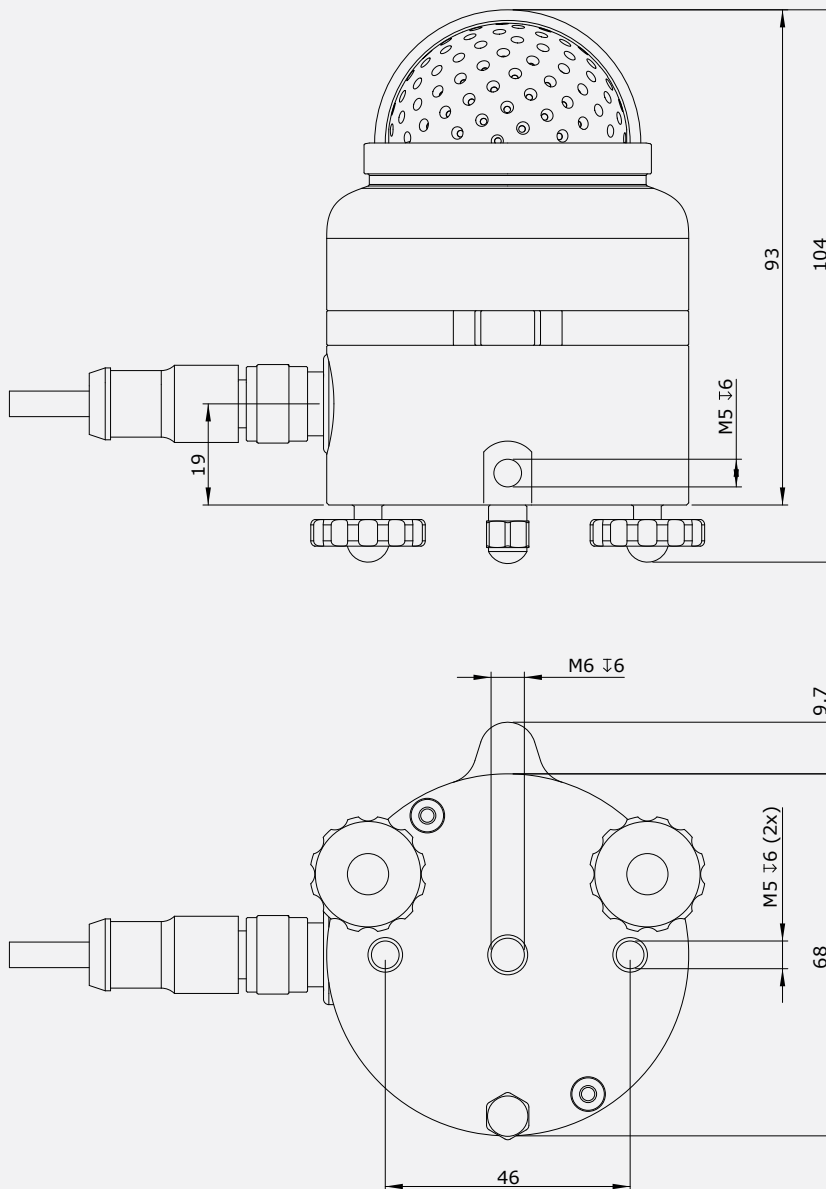

Figure 3.5.2 Dimensions of SRD100-D1.

3.7 Optional accessories

The table provides an overview of accessories that are compatible with the Hukx SRD100-D1.

Accessories	
mounting	
PMF01—mounting fixture for diffusometer or pyranometer	mounting fixture for 1 pyranometer or diffusometer, horizontal or tilted
PMF02—dual pyranometer/diffusometer mounting fixture	mounting fixture for 2 pyranometers, or 1 pyranometer and 1 diffusometer, horizontal and tilted
LM01—Leveling Mount	spring loaded mounting fixture for easy leveling of a pyranometer
TLM01—Tube Leveling Mount	for easy mounting and leveling of pyranometers on a tube
AMF03—Albedo Mounting Fixture	mounting fixture for combining an upward and a downward facing pyranometer, to construct an albedometer
CMF01—Crossarm Mounting Fixture	crossarm mounting fixture for pyranometers, albedometers and net radiometers
electrical	
C07-03—3 m cable	3 m, 24 AWG, 5 pole cable with shielding, one M12-A socket connector and one free cable end
C07-05—5 m cable	5 m, 24 AWG, 5 pole cable with shielding, one M12-A socket connector and one free cable end
C07-10—10 m cable	10 m, 24 AWG, 5 pole cable with shielding, one M12-A socket connector and one free cable end
C07-20—20 m cable	20 m, 24 AWG, 5 pole cable with shielding, one M12-A socket connector and one free cable end
SPD01—Surge Protection Device	surge protection device
PID01—Pyranometer Insulation Disc	Electrically insulating disc for insulating the pyranometer housing from its mounting platform, including spring loaded fixation for easy leveling.

Accessories

software

HSM—Hukseflux Sensor Manager

Free of charge software for use with a PC. Useful for configuring digital Hukx industrial pyranometers

miscellaneous

DP02 set of 5 Dome Protectors

Cover for protecting a pyranometer dome during storage, installation and transport. Set of 5 pieces.

LF01

2 x adjustable leveling feet and 1 x static foot for horizontal installation of the instrument

SF01

static feet for tilted installation of the instrument, set of 3

3.8 Measurands, certificates and calibration

The SRD100-D1 is used to measure instantaneous diffuse solar radiation, also known as Diffuse Horizontal Irradiance (DHI), and statistical information such as average, min/max and standard deviation, all in [W/m^2], over a certain read-out interval. From the average and the read-out interval, the user can also calculate time-integrated diffuse irradiance (radiant exposure) in [$W\cdot h/m^2$].

When used in combination with a pyranometer for the measurement of Global Horizontal Irradiance (GHI), users can calculate Direct Normal Irradiance (DNI) and sunshine duration. Both calculations require a real time clock and post processing of measurement data.

The relevant equations are

$$DNI = (GHI - DHI)/\cos(\theta) \quad (\text{Formula 3.7.1})$$

where θ is the solar zenith angle.

The WMO sunshine criterion can be expressed by

$$DNI = (GHI - DHI)/\cos(\theta) > 120 \text{ W/m}^2 \quad (\text{Formula 3.7.2})$$

which is applicable to instantaneous readings

The instrument body temperature is measured in order to perform temperature compensation of the irradiance output.

Irradiance measurement

measurand	instantaneous diffuse solar radiation
measurand in SI radiometry units	irradiance in W/m ²
uncertainty of the measurement	statements about the overall measurement uncertainty can only be made on an individual basis. see the appendix on uncertainty evaluation
achievable uncertainty (95 % confidence intervals)	< ± 10 % (clear skies, partly cloudy skies) < (+20 % ± 20 %) (overcast) see the appendix on uncertainty evaluation for details
optional measurand	spectrally matched diffuse solar radiation (matching to silicon)
measurand in SI radiometry units	irradiance in W/m ²
uncertainty of the measurement of the optional measurand	statements about the overall measurement uncertainty can only be made on an individual basis. see the appendix on uncertainty evaluation
achievable uncertainty (95 % confidence intervals)	< ± 10 % (clear skies, partly cloudy skies) < ± 10 % (overcast) see the appendix on uncertainty evaluation for details
statistical information	on (spectrally matched) diffuse solar radiation: – average – min/max – standard deviation
measurement interval for statistical information	read-out interval (statistical parameters are reset to zero at the moment of read-out of the register)

use of the measurand

measurements can be used for the quantities:

- (spectrally matched) diffuse Horizontal Irradiance
- (spectrally matched) diffuse solar radiation in any plane

measurements may also be used as input quantity to calculate:

- Time-integrated solar irradiance or radiant exposure in [W·h/m²]. Calculated by the user: average multiplied by read-out interval

in combination with a pyranometer to measure Global Horizontal Irradiance, measurements may also be used as input quantity to calculate:

- Direct Normal Irradiance
- Sunshine duration (both require a real-time clock and some post-processing)

input quantity

instrument body temperature

instrument body temperature measurement uncertainty

± 1 °C

The SRD100-D1 is supplied with a calibration certificate.

Certificates and reports

calibration certificate

•

Specifications for factory calibration can be found in the table below. New instruments are provided with factory calibrations. A new calibration, as specified below, is available upon request.

Calibration

uncertainty ($k = 2$)	< 1.2 %
traceability	to WRR
hierarchy	from WRR through ISO 9846 and ISO 9847
method	Hukx Diffuse Radiation Calibration, ISO 9847:2023 type A2
level of accreditation	ISO 9001:2015
certificate content	Hukx issues calibration certificates with content limited as per ISO/IEC 17025, section 7.8.1.3. Such a certificate contains the calibration result, an uncertainty, a description of the calibration procedure and the traceability. As an option, a certificate including name and contact information of the customer may be ordered
rated calibration interval	< 2 years
reference conditions	20 °C, diffuse solar radiation, horizontal mounting, irradiance level 100 W/m ² , ASTM G173-03 diffuse horizontal irradiance spectrum
validity of calibration	Based on experience, the instrument sensitivity will not change during storage. During use under exposure to solar radiation the instrument "non-stability" specification is applicable. The starting date of installation in the field may be used as starting date for the calibration interval
calibration records history and metadata	Records of the present calibration result and previous calibration results are stored in the instrument memory, including sensitivity, date of calibration and calibration traceability.
The data structure is prepared for the expected WRR calibration scale shift.	A metadata calibration traceability value of "0" denotes traceability to WRR. Consult Appendix 8.2 for more details on calibration traceability.
Recalibration: right to change diffusometer sensitivity	When recalibrating digital sensors, the new sensitivities and calibration date must be entered into the diffusometer memory. Owners of Hukx brand digital diffusometers as well as any of its subcontractors have permission to - and will get - all necessary support for change of sensitivities of purchased instruments over the entire life of these instruments.

4 Standards and recommended practices for use

Diffusometers are defined in the ISO 9060 standard. Depending on the application, the instrument may be used in accordance with the recommended practices of ISO, IEC, WMO and/or ASTM.

4.1 Classification standards

Table 4.1.1 Standards for diffusometer classification. See the appendix for definitions of diffusometer specifications.

Standards for instrument classification		
ISO standard	equivalent ASTM standard	WMO
ISO 9060:2018 <i>Solar energy—Specification and classification of instruments for measuring hemispherical solar and direct solar radiation</i>	Not available	WMO-No. 8 <i>Guide to Meteorological Instruments and Methods of Observation</i> , Volume 1, Measurement of Meteorological Variables, 2023 edition, chapter 7, measurement of radiation, 7.3 measurement of global and diffuse sky radiation

4.2 General rules for solar radiation measurement

The SRD100-D1 diffusometer has much in common with a pyranometer, and the instrument will typically be used together with a pyranometer. Recommended practices for use are similar to those for pyranometers. We therefore refer to practices for pyranometers and trust that users will be able to decide which recommendations are applicable, and which are not.

Table 4.2.1 Standards with recommendations for instrument use in solar radiation measurement.

Standards for instrument use for hemispherical solar radiation		
ISO standard	equivalent ASTM standard	WMO
ISO/TR 9901:2021 <i>Solar energy—Pyranometers—Recommended practice for use</i>	ASTM G183-15R23 <i>Standard Practice for Field Use of Pyranometers, Pyrhemometers and UV Radiometers</i>	WMO-No. 8 <i>Guide to Meteorological Instruments and Methods of Observation</i> , Volume 1, Measurement of Meteorological Variables, 2023 edition, chapter 7, measurement of radiation, 7.3 measurement of global and diffuse solar radiation Baseline Surface Radiation Network, BSRN Operations Manual (WMO / TD No 1274, L. J. B. McArthur, April 2005)

4.3 Specific use in meteorology and climatology

The World Meteorological Organization (WMO) is a specialized agency of the United Nations. It is 'the UN system's authoritative voice on the state and behavior' of the earth's atmosphere and climate. WMO publishes *WMO-No. 8 Guide to Meteorological Instruments and Methods of Observation*, 2023 edition.

Another useful source is the Baseline Surface Radiation Network, BSRN Operations Manual (WMO / TD No 1274, L. J. B. McArthur, April 2005)

4.4 Specific use for PV system performance testing

IEC has issued a series of 3 standards for PV system performance testing.

- IEC 61724-1, "*monitoring*" giving requirements for measuring
- IEC TS 61724-2 "*capacity evaluation method*" defining performance analysis based on the monitoring data over a short period of several sunny days, typically during commissioning and typically to verify if the system meets specification
- IEC TS 61724-3 "*energy evaluation method*" defining performance analysis based on the monitoring data over a long period of 1 year or longer

Pyranometers and diffusometers are used for monitoring PV power plant efficiency, in order to measure incoming solar radiation independently from the PV system.

IEC 61724-1 mentions diffuse radiation as an option in Class A monitoring systems

- for bifacial systems, to better estimate rear-side irradiance and to judge if trackers point in the right direction (if this is not detected by tilt sensors or tracker control)
- for concentrated PV (CPV) systems with $< 20 \times$ concentration

IEC 61724-1 requires the measurement of diffuse irradiance for Class A systems

- for concentrated PV systems with $> 20 \times$ concentration

And, IEC 61724-1 states that, in case bifacial modules are used, the rear-side solar irradiance may

- be directly measured
- be estimated using an optical model from GHI, albedo, and optionally diffuse irradiance

Table 4.3.1 Standards with recommendations for instrument use in PV system performance testing.

Standards on pv system performance testing	
IEC / ISO standard	Equivalent ASTM standard
IEC 61724-1 <i>Photovoltaic system performance monitoring—guidelines for measurement, data exchange and analysis</i>	ASTM E2848-13 <i>Standard Test Method for Reporting Photovoltaic Non-Concentrator System Performance</i>
SRD100-D1 complies with the IEC 61724-1:2021 requirements of Class A PV monitoring systems for diffuse irradiance measurements for all locations and climatic conditions	
IEC 61724-1 requires that all sensors in Class A monitoring systems are cleaned every week (unless it can be proven this is not necessary) and calibrated every 2 years.	

4.5 General use for sunshine duration measurement

According to the World Meteorological Organization (WMO, 2023), sunshine duration during a given period is defined as the sum of that sub-period for which the direct solar irradiance exceeds 120 W/m².

When used in combination with a pyranometer for the measurement of Global Horizontal Irradiance (GHI), SRD100-D1 users can calculate Direct Normal Irradiance (DNI) and sunshine duration. This requires a real time clock and post processing of measurement data.

The relevant equations are

$$DNI = (GHI - DHI)/\cos(\theta) \quad (\text{Formula 4.5.1})$$

where θ is the solar zenith angle.

The WMO sunshine criterion can be expressed by

$$DNI = (GHI - DHI)/\cos(\theta) > 120 \text{ W/m}^2 \quad (\text{Formula 4.5.2})$$

which is applicable to instantaneous readings.

Table 4.5.1 Standards with recommendations for instrument use in sunshine duration measurement.

Standards for instrument use for sunshine duration

WMO-No. 8 *Guide to Meteorological Instruments and Methods of Observation*, Volume 1, Measurement of Meteorological Variables, 2023 edition, chapter 8, measurement of sunshine duration, 8.2.2 Pyranometric Method

4.6 Using pyranometer data to improve measurement accuracy

The SRD100-D1 is designed to be used in combination with a pyranometer for Global Horizontal Irradiance measurements.

The SRD100-D1 has been calibrated with traceability to clear sky conditions. Due to the spectral sensitivity of the SRD100-D1, measurements under overcast skies will include a systematic overestimation of diffuse irradiance.

Under fully overcast conditions, there is no Direct Normal Irradiance in the pyranometer signal, meaning the pyranometer measurement is representative of the Diffuse Horizontal Irradiance.

A simple algorithm to apply is to take the SRD100-D1 output as Diffuse Horizontal Irradiance, unless the pyranometer output is smaller than the SRD100-D1 output. In those cases, take the pyranometer output as Diffuse Horizontal Irradiance.

$$DHI = E_{SRD100} \quad (E_{pyranometer} \geq E_{SRD100}) \quad \text{(Formula 4.6.1)}$$

$$DHI = E_{pyranometer} \quad (E_{pyranometer} < E_{SRD100}) \quad \text{(Formula 4.6.2)}$$

4.7 Reducing environmental impact

The SRD100-D1 diffusometer reduces environmental impact with respect to competing instruments, due to:

- lower power consumption during use
- robustness and reliability, reducing sensor failures
- the addition of standard dome protectors, mitigating the risk of damage to the pyranometer dome, reducing the need for unnecessary repairs
- a compact packaging design: smaller, lightweight, plastic-free and fully recyclable

As a user, you may reduce environmental impact by:

- use instrument heating only if needed

4.8 Reducing total cost of ownership

Customers prefer Hukx instruments for their unsurpassed measurement accuracy and their lowest total cost of ownership. Total costs are mainly determined by costs of installation, on-site inspections, servicing and calibration:

- coordinating internal and external surge protection and electrical insulation reduces the requirements for added protection devices, for example on the data bus
- reduction of unnecessary on-site inspection by remote diagnostics
- reduction of unnecessary repair costs using a dome protector

5 Installation

This chapter describes the installation of SRD100-D1. Aspects to be considered include:

- finding a suitable location for performing measurements
- mounting the instrument
- the electrical installation of the instrument including earthing and surge protection
- configuring the instrument communication settings

These aspects are interdependent, and the full content of this chapter should be considered when installing a pyranometer.

5.1 Site selection

The SRD100-D1 has a field of view with a 180 ° full field of view angle. This should be considered when selecting a suitable location for installation of the instrument. Preferably, the field of view of the diffusometer should be unobstructed by nearby obstacles (e.g. buildings, trees, etc.).

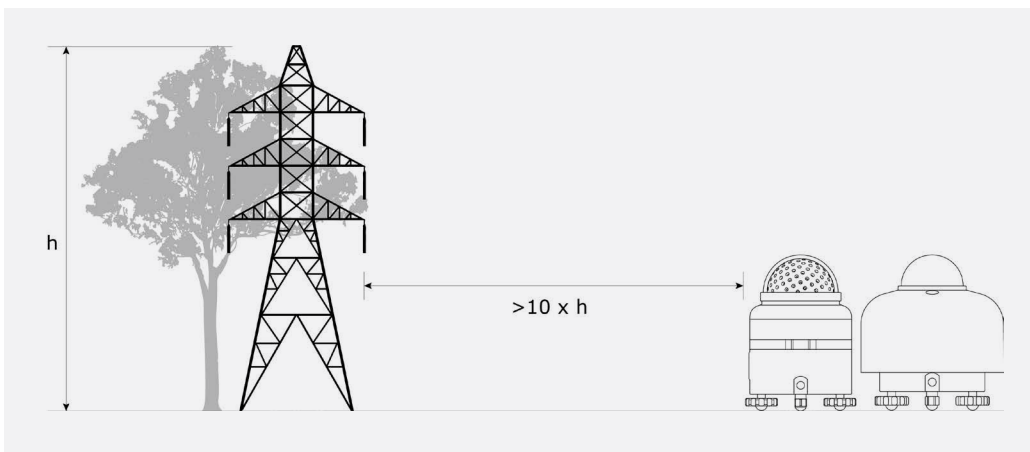

Figure 5.1.1 Preferably, the field of view of the diffusometer should be unobstructed by nearby obstacles. If obstructions are present, as a rule of thumb the diffusometer should be installed at least 10 times the height of the obstruction away from the obstruction.

For measuring Diffuse Horizontal Irradiance (DHI), the diffusometer should be installed with the sensor surface aligned horizontally facing upward. The bubble level and leveling feet should be used to align the instrument. When installing in a horizontal orientation, by convention, the cable exit should point to the nearest pole, so the cable exit should point north in the northern hemisphere, south in the southern hemisphere.

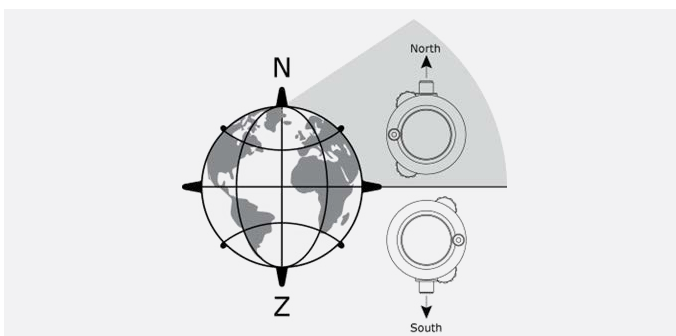

Figure 5.1.2 By convention, when installing the pyranometer in a horizontal orientation, the connector should be pointing north on the northern hemisphere and south on the southern hemisphere.

5.2 Configuring the instrument

The SRD100-D1 acts as Modbus RTU server, responding to requests from a Modbus RTU client device. The Modbus RTU protocol operates on a serial RS 485 data bus to which multiple instruments can be connected. See the section about setting up Modbus RTU communications. Each instrument on the data bus shares the same serial communication settings but must have a unique device address. Specifically, the serial baud rate, parity bit and stop bit settings should be set to match that of all connected Modbus client devices. To operate an SRD100-D1 in a SCADA network, the instrument must be properly configured before installation. The instrument's default settings can be found in the section about electrical specifications.

NOTICE

Each device on the RS-485 network should have the same serial communication settings.

NOTICE

Each Modbus device on the RS-485 network should have a unique device address.

The SRD100-D1 is most easily configured by connecting it to a personal computer (PC) or laptop and accessing the instrument through the Hukseflux Sensor Manager software. Consult the Hukseflux Sensor Manager manual for more details on how to use this software. Alternatively, third-party software which supports the Modbus RTU protocol can be used.

The easiest way to connect to the RS-485 interface is to use a USB-to-RS-485 converter. See the section on how to connect to a PC. On MS Windows®, these converters are usually auto-configured and a virtual serial port becomes available on the system. If not, consult the USB-to-RS-485 converter documentation. This port can be used by the controlling software to communicate with the instrument.

Setting the device address and serial communication settings (baud rate and parity) can be done in different ways:

- by connecting the sensor to a PC and using the Hukseflux Sensor Manager
- by connecting the sensor to a PC and using another Modbus testing tool.
There are links to different solutions available at www.modbus.org
- by using the available network user interface software

For more details about programming, consult the separate "Hukx programming manual industrial pyranometers and diffusometer" and the "register list" for your sensor model. Both documents can be found on our website:

<https://hukx.com/downloads>

5.2.1 Adjusting irradiance sensitivity

Irradiance calibration of a digital industrial pyranometer is generally followed by adjustment of the programmed irradiance sensitivity. Updating the sensitivity is most easily done using the Hukseflux Sensor Manager. The instrument keeps a historic record of up to 32 updates of the calibration data, including the irradiance sensitivity, calibration dates and metadata on the calibration scale. Consult the Hukseflux Sensor Manager manual for detailed instructions.

5.3 Mechanical installation of the instrument

This section describes the mounting of the instrument, and the mounting of the connector and removal of the dome protector.

5.3.1 Instrument mounting

The SRD100-D1 can be mounted using the two M5 mounting points, or the M6 mounting point in the center. See the section about weight and dimensions for details.

Hukx offers a range of compatible mounting accessories, see sections about optional accessories and optional mounts.

When using the SRD100 D1 in a horizontal position to measure Diffuse Horizontal Irradiance (DHI), install the instrument on the provided leveling feet. The leveling feet allow the instrument to be installed in a horizontal position even if the mounting platform is not perfectly horizontal. The leveling feet are used in combination with the bubble level to align the instrument. By convention, when installing the instrument in a horizontal orientation the cable exit should point to the nearest pole, i.e. north on the northern hemisphere and south on the southern hemisphere.

When installing the SRD100 D1 in Plane of Array (POA), the instrument should preferably be installed using 3 fixed feet instead of the leveling feet. See the chapter on optional accessories. Having the leveling feet in place can result in significant misalignment between the sensor surface and the PV modules. By using fixed feet the instrument can be installed parallel to its mounting platform. When installing the instrument in Plane of Array, keep the connector exit pointing downward to reduce the possibility of moisture ingress.

NOTICE

Use fixed feet for Plane of Array (POA) installation.

NOTICE

When installing the SRD100 D1 in Plane of Array (POA) the connector should preferably point downward to avoid moisture ingress.

Mechanical installation cannot be separated from electrical installation. Mounting the diffusometer on an electrically conducting (or insulating) platform may electrically connect (or isolate) the instrument housing from the mounting platform. The instrument mounting should not be relied upon for earthing of the instrument; instead the dedicated earthing terminal must be used. Consult the following section on electrical installation design for more information.

5.3.2 Connecting the instrument cable

The SRD100 D1 is equipped with an M12-A plug connector. When connecting a cable to the instrument, ensure that the screw lock on the cable socket connector is completely tightened, as illustrated in the figure below. While tightening the screw lock, push the connector further into the instrument to fully secure the connector onto the instrument.

NOTICE

Failure to properly tighten the screw lock on the connector can cause poor electrical connection of conductors and cable shield and poor sealing allowing moisture to enter the connector.

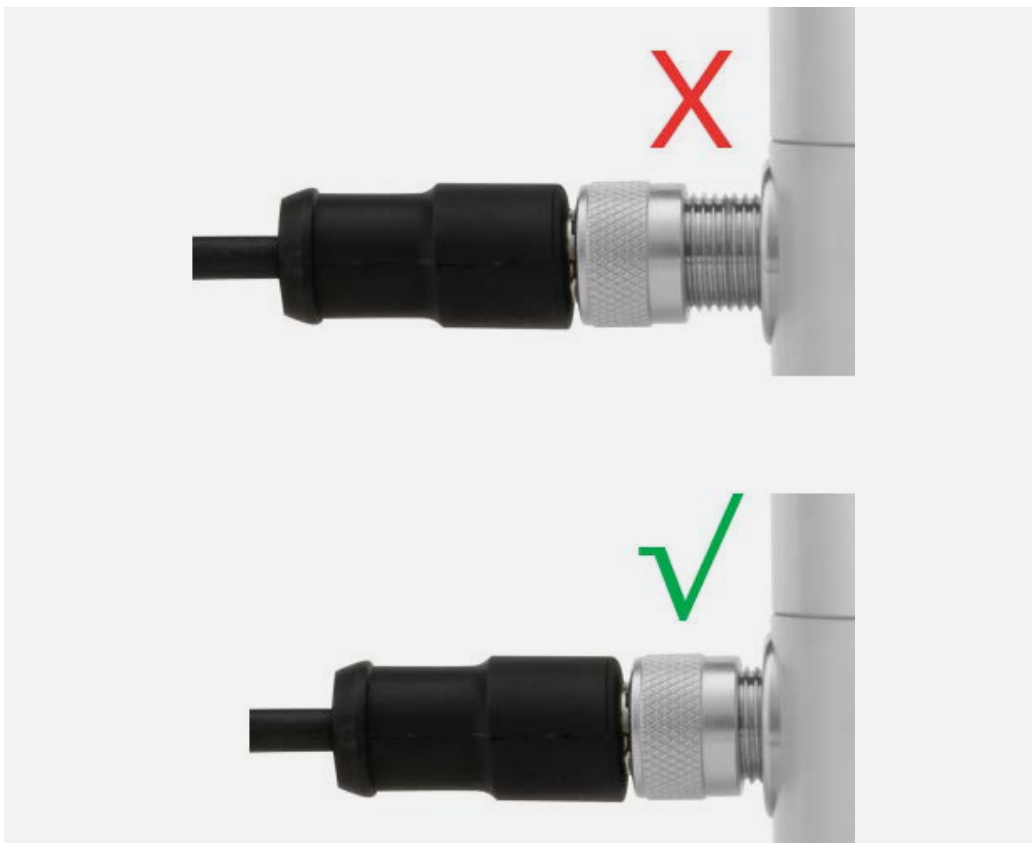

Figure 5.3.4.1 Connection of the cable connector to the chassis connector: make sure to completely tighten the screw lock. This is necessary for proper sealing against moisture and proper electrical connection of conductors and cable shield.

5.3.3 Installation and removal of the dome screen

The SRD100-D1 is supplied with the DP02 dome protector to prevent damage during transport, installation and removal. To remove the dome protector, press on both sides of the dome protector and lift it off the instrument, as illustrated in the figure below. Remove DP02 before you start measuring.

We strongly recommend using DP02 when transporting, installing, and removing the SRD100-D1. This also applies to scenarios such as transporting the instrument to the installation site or when shipping the instrument to an external calibration laboratory.

NOTICE

Always use the DP02 dome protector when transporting, installing and removing the SRD100-D1. Failure to place the dome protector onto the instrument's dome, may unnecessarily lead to damage to the instrument optics.



Figure 5.3.3.1 The SRD100-D1 is supplied with a DP02 dome protector.

5.3.4 Optional mounts

Hukx offers a range of mounting options. See the section about optional accessories for an overview of all accessories. Consult the individual manuals of the mounting accessory for installation instructions.



Figure 5.3.6.1 Overview of Hukx mounting options.

- 1. TLM01,
- 2. PMF02
- 3. PMF01
- 4. PID01
- 5. AMF01

5.3.4.1 Leveling mount LM01

The optional leveling mount, for simplified mounting and leveling of the SRD100-D1 on a flat surface, such as a platform or bracket, is easy to use. It can be fitted to the diffusometer using the mount's spring-loaded center bolt and a 4 mm hex key or a 10 mm spanner. It can be mounted on a flat surface by inserting two M5 bolts (not included) into the designated holes.



Figure 5.3.4.1.1 Optional spring-loaded leveling mount for Hukx SRD100-D1.

Different ways to connect the mount to the pyranometer and lock its connection, are illustrated in the figures below. The preferred way is using a 4 mm hex key via the bottom part of the leveling mount. If the bottom part is not accessible, the connection between the SRD100-D1 and the mount can be made by using a 10 mm spanner. The spanner may be used as well to lock, or unlock, when the pyranometer is already fitted to the mount.

In all cases, ensure the feet of the pyranometer fit into one of the small ledges of the leveling mount. Locking is achieved when the nut of the spring-loaded center bolt is turned all the way towards the bottom panel of the pyranometer.

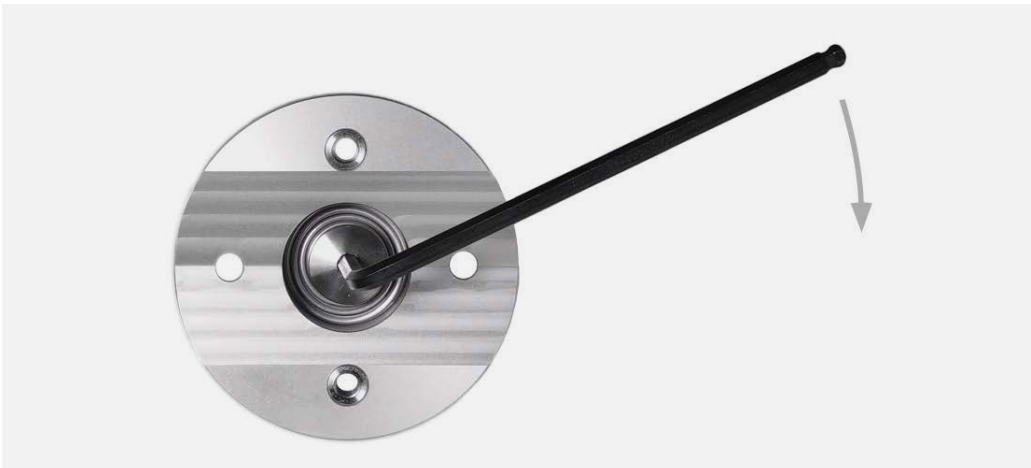

Figure 5.3.4.1.2 Bottom of LM01 leveling mount. Preferred (un) locking with 4 mm hex key.



Figure 5.3.4.1.3 LM01 leveling mount seen from above: (un) locking with a 10 mm spanner.



Figure 5.3.4.1.4 LM01 leveling mount seen from the side: (un) locking with a 10 mm spanner.

The leveling mount is spring-loaded. Once the SRD100-D1 is connected and locked to the leveling mount, it can be levelled by the user using the bubble level as a reference. Leveling is done by turning the two adjustable leveling feet by hand. The static foot remains fixed.



Figure 5.3.4.1.5 SRD100-D1 locked on its optional leveling mount: by fastening (on the left) or loosening (on the right) the two adjustable feet, the pyranometer can be levelled, using the bubble level as a reference. The static foot remains fixed. In all cases, ensure the legs of the pyranometer fit into one of the small ledges of the leveling mount. Locking is in place, when the nut is turned all the way against the bottom plate of the pyranometer.

5.3.6.2 Tube leveling mount LM01

SRD100-D1 may also be mounted on a tube or a mounting rod using the optional tube leveling mount.



Figure 5.3.6.2.1 SRD100-D1 mounted with its optional tube leveling mount on a tube.

The tube leveling mount option includes the leveling mount, described in the previous paragraph, a lower clamp for tube mounting and two sets of bolts for tube diameters 25 to 40 mm (tube not included). Installation requires a 4 mm hex key.



Figure 5.3.6.2.2 Optional tube leveling mount; installation requires a 4 mm hex key.

5.4 Electrical installation design

Reliable operation of Hukx "industrial" sensors - SRD100-D1 is one of these -, is only guaranteed when the electrical installation is done according to the guidelines provided in this manual. Especially the immunity to surges depends on the quality of the cabling, earth grounding and equipotential bonding to external protection devices. In addition, a lightning risk assessment is strongly recommended to adjust lightning protection measures to be balanced with the present risk for damage by lightning.

5.4.1 Lightning protection

Any outdoor installation is vulnerable to nearby and direct lightning strikes. To reduce the risk of permanent damage we advise to install lightning protection. Lightning strikes can be direct or indirect. Direct strikes can be avoided by installing lightning rods. The location and height of these rods follows from a lightning risk analysis.

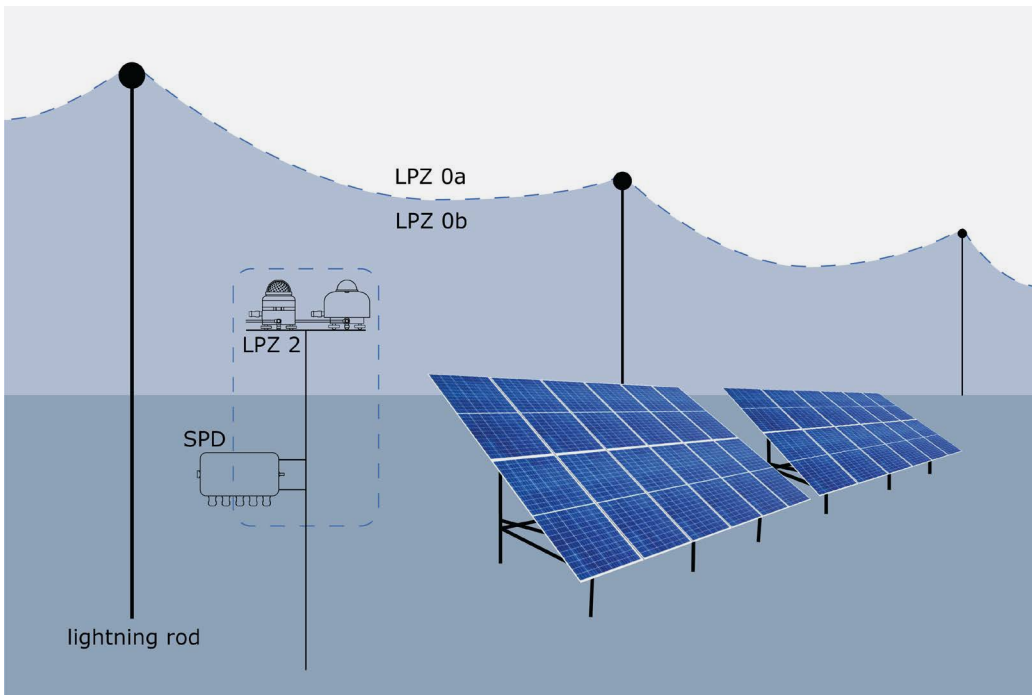

Figure 5.4.11 Hukx industrial sensors, including SRD100-D1, should be installed in LPZ2. Hukx SPD01 is a type 2 SPD which is used on the zone boundary from LPZ0b to LPZ2.

Damage from indirect lightning strikes takes place through the mounting structure and cabling attached to the instrument and SCADA system. To reduce the risk of damage from indirect lightning strikes, appropriate surge protection is needed. The lightning risk analysis provides guidance in selecting the correct type of SPD. In general, the SRD100-D1 should be installed in lightning protection zone 2 (LPZ2) as defined in IEC 62305-4:2010 section 4.3. On each zone boundary, an SPD of the correct type should be installed as indicated in Figure 5.4.11. For example, the Hukx SPD01 is a type 2 SPD, which is used on the zone boundary from LPZ0b to LPZ2.

5.4.2 Cabling and surge protection

An optional cable may be supplied with the instrument. This cable is used to connect the instrument directly to a SCADA system or via a Surge Protection Device (SPD), such as the SPD01, to a SCADA system. When designing a system for outdoor use in industrial environments take note of the following points:

- EMC specifications of the instrument and, more specifically, surge immunity specifications depend on design of the entire electrical installation and are the responsibility of the user.
- Consider the risk of surges due to lightning strikes or high-power switching events at the installation site to decide if an SPD is needed to protect the instrument
- Keep cable connecting instruments to a SCADA system as short as possible, longer cables are more susceptible to electrical disturbances such as electrical surges.
- The SPD01 can be used to protect up to 3 instruments that are installed close together.

NOTICE

For instruments that are integrated into a larger system, EMC and surge immunity specifications depend on design of the entire electrical system and are the responsibility of the user.

NOTICE

Follow the recommendations of this manual for electrical system design. Keep cables as short as possible and resistance to earth as low as possible.

Cabling from the instrument to the SCADA system can be extended to an arbitrary length not exceeding the maximum length allowed for RS 485 systems.

From the point of view of instrument specifications, there is no limit to the cable length. In reality the system design, environmental factors, data communication speed, required operating voltage, use of additional SPD's etc. will determine possibilities for cable extension. In practice, 100 meters (328 ft) is an economical, safe, and reliable maximum to work with, which is why we recommend this as a maximum. When extending cables the following must be considered:

- The conductor cross-section or wire gauge (AWG) of the power wires, the corresponding electrical resistance of those wires and the resulting voltage drop. Ensure that the voltage at the location of the instrument never drops below the minimum operating voltage taking the worst-case situation with the maximum in-rush current for each device attached to the power wires.
- Noise pick-up by long signal cables may cause communication failures. To reduce this effect, use well-shielded cables with twisted wire pairs
- Cables must be suitable for permanent outdoor use.
- Consider the use of shielded cables to improve electromagnetic immunity and reduce electromagnetic emissions.
- Consider the use of cable with twisted pairs to improve electromagnetic immunity and reduce electromagnetic emissions.
- Use of an SPD is another possibility to increase immunity, thereby allowing the use of longer cables.

NOTICE

Adding components to the system such as surge protection devices may lead to surge immunity higher than those specified under test conditions also potentially allowing use of cables to the SCADA system longer than the recommended maximum.

When working with an instrument directly connected to a power supply, to reduce the risk of fire and secondary damage to the instrument or power supply, it is good practice to install a slow-blow fuse (not a fast-blow fuse) on the power supply.

In case an SPD is used, note that use of slow blow fuses may be mandatory because in case of a failure, SPD's (such as SPD01) are designed to cause an electrical short between VDC[+] and VDC[-]. This is to protect the instruments in case the SPD fails to perform its function.

In case multiple instruments are connected to one power supply, multiply the advised current rating of the fuse with the number of instruments attached to the power supply.

⚠ CAUTION

To reduce the risk of fire, install a slow-blow fuse on the power supply.

The instrument cable shield should be connected to earth ground on both sides to meet the EMC specifications and surge immunity as listed in the tables in Section 3.4. On the instrument-end the cable shield is connected to the instrument body, and is connected to the earth by connecting the instrument body to the earth using the earthing terminal, see next section. In cases where it is not possible to connect the cable shield at both ends, e.g. because of earth potential differences, it may be left disconnected at one end, but EMC specifications (emission and immunity) of the resulting installation may deviate from the specifications in Chapter 3.

NOTICE

EMC specifications (emission and immunity) are only valid when a shielded cable is used which is connected at both ends.

When pyranometers are used in non-industrial environments, for example, in indoor experiments, users may decide to require compliance with lower-than-industrial levels of surge immunity.

5.4.3 Earth ground

Equipotential bonding is particularly important when protecting instruments with an SPD. Neglecting to create a low-resistance connection between the SPD and the instrument make the SPD ineffective and may result in permanent damage to the instrument. Using the cable shield for this is discouraged as this also puts the instrument at risk of damage due to interference in the cable shield.

⚠ CAUTION

The absence of a low-resistance connection (equipotential bond) between a pyranometer and SPD may reduce the effectiveness of surge protection.

Hukx industrial sensors and the optional SPD01 both feature an earthing terminal indicated by an earth ground symbol (\perp). See the figure below.

Both earthing terminals should be connected to protective earth and equipotential bonding should be realized between the earthing terminals of the instruments and SPD01. Equipotential bonding is required to avoid any significant current flow through the instrument cable shield which may cause the instruments to function unreliably (loss of data) or, eventually, to cause damage. Hukx industrial sensors and SPD01 should be connected to the same earth potential and the resistance between these two connections points should be minimized, ideally the resistance should not exceed 1Ω . Proper earthing can only be realized through the earthing terminal. The instrument feet or any of the mounting screw holes should not be relied upon for earthing of the instrument body.



Figure 5.4.3.1 Hukx industrial instrument earthing terminal.

Earthing of exposed metal parts of an electrical installation is required by many local safety regulations to ensure that the installation is safe to work on for supporting personnel.

⚠ WARNING

Connect the earthing terminal to earth ground to guarantee personal safety.

When a Hukx industrial pyranometer is directly connected to a SCADA system, the earthing terminal of the pyranometer should be connected to earth as well as the earth ground of the SCADA system to realize equipotential bonding.

5.4.4 Electrical isolation

Hukx industrial sensors may be safely installed directly onto a PV array. The electrical potential of the array support structure may be affected by, for example, fault currents and lightning strokes. Therefore, special care should be taken to protect devices from potential differences that may be present in different parts of the entire PV system. When installing the SRD100-D1 on the PV array structure they should preferably be electrically isolated from the PV array structure. This can be realized using the Pyranometer Isolation Disk (PID01), see the list of accessories in Section 3.6. Earthing of the instrument body must then be realized through the earthing terminal which should be connected to protective earth and to the earthing terminal of an SPD when present. This allows instrument installation onto the PV array without detailed knowledge of the PV plant grounding structure.



Figure 5.4.4.1 SRD100-D1 with PID01 to be used for on-array installation.

5.4.5 RS-485 network

Hukx industrial sensors are used in a two-wire (half-duplex) RS-485 network. In such a network the instrument acts as a server device and responds to data requests from the client device. An RS-485 network (or bus) consists of a wire pair for data transmission and a signal ground wire. The three conductors are:

- RS-485 data[+], B' or B (non-inverted lines)
- RS-485 data[-], A' or A (inverted line)
- RS-485 signal ground

RS-485 uses differential signaling for data transmission. This means that the logic states are encoded in the electrical potential difference between the data[+] and data[-] lines, whereas on a single-ended interface it would be encoded in the potential of the data line with respect to the signal ground. For RS-485, the signal ground is required to provide a reference for the common mode reference potential, common to the data[+] and data[-] lines. When designed and installed correctly, RS-485 provides a robust reliable communication channel in electrically noisy environments.

The RS-485 interface of the SRD100-D1 is internally isolated from the internal electronics as well as from the instrument body, see the Figure below. Both isolation barriers are rated at 1.5 kV.

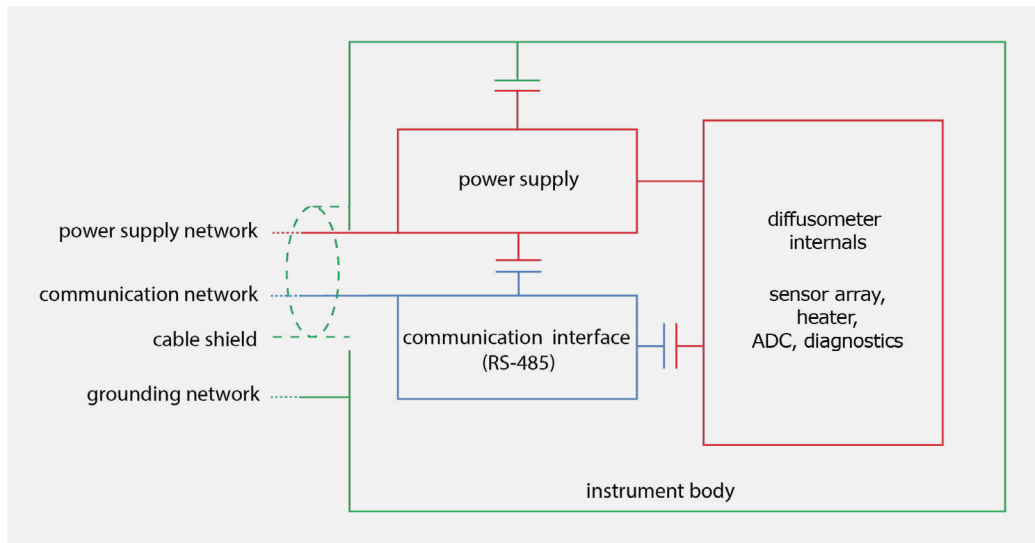

Figure 5.4.5.1 Schematic representation of industrial sensors indicating the electrical connections and the different isolation barriers.

An example of the topology of an RS-485 2-wire network is shown in the below figure. The network has a linear setup with side branches, called stub lines, to the nodes and line termination resistors at each end. Each node in the network is protected by a surge protection device such as the SPD01.

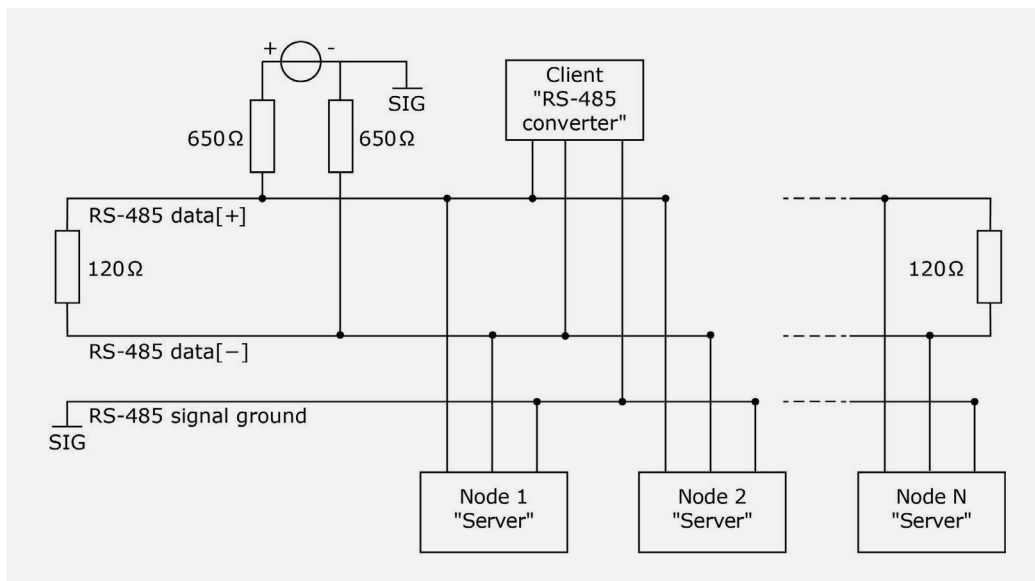

Figure 5.4.5.2 Typical topology of a 2-wire (half-duplex) RS-485 network. This Figure does not show the power supply or any isolators that may be required.

Line termination must be installed at both ends of the bus between the data[+] and data[-] lines. According to the RS-485 standard (EIA-485), termination resistors have a value of 120 Ω and no more and no less than two-line termination resistors should be installed in a single network, see "Modbus over serial line specification and implementation guide v1.02", Section 3.4.5. Failure to install line termination resistors leads to signal reflections which could compromise signal integrity, especially for large networks. Placing more than two line termination resistors causes excessive loads on the RS 485 bus which may compromise signal integrity and may lead to damage to equipment.

NOTICE

Line termination is required at both ends of the bus between the data[+] and data[-] lines. Two, and no more and no less, than two termination resistors should be placed.

A so-called fail-safe biasing or line polarization circuit should be installed to keep the data lines in a well-defined state when not being driven by any transmitter, see "Modbus over serial line specification and implementation guide v1.02", section 3.4.6. To do so, pull-up and pull-down resistors have to be installed on the data[+] and data[-] lines, respectively, as shown in figure 5.4.5.2. Typical values for both resistors are in the range of 650 to 850 Ω . On the data[+] line this resistor is connected to a +5 VDC supply which is referenced to the signal ground and on the data[-] line to the signal ground. This will keep the data lines in a well-defined state when none of the connected devices is controlling the bus. Failure to install a fail-safe biasing circuit leaves the receivers susceptible to noise and may cause Modbus communication with the instrument to fail.

NOTICE

A fail-safe biasing (line polarization) circuit should be installed.

The maximum allowable stub length depends on the data rate, but in general it should be kept as short as possible to avoid signal reflection in these un-terminated line elements. The lower the data rate of the serial communication, the longer any stub lines may be without causing problems, see "Modbus over serial line specification and implementation guide v1.02", Section 3.4.3. Never use stub lines longer than 20 meters.

NOTICE

Do not use stub lines (derivations) longer than 20 m.

5.5 Electrical connections

This section provides an overview of the electrical connections of Hukx industrial sensors, when using the factory-supplied cable.

5.5.1 Wiring and connections

To use the SRD100-D1, the instrument must be connected to a power supply and an RS-485 network via the M12-A connector. Table 5.3.1.1 shows the electrical connections with the insulation colours used in the cable that is part of the delivery.

Table 5.5.1 Cable and connector connections of Hukx industrial pyranometers. Pin numbering as indicated in the figure below.

PIN*	conductor insulation color	function
1	brown	VDC [+]
4	black	VDC [-]
3	blue	RS-485 signal ground
2	white	RS-485 data[+], B' or B
5	gray	RS-485 data[-], A' or A
-	yellow	cable shield / instrument body

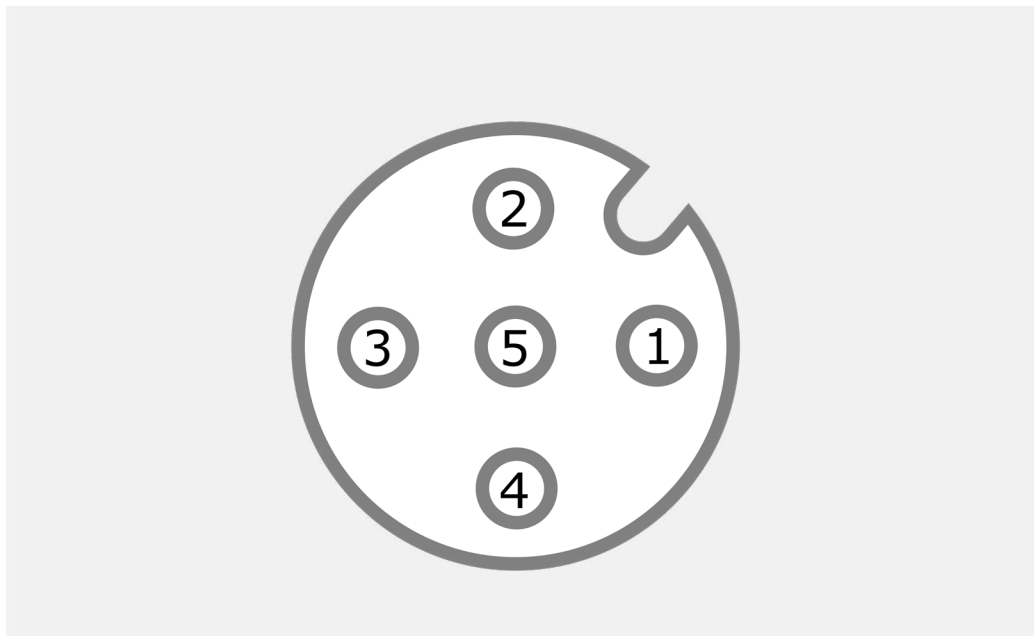

Figure 5.5.1 Schematic of the M12-A connector layout of Hukx industrial pyranometers, indicating the PIN numbers.

5.5.2 Earth connection

For safe and reliable use of the instrument, the earthing terminal is used to connect the instrument body to earth ground, see Section 5.4.3. The conductive instrument body is in turn connected to the connector body which provides an earth connection for the cable shield.

5.5.3 Connection to a PC

Configuration of Hukx industrial sensors is most easily done with the instruments connected to a PC and using the Hukseflux Sensor Manager software.

This software provides a user-friendly way to connect to the instrument and to adjust the communication settings, even without knowledge of the current configuration settings, using the dedicated auto-connect feature. Alternatively, another Modbus communication tool can be used. For more details about programming, consult the separate "Hukx programming manual industrial pyranometers and diffusometer" and the "register list" for your instrument model.

To connect to a PC many RS-485 converters are available. Two recommended and tested RS-485 converter models are:

- Advantech, Adam-4561, 1-port Isolated USB to RS-232/422/485 Converter
- Moxa, Uport 1150I, 1-port RS-232/422/485 USB-to-serial converters with optical isolation protection

NOTICE

When using the popular RS-485 converter solutions manufactured by the FTDI company, e.g. model USB-RS485-WE-1800-BT using the FT232R chipset, use so-called fail-safe biasing resistors as the idle state of these converters is undefined and is likely to cause communication problems.

In particular, when using an isolated converter the signal ground must be connected to the VDC[-] wire to get a reliably functioning connection to the PC.

5.6 Setting up Modbus RTU communication

Hukx industrial sensors function as Modbus RTU servers. The instruments must be used in conjunction with a client device, such as a PC or data logger. The server device responds to requests sent by the client device.

This section provides a brief overview of how to retrieve the most important Modbus registers: the temperature compensated irradiance and the instrument temperature through the Modbus interface. For an in-depth description of the Modbus interface of the Hukx industrial sensors, including an overview of supported function codes, data types and example code, consult the "Hukx programming manual industrial pyranometers and diffusometer". There is a register list for every product model. These can be downloaded via <https://hukx.com/downloads>. For general information regarding the Modbus protocol, consult the "Modbus Application Protocol Specification" and the "Modbus over Serial Line Specification and Implementation Guide", available from Modbus Organization.

5.6.1 Reading the irradiance

The temperature compensated diffuse irradiance can be read using Modbus function codes 0x03 (read holding register) or 0x04 (read input register). In addition to reading the temperature compensated diffuse irradiance it is recommended to read at least the "high internal humidity indicator" at regular intervals.

Modbus registers

register address (HEX)	parameter	description	data type
0x0200	temperature compensated irradiance	the temperature compensated irradiance in W/m ²	float
0x0684	internal high humidity indicator	alert for high internal humidity	bool

5.7 Programming, register structure

For more details about programming, consult the separate "Hukx industrial pyranometer programming manual" and the "register list" for your sensor model. The latest version of these documents can be downloaded via <https://hukx.com/downloads>

6 Instrument diagnostics

The SRD100-D1 provides various possibilities to perform instrument diagnostics. Read the following section to see which diagnostic features are supported.

Remote diagnostic sensors inside the instruments allow early detection of potential problems and, if followed by appropriate action, can help to prevent loss of data or damage to the instrument. Most remote diagnostic signals are a combination of sensor readings and alerts showing whether the value is within an acceptable range or not. It is recommended to read and store the alert indicators at regular intervals. Storing the corresponding sensor signals is also required for a more detailed diagnosis. Whenever an indicator flag is set by the instrument, setting of an alert, it is recommended to collect and review the underlying sensor data of the past year. Historic sensor data helps experts in taking appropriate actions to solve the problem.

A detailed description of how to read the Modbus registers for instrument diagnostics can be found in the separate "Hukx programming manual industrial pyranometers and diffusometers" and in the "register list" for your product model. The latest version of these documents can be downloaded via <https://hukx.com/downloads>

Table 6.1 Copy of the table in the specification overview.

Instrument diagnostics	
remote diagnostics alerts	
high internal humidity	•
heating malfunction	•
remote diagnostics measurements	
instrument body temperature	•
internal humidity	•
heater current	•

6.1 Instrument temperature

Measurands for diagnostics

measurand	instrument body temperature
instrument body temperature measurement accuracy	$\pm 1.0 \text{ }^\circ\text{C}$

Check the sensor temperature against the dewpoint or ambient air temperature. During daytime, the instrument temperature is normally higher than ambient temperature. Solar radiation will heat up the instrument potentially by 10 °C.

At night, the instrument temperature is normally lower than ambient air temperature. Infrared radiation loss from the sky causes the instrument to cool, potentially to temperatures below dewpoint. The internal heating may keep the instrument permanently above dewpoint.

The sensor temperature should preferably be higher than the ambient temperature and dewpoint. Whenever the sensor body temperature is below the dewpoint, water condensation may form on the outer surface of the diffusometer, including the outer dome, which can affect the irradiance measurement.

6.2 Internal relative humidity

Measurands for diagnostics

alert	high internal humidity flag
behavior	triggers when internal humidity exceeds 40 %
measurand	sensor internal relative humidity
relative humidity sensor accuracy	$\pm 3 \% \text{ RH}^*$

* below 0 °C the humidity sensor output will always be 0 % RH.

Instruments are manufactured and supplied with an internal bag of desiccant. For new instruments, the internal relative humidity will be below 10 % RH at room temperature. Over time, by diffusion through the instrument sealing, the internal relative humidity levels will increase. When a diffusometer accumulates too much moisture, water condensation inside the instrument may cause incorrect measurements and will eventually damage the instrument's electronics. It is therefore recommended to monitor the internal relative humidity and the corresponding alert via the high internal humidity indicator register at regular intervals. When the internal relative humidity exceeds the threshold of the high internal humidity, an alert is raised and an indicator flag is set. The threshold is set to the recommended default of 40 % RH. Above this range, the instrument will not function reliably anymore, see the table on "rated operating conditions" in the specification chapter.

In case the 40 % RH limit is attained, review the internal relative humidity and temperature data of the past years.

If humidity changes show a steady gradient over the years, less than 10 % average change of RH per year at comparable temperatures, this is a sign that the instrument is not leaking. As long as we expect—based on extrapolated data—the relative humidity to remain below 60 % RH action is not urgent. Servicing may be postponed, for example to the next calibration. If RH is consistently higher than 60 % we recommend immediate action.

In case of doubt, contact the manufacturer to discuss the data and the appropriate maintenance actions.

In case of condensation of droplets inside the instrument, contact the manufacturer. At the factory it is possible to replace the desiccant, and it may be possible to repair the instrument in case of leaks.

6.3 Internal heating

Measurands for diagnostics

alert	heater undercurrent flag
behavior	triggers when heater current drops below 200 mA
alert	heater overcurrent flag
behaviour	triggers when heater current exceeds 500 mA
measurand	heater state register
measurand	heater current (indicative only)
measurand	heater duty cycle

The heater state register can be used to switch the internal heater on or off while the heater duty cycle register can be used to adjust the heater power in steps of 10 % with a minimum setting of 10 %. In addition, the heater state register can also be used to obtain the current status of the heater (including any error conditions). We recommend to monitor the heater state registers at regular intervals.

When the heater is [ON], a heater current register allows the user to read the heater's (peak) electrical current. The heater current measurement is an indicative, unverified measurement. Using the heater current reading, an estimation of the heater power can be made. The voltage across the heating element is approximately 5.0 Volt, therefore the heater power is given by:

$$P_{\text{heater}} [\text{W}] = 5.0 [\text{V}] \times \text{"heater current"} [\text{A}] \times \text{"heater duty cycle"} [\%] / 100 [\%]$$

Note that even though the power delivered by the heater is the largest contributor, dissipation by the electronic circuitry also contributes to the heating of the instrument. Therefore the overall heat generation will always be larger than just that of the heater.

7 Maintenance and trouble shooting

7.1 Recommended maintenance and quality assurance

The SRD100-D1 can measure reliably at a low level of maintenance in most locations. Unreliable measurements are usually detected as unreasonably large or small measured values. As a general rule, this means that regular visual inspection combined with a critical review of the measured data, preferably checking against other measurements, is the preferred way to attain a reliable measurement.

The IEC 61724-1 standard covering PV system performance monitoring and the WMO manual covering meteorological network operation, have stricter requirements than those in the below table. IEC recommends weekly cleaning and inspection for its Class A systems, and re-calibration of all sensors every 2 years or more frequently if the manufacturer recommends so. WMO recommends daily inspection and cleaning of instruments used in meteorological networks.

Table 7.1.1 Recommended maintenance of SRD100-D1. If possible, the data analysis and cleaning (1 and 2) should be done on a daily basis. (continued on next page)

Minimum recommended pyranometer maintenance

	interval	subject	action
1	1 week	data analysis	<p>Compare measured data to other diffuse or global horizontal (pyranometer) measurements nearby (redundant instruments).</p> <p>In case of use with PV systems, compare daytime measurements to PV system output. Look for any patterns and events that deviate from what is normal or expected.</p> <p>Check the alerts. If any indicator flags are set, then collect the underlying sensor data of the past year for analysis.</p> <p>Check internal relative humidity and heater current according to the recommendations in the chapter about remote diagnostics.</p>
2	2 weeks	cleaning	<p>Use a soft cloth to clean the dome of the instrument, persistent stains can be treated with soapy water or alcohol.</p>
3	6 months	inspection	<p>Inspect the instrument for any damage. Inspect if the connector is properly attached. Inspect cable quality and connection to the instrument:</p> <ul style="list-style-type: none"> – Verify earthing using a multi-meter. – Inspect connection of the shield. – Inspect connection of RS-485 signal ground to the RS-485 interface. – Inspect connection of sensor power supply. – Check the condition of the connectors (on the chassis as well as the cable). <p>If instrument is required to be isolated from mounting platform verify isolation inspect the dome.</p> <p>Check the dome for scratches or damage, see also the appendix on optical surface imperfections. Inspect the interior of the dome for condensation. Inspect mounting position, inspect leveling and tilt angle and adjust if necessary</p>

5	2 years	recalibration	For sensitivity adjustment and writing the calibration history data via a PC using the Hukseflux Sensor Manager software, consult the Hukseflux Sensor Manager manual for instructions typically during calibration desiccant is replaced. Ask the manufacturer for directions
6	5 years	parts replacement	Desiccant replacement (< 5 year interval, typically replaced during calibration, two bags of silica gel, 2 x 1 g) if applicable/necessary, contact our service department to arrange specific parts replacement

7.2 Trouble shooting

Table 7.2.1 Trouble shooting for SRD100-D1 (continued on next pages).

internal high humidity indicator flag set	If the internal high humidity indicator flag is set, the sensor may have a leak, or the desiccant may be saturated. Look at the long-term (at least a year) trends of relative humidity. Contact the manufacturer and send the supporting data file over to discuss servicing options.
Not able to communicate with the sensor.	<p>Check all physical connections to the instrument.</p> <p>Check the cable for broken/damaged wires by measuring the electrical resistance from pins to cable ends. The electrical resistance of every conductor should be < 10 Ω. In case of doubt, try a new cable.</p> <p>Verify the fail-safe biasing networks and bus termination as described in the sections about electrical installation design and the RS-485 network.</p> <p>Verify that all Modbus server devices on the bus have a unique device address.</p> <p>Verify that all devices on the bus are using the same serial communication settings.</p> <p>Verify that the Modbus client application is addressing the Modbus server device using the correct device address.</p> <p>Default settings upon delivery are listed in the section on electrical specifications. if settings are not known use the Hukseflux Sensor Manager.</p> <p>Connect sensor to a PC and perform a search operation with the Sensor Manager to determine the diffusometer's device address and serial communication settings.</p> <p>if all physical connections are correct, and communication with the instrument still cannot be established, contact the manufacturer to discuss servicing options.</p>

The irradiance signal is unrealistically high or low.

Verify that the instrument dome is clean.
Check the location of the diffusometer.
Check the location for obstructions that could explain the measurement result, see the section about site selection.
Verify that the dome protector has been removed, see the section installation and removal of the dome protector.
Check the orientation/leveling of the diffusometer.
Check if the irradiance signal responds to light: expose the sensor to a strong light source, for instance a 100 W light bulb at 0.1 m distance. Darken the sensor either by putting something over it or switching off the light. The instrument voltage output should go down and within one minute approach 0 W/m².
Verify that the diffuse irradiance sensitivities programmed into the instrument corresponds to the sensitivity on the calibration certificate. If not, then update the diffuse irradiance sensitivities to the correct value, see the section on adjusting diffuse irradiance sensitivities. check that the correct Modbus registers are being read.
Consult the "Hukx programming manual industrial pyranometers and diffusometers".
Verify that the two diffuse irradiance registers (value is composed of the content of 2 registers) are being read in a single Modbus request.
Check the data acquisition by replacing the sensor with a spare instrument with the same Modbus device address.

The instrument signal shows unexpected variations.

Check the presence of strong sources of electromagnetic radiation (radar, radio).
Inspect the measurement location for potential sources of signal variation.
Inspect instrument power supply.
Check the condition and connection of the shield.
Check the condition of the instrument cable.
Check if the cable is not moving during the measurement.
Check the condition of the connectors (on the chassis as well as the cable)

The dome shows internal condensation.

Contact the manufacturer to discuss servicing options.

Options are as follows:

In case there is a minor layer of moisture that is hardly visible, you may consider to replace the desiccant and wait a few days to see if the situation improves.

Ask the manufacturer for detailed instructions.

in case of condensation of droplets in the instruments:

the instrument sensor and electronics may have been affected. Both can no longer be considered reliable. The factory may perform sensor diagnostics and make a quotation for repair. It may be possible to disassemble the instrument, replace parts and test and calibrate the repaired instrument.

7.3 Calibration and validation

7.3.1 Indoor calibration in a laboratory

Hukx's recommendation for re-calibration is to perform calibration indoor by comparison to an identical reference instrument, following the procedure described in ISO 9847:2023 type A2.

For more information on why indoor calibration is preferred over outdoor calibration, see the following paragraph on outdoor testing and also our application note "why indoor calibration is preferable".

The recommended calibration interval of the diffusometer is 2 years. The registers containing the applied sensitivities and the calibration history of the SRD100-D1 are accessible for users. This allows the user to choose his own local calibration service.

Calibration is done with a reference diffusometer in a controlled indoor environment. The applicable standard is ISO 9847 "*International Standard—Solar Energy—Calibration of field pyranometers by comparison to a reference pyranometer*".

At Hukx, an indoor calibration, according to the same standard, is used.

7.3.2 Outdoor validation and calibration using a reference diffusometer

Hukx does not recommend to attempt an outdoor calibration of the SRD100-D1.

Note that the SRD100-D1 diffuse radiation output is based on a sensor array, with their individual calibration. Of these sensors, only 1 is active in providing the diffuse radiation output at any time. This means that any outdoor validation is complicated, and should be performed with care.

Hukx recommends to perform field validation following the procedure described in ISO 9847:2023 type B1, to a spectrally flat Class A pyranometer mounted a solar tracker under a shadow ball.

For the validation, take care to limit the validation to cloudless clear sky days, where the diffuse radiation spectrum is equivalent to the ASTM G173-03 diffuse horizontal irradiance spectrum. We state that a diffuse radiation spectrum is equivalent to the ASTM G173-03 diffuse horizontal irradiance spectrum, if the spectral correction factor is between 0.95 and 1.05. See the appendix on diffuse irradiance spectra for details and the definition of the spectral correction factor.

Under these conditions, the diffuse radiation should be within $\pm 10\%$ of the reference irradiance readings.

Any full validation of all sensors should be conducted over a sufficient duration to ensure that each sensor has a significant dataset reporting the actual diffuse radiation. To identify which sensor is reporting the actual diffuse radiation, read out the 'active sensor row number' and 'active sensor column number' registers, or the individual temperature compensated diffuse irradiance estimators.

7.4 Spare parts

- set of 2 adjustable leveling feet and 1 static foot (order number LF01)
- set of 3 static feet (order number SF01)
- cable for SRD100-D1, with female M12-A connector at sensor end, conductors stripped over 0.15 m with ferrules
- leveling mount, for spring-loaded leveling and mounting on a surface (order number LM01)
- tube leveling mount, for spring-loaded leveling and mounting on a tube, includes LM01 (order number TLM01)
- lower clamp for tube mount
- pair of M5x30 bolts for tube mount
- pair of M5x45 bolts for tube mount
- set of 5 dome protectors
- uninsulated ring terminal with earthing screw
- bag of silica gel, 1 g

7.5 Repair services

The dome, mask, bubble level, sensors and other internal sensors of the SRD100-D1 cannot be supplied as spare parts. In case of damage to the diffusometer, the instrument must be tested after repair to verify that its performance is within specification limits.

Validation is a test to verify that the instrument is fit for purpose. No certificates or test reports are issued.

Calibration includes a validation, and a certificate is issued.

Table 7.5.1 Required testing of SR300-D1 as a function of the most common repair services.

Servicing SR100-D1				
	dome replacement	PCB replacement	sensor replacement	o-ring / connector / bubble level replacement
validation (no report issued)	-	-	-	•
calibration (including validation)	•	•	•	-

7.6 Scratches on domes; optical surface imperfections

Hukx has in-house test procedures to verify if surface imperfections (scratches and digs) on the pyranometer domes are permissible or not. The procedures essentially check if, with a certain scratch the pyranometer perform as required.

In in-house testing, the requirements, procedures and specifications are according to ISO 10110 "Optics and photonics: Preparation of drawings for optical elements and systems". ISO 10110-7 "specifies the indication of the level of acceptability of surface imperfections within a test region on individual optical elements and optical assemblies. These include localized surface imperfections, edge chips and long scratches".

We assume that the main risk is damage to the outer surface of the dome. Therefore only this surface is checked. We assume other surfaces do not require inspection.

7.6.1 Inspection of new instruments

For new instruments: consult the ISO 10110 standard. Contact the manufacturer in case surface imperfections on the outer surface of the outer dome exceed ISO 10110: 5/4 x 0.063, while ignoring 0.04 and smaller.

7.6.2 Inspection of used instruments

For used instruments, there may in the course of time be additional imperfections.

The questions then are:

- Did the sensitivity significantly change?
- Did the directional response significantly change?

The dome quality of diffuse radiation measuring instruments is not as important as that of pyranometers. Some scratching is permissible.

The following is a brief and very simplified procedure that can be followed by a user:

1. Mark the scratches on the outer surface of the outer dome. Not those on the inner surface of the outer dome.
2. Make a photograph of the imperfection with a 1 mm scale next to it for comparison, preferably in a dark environment with a single-point light source, illuminating the imperfection. Enlarge the picture and make an "on-screen" estimate of the size. Ideally a test should be done using a DIN ISO 10110-7 tool.
3. Estimate the approximate length L in [mm] and width W in [mm] of the scratch. Multiply $L \times W$. You may also send such pictures to the supplier to get a second opinion.
4. Grade each of the scratches into one of the following categories:
 - A = [larger than 0.026 mm²] or using ISO 10110-7 tool [grade 0.16],
 - B = [between 0.026 mm² and 0.01 mm²] or using ISO 10110-7 tool [grade 0.10],
 - C = [between 0.01 mm² and 0.004 mm²] or using ISO 10110-7 tool [grade 0.063],
 - D = [smaller than 0.004 mm²].

In case of doubt between grades, then choose the smaller grade.

5. Ignore all scratches with categorization C and D.
6. If dome contains 2 or more scratches of category A within a 45° cone from the center of an aperture then [FAIL]
7. If dome contains 4 or more scratches of category B within a 45° cone from the center of an aperture then: [FAIL]
8. else [PASS]

- In case the procedure results in a [FAIL], then the imperfections are clearly too large; dome needs replacement. Send the instrument back to the factory for repair or consider purchasing a new instrument.
- In case the procedure results in a [PASS], then the imperfections are so small they are permitted; they will not have a negative impact on the sensitivity and directional error. Continue using the instrument.

NOTE 1: outer domes of SRD100-D1's can be replaced.

NOTE 2: ISO 10110 tests for surface imperfections are subjective.

8 Appendices

8.1 Appendix on standards for classification and calibration

Both ISO and ASTM have standards on instrument classification and methods of calibration. The World Meteorological Organization (WMO) has largely adopted the ISO classification system.

Table 8.1.1 Pyranometer standardization in ISO and ASTM.

Standards on instrument classification and calibration	
ISO standard	equivalent ASTM standard
ISO 9060:2018 <i>Solar energy—Specification and classification of instruments for measuring hemispherical solar and direct solar radiation</i>	not available Comment: work is in progress on a new ASTM equivalent standard
ISO 9846:1993 <i>Solar energy—Calibration of a pyranometer using a pyrhelimeter</i>	ASTM G167-15 <i>Standard Test Method for Calibration of a Pyranometer Using a Pyrhelimeter</i>
ISO 9847:2023 <i>Solar energy—Calibration of pyranometers by comparison to a reference pyranometer</i>	ASTM E824-10 <i>Standard Test Method for Transfer of Calibration from Reference to Field Radiometers</i> ASTM G207-11 <i>Standard Test Method for Indoor Transfer of Calibration from Reference to Field Pyranometers</i>
ISO 9059:1990 <i>Solar energy—Calibration of field pyrhelimeters by comparison to a reference pyrhelimeter</i>	ASTM E816-15 <i>Standard Test Method for Calibration of Pyrhelimeters by Comparison to Reference Pyrhelimeters</i>

8.2 Appendix on calibration hierarchy

Traceability of diffusometer sensitivities is to SI via the World Radiometric Reference, WRR. WRR is a “consensus standard”.

The distinguishing feature of traceability to WRR is that reference-operating conditions include the spectrum of natural direct solar radiation (source ISO 9847:2023).

WRR is maintained by the World Radiation Center in Davos Switzerland (PMOD / WRC), using a group of instruments called the World Standard Group (WSG). PMOD / WRC is a designated institute of the Swiss Federal Office of Metrology, the Swiss signatory of the CIPM Mutual Recognition Agreement (MRA). PMOD / WRC has an MRA with WMO as well.

The use of WRR is mandatory when working according to the standards of both WMO and ISO. ISO 9874 states under Paragraph 1.3: the methods of calibration specified are traceable to the WRR. The WMO manual states under Paragraph 7.1.2.2: the WRR is accepted as representing the physical units of total irradiance.

See www.pmodwrc.ch

The Hukx factory calibration is traceable to an outdoor WRR calibration.

Table 8.2.1 Calibration hierarchy for SRD100-D1.

NREL transfer standard group calibration

The NREL Transfer Standard Group (TSG) is calibrated directly to the World Standard Group (WSG) during the International Pyrheliometer Comparisons (IPC), and thus to WRR.

NREL absolute cavity radiometer calibration

The reference standard NREL Eppley Absolute Cavity Radiometer is calibrated directly to the NREL Transfer Standard Group (TSG) during the NREL Pyrheliometer Comparisons (NPC).

SR25 reference diffuse radiation calibration

Two diffuse radiation sensors, spectrally flat class A pyranometers, model Hukx SR25, are calibrated to the working standard NREL Eppley Absolute Cavity Radiometer using a Shade/Unshade method described in NREL/TP-100-68999

SR25 working standard diffuse radiation calibration

A spectrally flat class A pyranometer, model Hukx SR25, is calibrated using the NREL BORCAL-P00-Calibration and QA procedure to the reference NREL Eppley Absolute Cavity Radiometer and the two SR25 reference diffuse radiation sensors.

SRD100-D1 working standard outdoor calibration

SRD100-D1 working standards are calibrated by an in-house developed method conform ISO 9847:2023 type B1. This method relies on an outdoor comparison of the SRD100-D1 working standard to the SR25 diffuse radiation working standard mounted on a solar tracker under a shading ball.

Calibration conditions are filtered using the following criteria:

ASTM G173-03 equivalent diffuse horizontal irradiance spectrum, $DNI > 120 \text{ W/m}^2$,
stable sky conditions, solar elevation $> 30^\circ$

Indoor product calibration

calibration of SRD100-D1

method: Hukx Diffuse Radiation Calibration, ISO 9847:2023 type A2

Calibration uncertainty evaluation

The calibration uncertainty has been determined in accordance with EA-4/02 as the square root of the sum of the squares of the calibration uncertainty of the working standard, the uncertainty of the method and the uncertainty due to deviations from the reference conditions. This result can be found on the calibration certificate.

8.3 Appendix on expected change of the WRR scale

The WRR has been accepted since 1980 as representing the physical units of solar irradiance.

WRR contains a systematic error relative to SI. Therefore, the WRR scale will be changed, likely by 0.34 %.

The WRR scale was too high, which means that all irradiance measured with traceability to WRR must be corrected to lower values in $[W/m^2]$.

With the correction from WRR to the new scale, the sensitivities of instruments in $[V/(W/m^2)]$ will go up by 0.34 %.

WMO does not recommend to correct past data. It does, however, recommend to store information about the scale.

Hukx in its latest industrial sensors allows to add metadata, to indicate if calibration is traceable to WRR or to the new scale, to calibration records and to records of calibration history. All these records are stored in the instrument.

A reference for the scale change is:

Fehlmann A., Kopp G., Schmutz W. et al. *Fourth World Radiometric Reference to SI radiometric scale comparison and implications for on-orbit measurements of the total solar irradiance*. Metrologica 49 (2012) p34-38.

8.4 Appendix on meteorological radiation quantities

A diffusometer measures irradiance. The time integrated total is called radiant exposure. In solar energy, radiant exposure is often given in $W \cdot h/m^2$.

Table 8.4.1 Meteorological radiation quantities recommended by WMO (additional symbols by Hukx). POA originates from ASTM and IEC standards.

symbol	description	calculation	units	alternative expression	
E_{\downarrow}	downward irradiance	$E_{\downarrow} = E_{g\downarrow} + E_{l\downarrow}$	W/m^2		
H_{\downarrow}	downward radiant exposure for a specified time interval	$H_{\downarrow} = H_{g\downarrow} + H_{l\downarrow}$	J/m^2 or $W \cdot h/m^2$		
E_{\uparrow}	upward irradiance	$E_{\uparrow} = E_{g\uparrow} + E_{l\uparrow}$	W/m^2		
H_{\uparrow}	upward radiant exposure for a specified time interval	$H_{\uparrow} = H_{g\uparrow} + H_{l\uparrow}$	J/m^2 or $W \cdot h/m^2$		
E	direct solar irradiance normal to the apparent solar zenith angle		W/m^2	DNI	Direct Normal Irradiance
E_0	solar constant		W/m^2		
$E_{g\downarrow h}$	global irradiance—hemispherical irradiance on a specified, in this case horizontal surface.*	$E_{g\downarrow} = E \cdot \cos \theta_h + E_{d\downarrow}$	W/m^2	GHI	Global Horizontal Irradiance
$E_{g\downarrow t}$	global irradiance—hemispherical irradiance on a specified, in this case tilted surface.*	$E_{g\downarrow} = E \cdot \cos \theta_t + E_{d\downarrow t} + E_{r\uparrow t}^{***}$	W/m^2	POA	Plane of Array irradiance
$E_{d\downarrow}$	downward diffuse solar radiation		W/m^2	DHI	Diffuse Horizontal Irradiance
$E_{l\uparrow}, E_{l\downarrow}$	upward/downward long-wave irradiance		W/m^2		
$E_r\uparrow$	reflected solar irradiance		W/m^2		
E^*	net irradiance	$E^* = E_{\downarrow} - E_{\uparrow}$	W/m^2		
T_{\downarrow}	apparent surface temperature**		$^{\circ}C$ or K		
T_{\uparrow}	apparent sky temperature***		$^{\circ}C$ or K		
SD	sunshine duration		h		

θ is the apparent solar zenith angle θ_h relative to horizontal, θ_t relative to a tilted surface
 g = global, l = long wave, t = tilted *, h = horizontal*

* distinction horizontal and tilted from Hukx,
 ** T symbols introduced by Hukx,
 *** contributions of $E_{d\downarrow t}$ and $E_{r\uparrow t}$ are $E_{d\downarrow}$ and $E_{r\uparrow}$ both corrected for the tilt angle of the surface

8.5 Appendix on the definition of diffusometer specifications

Table 8.5.1 Definition of diffusometer specifications.

specification	definition	source
response time (95 %)	Time for 95 % response. The time interval between the instant when a stimulus is subjected to a specified abrupt change and the instant when the response reaches and remains within specified limits around its final steady value. The response time is a measure of the thermal inertia inherent in the stabilization period for a final reading.	ISO 9060:2018 WMO 1.6.3
zero offset a (200 W/m ² net thermal radiation)	Response to 200 W/m ² net thermal radiation (ventilated). zero offsets are a measure of the stability of the zero-point.	ISO 9060:2018
zero offset b (5 K/h in ambient temperature)	Response to 5 K/h change in ambient temperature. Zero offsets are a measure of the stability of the zero-point. Offsets due to rapid temperature changes by cold rain showers are excluded from zero offset b.	ISO 9060:2018
zero offset c	Total zero offset including the effects of zero offset a and b and other sources.	ISO 9060:2018
non-stability (change per year)	Percentage change in sensitivity per year. The dependence of sensitivity resulting from ageing effects which is a measure of the long-term stability.	ISO 9060:2018
non-linearity (50 to 1000 W/m ²)	Percentage deviation from the sensitivity at 100 W/m ² due to the change in irradiance within the range of 50 W/m ² to 1000 W/m ² .	ISO 9060:2018
temperature response (interval of 80 °C)	Percentage deviation of the sensitivity due to change in ambient temperature within the interval of -30 °C to +50 °C relative to 20 °C.	ISO 9060:2018
tilt response (0° to 180° at 100 W/m ²)	Percentage deviation from the sensitivity at 0° tilt (horizontal) due to a change in tilt from 0° to 180° at 100 W/m ² irradiance. Tilt response describes changes in the sensitivity due to changes of the tilt angle of the receiving surface.	ISO 9060:2018
additional signal processing errors	The additional signal processing errors contain data acquisition and analogue to digital conversion that might be carried out in the instrument and all other processing steps carried out within the instrument that are not covered by the other specifications.	ISO 9060:2018

sensitivity	The change in the response of a measuring instrument divided by the corresponding change in the stimulus.	WMO 1.6.3
spectral range	The spectral range of radiation to which the instrument is sensitive.	Hukx

8.6 Appendix on terminology/glossary

Table 8.6.1 Definitions and references of used terms (continued on next pages).

term	definition (reference)
solar energy or solar radiation	Solar energy is the electromagnetic energy emitted by the sun. Solar energy is also called solar radiation and shortwave radiation. The solar radiation incident on the top of the terrestrial atmosphere is called extra-terrestrial solar radiation; 97 % of which is confined to the spectral range of $(290 \text{ to } 3\,000) \times 10^{-9} \text{ m}$. Part of the extra-terrestrial solar radiation penetrates the atmosphere and directly reaches the earth's surface, while part of it is scattered and/or absorbed by the gas molecules, aerosol particles, cloud droplets and cloud crystals in the atmosphere. The former is the direct component, the latter is the diffuse component of the solar radiation. (ref: WMO, Hukx)
hemispherical solar radiation	Solar radiation received by a plane surface from a 180° field of view angle (solid angle of $2\pi \text{ sr}$). (ref: ISO 9060)
global solar radiation	Also GHI: the solar radiation received from a 180° field of view angle on a horizontal surface is referred to as global radiation. Also called GHI. This includes radiation received directly from the solid angle of the sun's disc, as well as diffuse sky radiation that has been scattered in traversing the atmosphere. (ref: WMO) Hemispherical solar radiation received by a horizontal plane surface. (ref: ISO 9060)
direct solar radiation	Radiation received from a small solid angle centered on the sun's disc, on a given plane. (ref: ISO 9060)
Direct Normal Irradiance	Also DNI: radiation received from a small solid angle centered on the sun's disc, on a plane normal to its direction. (ref: ISO 9060)
diffuse solar radiation	hemispherical radiation minus coplanar direct radiation (ref: ISO 9060)
Diffuse Horizontal Irradiance	Also DHI: global horizontal irradiance minus coplanar direct radiation (the portion emanating from the solar disk and from the circumsolar region of the sky within a subtended full angle of 5°). (ref: IEC 61724-1)

Plane of Array irradiance	Also POA: hemispherical solar irradiance in the plane of a PV array. Sum of direct, diffuse, and ground-reflected irradiance incident upon the frontside of an inclined surface parallel to the plane of the modules in the PV array (ref: ASTM E2848-11 / IEC 61724)
reflected irradiance	Ground-reflected irradiance incident upon a defined surface, typically parallel to the plane of the modules in the (bifacial) PV array.
rearside Plane of Array irradiance	Also POA ^{rear} : sum of direct, diffuse, and ground-reflected irradiance incident on the back side of an inclined surface parallel to the plane of the modules in the PV array. (ref: IEC 61724, ISO TR 9901)
Reflected Horizontal Irradiance	Also RHI: ground-reflected irradiance incident upon a surface, oriented horizontally facing down. (ref: IEC 61724, ISO TR 9901)
terrestrial or longwave radiation	Radiation not of solar origin, but of terrestrial and atmospheric origin and having longer wavelengths (3 000 to 100 000) x 10 ⁻⁹ m). In case of downwelling E _l ↓ also the background radiation from the universe is involved, passing through the "atmospheric window". In case of upwelling E _l ↑, composed of long-wave electromagnetic energy emitted by the earth's surface and by the gases, aerosols and clouds of the atmosphere; it is also partly absorbed within the atmosphere. For a temperature of 300 K, 99.99 % of the power of the terrestrial radiation has a wavelength longer than 3 000 x 10 ⁻⁹ m and about 99 per cent longer than 5 000 x 10 ⁻⁹ m. For lower temperatures, the spectrum shifts to longer wavelengths. (ref: WMO)
World Radiometric Reference (WRR)	Measurement standard representing the SI unit of irradiance with an uncertainty of less than ± 0.3 % (see the WMO Guide to Meteorological Instruments and Methods of Observation, 1983, subclause 9.1.3). The reference was adopted by the World Meteorological Organization (WMO) and has been in effect since 1 July 1980. (ref: ISO 9060)
albedo	Ratio of reflected and incoming solar radiation. Dimensionless number that varies between 0 and 1. Typical albedo values are: < 0.1 for water, from 0.1 for wet soils to 0.5 for dry sand, from 0.1 to 0.4 for vegetation, up to 0.9 for fresh snow.

angle of incidence	Angle of radiation relative to the sensor measured from normal incidence (varies from 0 ° to 90 °).
zenith angle	Angle of incidence of radiation, relative to zenith. Equals angle of incidence for horizontally mounted instruments
azimuth angle	Angle of incidence of radiation, projected in the plane of the sensor surface. Varies from 0 ° to 360 °. 0 is by definition the cable exit direction, also called north, east is + 90 °. (ASTM G113-09)
sunshine duration	Sunshine duration during a given period is defined as the sum of that sub-period for which the direct solar irradiance exceeds 120 W/m ² . (ref: WMO)

8.7 Appendix on sensor performance

The SRD100-D1 is a practical solution to measure diffuse horizontal irradiance. It is designed for easy integration in industrial PV monitoring systems, and offers a robust monitoring device without moving parts.

SRD100-D1 offers a lower-maintenance solution. However, the achievable accuracy is lower than that of trackers with a shading disk. SRD100-D1 has in common with the trackers with shading disks that measurements are traceable and do not use internal corrections or data-processing.

This is a fundamental difference with technology based on shadow rings. These require a tilt-angle-of-shadowband-dependent correction for the view factor the shadowring. Such corrections are model-based and lead to a larger measurement uncertainty than you would expect based on specifications of a pyranometer without a shadowband. For SRD100-D1 the uncertainty associated with the use its static shadow mask is included in the calibration.

Users that require the highest measurement accuracy diffuse irradiance measurements, should invest in spectrally flat Class A pyranometers mounted on solar trackers under a shadow ball, and set up a regular—daily—cleaning and maintenance schedule.

8.7.1 Spectral response

The SRD100-D1 is a silicon-based instrument. The spectral response of silicon sensors is not flat (see figure 8.7.1.1). Therefore, when using the SRD100-D1 to measure irradiance in [W/m²] as if it were spectrally flat, the sensitivity of the sensors varies with the spectral distribution of the diffuse irradiance. Typically, the sensitivity is lower for clear skies as compared to overcast skies.

The diffusometer is calibrated for the AM1.5 diffuse horizontal irradiance spectrum that is the equivalent of the direct normal and global tilted AM1.5 irradiance spectra described in the ASTM G173-03 and IEC 60904 standards, which are “clear sky” spectra. This means that, when measuring diffuse irradiance with spectra that differ from the reference AM1.5 diffuse horizontal irradiance spectrum, the spectral selectivity of the SRD100-D1 introduces measurement errors. Measurements of SRD100-D1 under overcast skies will include a systematic overestimation of diffuse irradiance.

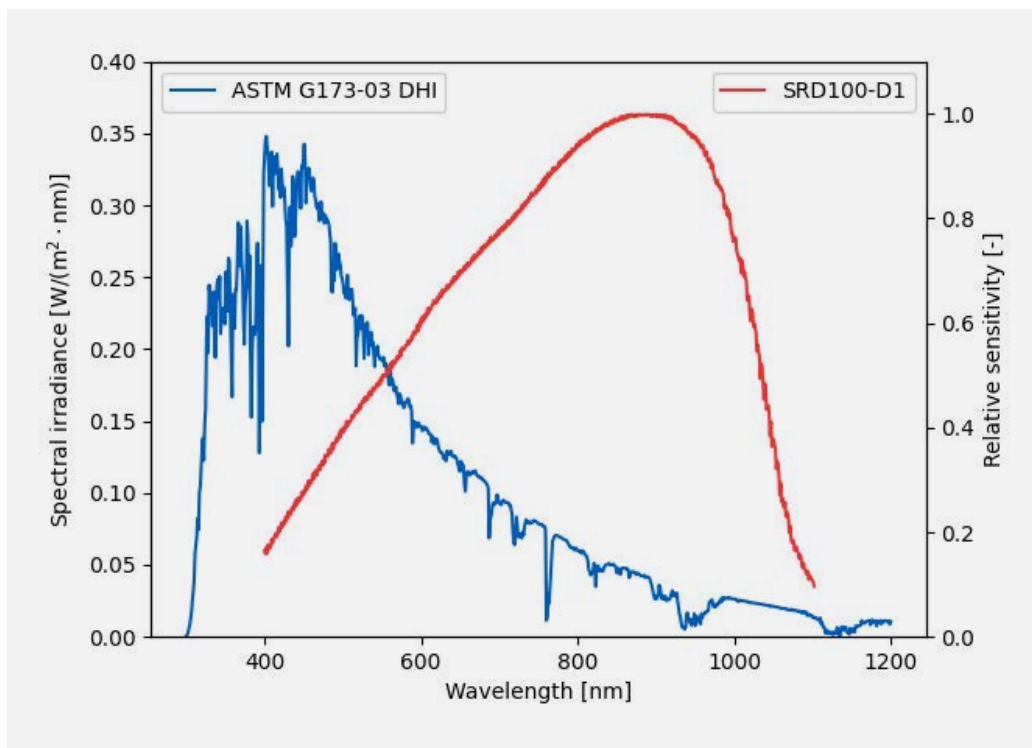

Figure 8.7.1.1 The ASTM G173-03 diffuse horizontal equivalent spectrum and the spectral sensitivity of the SRD100-D1.

For other diffuse irradiance spectra the spectral correction factor C is defined as the sensitivity for that spectrum relative to the sensitivity for the reference spectrum:

$$C = \left[\frac{\int S_{\lambda}(\lambda) E_{\lambda}(\lambda) d\lambda}{\int E_{\lambda}(\lambda) d\lambda} \right] / \left[\frac{\int S_{\lambda}(\lambda) E_{\lambda}^{\text{ref}}(\lambda) d\lambda}{\int E_{\lambda}(\lambda) d\lambda} \right]$$

where S_{λ} is the spectral sensitivity of the SRD100-D1, E_{λ} is the spectral irradiance of the spectrum under consideration, E_{λ}^{ref} is the spectral irradiance of the AM1.5 diffuse horizontal irradiance spectrum. Note that to calculate the spectral correction factor it is sufficient to know the relative spectral sensitivity, because the spectral sensitivity appears in both the numerator and the denominator.

8.8 Appendix on sensor performance

The uncertainty of a measurement under outdoor or indoor conditions depends on many factors. It is not possible to give one figure for measurement uncertainty. The work on uncertainty evaluation is a continuous effort. There are several groups around the world participating in standardisation of the method of calculation. The consensus is that measurement uncertainty should be evaluated according to the "Guide to Expression of Uncertainty in Measurement" or GUM.

8.8.1 Estimates of achievable uncertainties

The table below provides estimates of achievable uncertainties. These estimates are based on Hukx own testing in different climates and seasons.

Table 8.8.1.1 Estimates of achievable uncertainties of measurements with the SRD100-D1 used as a diffusometer or used as a spectrally matched diffusometer. The estimates are based on Hukx own testing in different climates and seasons. These estimates do not include uncertainties due to lack of maintenance and due to instrument fouling. The table specifies expanded uncertainties with a coverage factor of 2 and a confidence level of 95 %.

The SRD100-D1 has been calibrated with traceability to clear sky conditions. The accuracy there is best. It is typically used in combination with a pyranometer; so in case of overcast conditions, and if high accuracy is required we recommend users to use the pyranometer as the best available measurement; (switch to pyranometer). Using the SRD100-D1 for a spectrally matched measurement, we assume that all spectral errors reduce to zero. When using the diffusometer for spectrally matched measurements, switching to a pyranometer is not useful.

IMPORTANT NOTE: there is no international consensus on uncertainty evaluation of diffusometer measurements, so this table should not be used as a formal reference.

diffusometer		uncertainty minute totals at solar noon	uncertainty hourly totals at solar noon	uncertainty daily totals
SRD100-D1	clear sky	10 %	10 %	10 %
	partly clouded	15 %	15 %	15 %
	overcast switch to pyranometer	2 %	2 %	2.5 %
diffusometer spectrally matched		uncertainty minute totals at solar noon	uncertainty hourly totals at solar noon	uncertainty daily totals
SRD100-D1	clear sky	10 %	10 %	10 %
	partly clouded	10 %	10 %	10 %
	overcast uncorrected	10 %	10 %	10 %

The SRD100-D1 is calibrated with traceability to clear-sky conditions, ensuring the highest accuracy for blue skies. Measurements under overcast skies will include a systematic overestimation of diffuse irradiance.

These uncertainty estimates are for standard SRD100-D1 measurements, no extra corrections are applied.

The diffusometer is designed to be used in combination with a pyranometer to measure the global horizontal irradiance. Combining these measurements can reduce uncertainty in the measurement of diffuse horizontal irradiance.

Spectral errors dominate in the measurement uncertainty of the SRD100-D1. These uncertainty estimates are for the measurement of broadband diffuse horizontal irradiance. When measuring spectrally-matched solar irradiance, these numbers do not apply. Please note that the measurement of spectrally-matched solar irradiance with SRD100-D1 has traceability to a certain diffuse spectrum. This is not the same as the typical spectrum with which PV reference cells are calibrated.

8.9 EU declaration of conformity

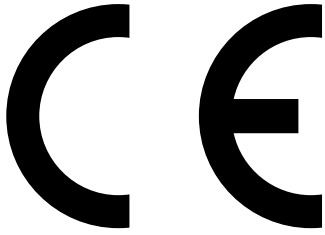

We, **Hukx Thermal Sensors B.V.**,
Delftechpark 31, 2628 XI, Delft,
The Netherlands

hereby declare under our sole responsibility that:

Product models	SRD100-D1
Product type	Diffusometer
Brand name	Hukx

conform with the following directive(s):

2011/65/EU, EU 2015/863	The Restriction of Hazardous Substances Directive
2014/30/EU	The Electromagnetic Compatibility Directive
2006/42/EC	The Machinery Directive

This conformity is declared using the relevant sections and requirements of the following standards,

Hazardous substances	EU RoHS2 (2011/65/EU) and EU 2015/863 amendment known as RoHS3
EMC Emission	EN-IEC 61326-1:2013, EN-IEC 61326-1:2021 (report 230473RPT02)
EMC Immunity	EN-IEC 61326-1:2013, EN-IEC 61326-1:2021, EN-IEC 61000-6-2:2019 (report 230473RPT02)

A handwritten signature in blue ink, appearing to be 'Eric Hoeksema', written over a faint grid background.

Eric HOEKSEMA
Director
Delft, 29 April 2025

About Hukx

Hukx is the leading innovator in solar radiation and heat flux sensor technology. We are proud to set the standard in high-accuracy measurement, and to be working at the heart of the energy transition.

Customers worldwide rely on our bestselling pyranometers and heat flux sensors. From sensor design and selection to supply and recalibration, we support you across the entire lifecycle.

Hukx is headquartered in the Netherlands, with locally owned representative sales offices in the USA, Brazil, India, China, Southeast Asia, and Japan.

Let us help you select the best sensor for your application. Get in touch with our experts today via: info@hukx.com

© Hukx

Version 2505

We reserve the right to change specifications without notice.

www.hukx.com

HUKX