

**HUKX**

Sensor  
Technology

User manual  
Analog component  
net radiometers

**NR01  
RA01**

# Warning statements



Putting more than 12 Volt across the sensor wiring of the main power supply can lead to permanent damage to the sensor.



Do not use "open circuit detection" when measuring the sensor outputs.

# Contents

<b>Introduction</b>	<b>6</b>
<b>1 Ordering and checking at delivery</b>	<b>9</b>
1.1 Ordering NR01	9
1.2 Included items	9
1.3 Quick instrument check	10
<b>2 Instrument principle and theory</b>	<b>12</b>
2.1 General	12
2.2 Pyranometers model SR01	15
2.3 Pyrgeometers model IR01	16
2.4 Typical measurement results	17
2.5 Optional heating	19
<b>3 Specifications of NR01</b>	<b>20</b>
3.1 Specifications of sensors of the NR01	20
3.2 Specifications of pyranometer SR01	25
3.3 Specifications of pyrgeometer IR01	27
3.4 Dimensions of NR01	30
<b>4 Standards and recommended practices for use</b>	<b>31</b>
4.1 Classification standards for pyranometers and pyrrometers	31
4.2 General use for net radiation measurement	32
4.3 General use for sunshine duration measurement	32
4.4 Specific use in meteorology and climatology	33
<b>5 Installation of NR01</b>	<b>34</b>
5.1 Site selection and installation	34
5.2 Installation of the sun screens	35
5.3 Mounting NR01 on a tube	35
5.4 Electrical connection of NR01	36
5.5 Requirements for data acquisition/amplification	38
<b>6 Making a dependable measurement</b>	<b>39</b>
6.1 The concept of dependability	39
6.2 Reliability of the measurement	40
6.3 Repair and maintenance	41
6.4 Uncertainty evaluation	41
<b>7 Maintenance and trouble shooting</b>	<b>45</b>
7.1 Recommended maintenance and quality assurance	45
7.2 Trouble shooting	47
7.3 Calibration and checks in the field	50
7.4 Data quality assurance	52
<b>8 RA01 2-component radiometer</b>	<b>53</b>
8.1 Introduction RA01	53
8.2 Specifications of RA01	54
8.3 Dimensions of RA01	58
8.4 Electrical connection of RA01	60
<b>9 Appendices</b>	<b>61</b>
9.1 Appendix on cable extension/replacement	61
9.2 Appendix on tools for NR01	62

9.3 Appendix on spare parts for NR01	62
9.4 Appendix on standards for classification and calibration	62
9.5 Appendix on calibration hierarchy	64
9.6 Appendix on meteorological radiation quantities	66
9.7 Appendix on ISO and WMO classification tables	67
9.8 Appendix on definition of pyranometer specifications	69
9.9 Appendix on terminology/glossary	70
9.10 Appendix on older NR01 models	72
9.11 EU declaration of conformity	73

# List of symbols

<b>quantities</b>	<b>symbol</b>	<b>unit</b>
voltage output	U	V
sensitivity	S	V/(W/m <sup>2</sup> )
temperature	T	°C
longwave and solar irradiance	E	W/m <sup>2</sup>
Stefan–Boltzmann constant (5.67 x 10 <sup>-8</sup> )	$\sigma$	W/(m <sup>2</sup> ·K <sup>4</sup> )
sunshine duration	SD	h

(see also appendix 9.6 on meteorological quantities)

## **subscripts**

sky	relating to the atmosphere
surface	relating to the ground surface
ambient	relating to ambient air
body	relating to the instrument body
sensor	relating to the sensor

# Introduction

NR01 is a market-leading 4-component net radiation sensor, primarily used in scientific-grade energy balance and surface flux networks. It offers 4 separate measurements: global and reflected solar radiation (via pyranometers) and downwelling and upwelling longwave radiation (via pyrgeometers), using two upward-facing and two downward-facing sensors. Key advantages include its modular design with two pairs of identical sensors, its use of (WMO compliant) spectrally flat pyranometers, low weight, ease of leveling, and low solar offsets in the longwave measurement. NR01's unique capability to heat the pyrgeometers helps reduce measurement errors caused by dew deposition.

NR01 measures the 4 separate components of the surface radiation balance: global solar radiation (downward), reflected solar radiation (upward), and downwelling and upwelling longwave radiation. The solar radiation sensors are called pyranometers and the longwave sensors are referred to as pyrgeometers.

From these 4 separate components, the net radiation is derived. To calculate sky and surface temperatures, it is necessary to compensate for irradiated heat emitted by the pyrgeometers themselves (Stefan-Boltzmann law). A Pt100 temperature sensor is included in NR01's body for this purpose. Sunshine duration may also be estimated using the WMO-approved pyranometric method.

The solar irradiance is measured by pyranometers model SR01, the longwave radiation is measured by pyrgeometers model IR01.

Figure 01 NR01 4-component net radiometer.



## The best 4-component net radiometer

Since its introduction in 2007, the NR014-component net radiometer has become widely used in monitoring networks. Reasons for its popularity include:

- lowest price point for top-level performance
- heated pyrgeometers for superior nighttime data availability
- “spectrally flat” pyranometers, WMO compliant, which is essential for albedo measurement
- low weight and reduced mounting costs
- modular design with 2 pairs of identical sensors
- easy leveling, servicing, and recalibration

## Compliance to standards: spectrally flat pyranometers

To comply with WMO standards and for accurate reflected solar radiation measurement, it is essential to use spectrally flat pyranometers. Reflected solar radiation has a different spectrum than global solar radiation. NR01 has spectrally flat sensors that can measure both global and reflected solar radiation using the same instrument with the same calibration. By contrast, competing models often apply pyranometers that are not spectrally flat, and typically employ different pyranometers and pyrgeometers for the upfacing and downfacing measurements.

Applicable instrument-classification standards are ISO 9060 and WMO-No. 8 *Guide to Meteorological Instruments and Methods of Observation*.

## Operation

Using the NR01 net radiometer is easy. It directly connects to the most commonly used data logging systems. The irradiance levels (in  $W/m^2$ ) are calculated by dividing the NR01 outputs, small voltages, by the sensitivities of the sensors. Longwave irradiance should be corrected using the instrument body temperature. The sensitivities of all sensors are provided on NR01's product certificate.

The solar irradiance in  $W/m^2$  is calculated by dividing the SR01 output, a small voltage, by the sensitivity. The sensitivity is provided with SR01 on its calibration certificate.

The central measurement equation governing solar radiation measurement with pyranometers is:

$$E = U/S \quad \text{(Formula 0.1)}$$

The longwave irradiance in  $W/m^2$  is calculated by dividing the IR01 output, a small voltage, by the sensitivity and taking into account the irradiated heat by the sensor itself (Stefan-Boltzmann law). The sensitivity is provided with IR01 on its calibration certificate.

The central measurement equation governing longwave measurement with pyrgeometers is:

$$E = U/S + \sigma \cdot (T + 273.15)^4 \quad (\text{Formula 0.2})$$

From the upward and downward solar radiation, it is possible to calculate net solar radiation and albedo or surface reflectance. From all 4 solar and longwave components, the net radiation, sky temperature and surface temperature can be derived.

The instrument should be used in accordance with the recommended practices of ISO, WMO and ASTM.

RA01 (single-sided version of NR01) is a market-leading 2-component radiometer, primarily used in scientific-grade energy balance and surface flux networks. It offers 2 separate measurements of global solar and downward longwave radiation with a pyranometer and a pyrgeometer, respectively. Product features include a modular design, low weight, easy leveling, and low solar offsets in the longwave measurement. RA01's unique capability to heat the pyrgeometer reduces measurement errors caused by dew deposition. When combined with estimates of solar albedo and local surface temperature, this instrument can also be used for estimation of net radiation. The advantages of this approach are cost reduction and independence from local surface properties.

**This manual is written for NR01 4-component net radiometer. For RA01 2-component radiometer please consult the dedicated RA01 chapter.**

Figure 0.2 RA01 2-component radiometer.



### Suggested use

- energy balance studies
- surface flux measurements
- climatological networks

## NR01 benefits

The NR01 net radiometer has a modular design with two pairs of identical sensors. This makes it possible to take the instrument apart, easily replace individual sensors, and recalibrate them by using the same procedure. For this reason, it is often selected for use in large monitoring networks.

In order to prevent condensation on the pyrgeometer windows, the NR01 features internal heating close to the pyrgeometers, keeping the instrument above dew point. Since water blocks longwave radiation, heating will improve the reliability of longwave radiation measurement, especially at night, when the risk of condensation is highest. Solar offsets in longwave radiation measurement are very low. Features like these have made NR01 net radiometers a popular choice for energy balance and surface flux studies.

NR01 is also practical to mount. It is much lighter than competing models and includes a 2-axis leveling assembly. The assembly fits a 1-inch NPS tube (recommended outer diameter:  $33.4 \times 10^{-3}$  m). With the included NR01 shim, it can also be mounted on a  $\frac{3}{4}$  inch NPS tube.

## Reference users

Until 2022, the U.S. National Ecological Observatory Network (**NEON**) was the world's largest network employing 4-component net radiometers. After extensive testing, NEON published a [list of sensors](#). We are proud that model NR01 made it onto this list.

In 2022, the Indian Defence Geo-Informatics Research Establishment (**DGRE**) selected NR01 for its 248-station climate monitoring network in the Himalayas.

The UK Centre for Ecology and Hydrology (**CEH**) also included NR01 in its measurement network.

*NOTE: A sensor being included in a network does not constitute a formal endorsement by the network owner.*

## Options

- longer cable, in multiples of 5 m; cable lengths above 20 m in multiples of 10 m
- 10 k $\Omega$  thermistor instead of Pt100 temperature sensor

## See also

- **RA01** radiometer: a single-sided version of **NR01**. Combined with estimates of albedo and surface temperature, this instrument can also be used to estimate net radiation.
- [other sensors for the FLUXNET community](#)
- [CMF01 mounting fixture](#) for installing NR01 on a mast

# 1 Ordering and checking at delivery

## 1.1 Ordering NR01

The standard configuration of NR01 is with two cables, each of 5 meters.

Common options are:

- Longer cables (in multiples of 5 m). Specify total cable length.  
(Cable lengths above 20 m in multiples of 10 m).
- Internal temperature sensor. This can be either a Pt100 (standard configuration) or a 10 k $\Omega$  thermistor (optional). Specify respectively T1 or T2.

## 1.2 Included items

Arriving at the customer, the delivery should include:

- NR01 4-component net radiometer, including a 2-axis leveling assembly
- cable of the length as ordered
- including 4 sun screens
- 1 x product certificate matching the instrument serial number,  
including 4 x calibration certificate of the sensors
- 1 x hex key (2 mm) for fixation and removal of sun screens
- 1 x shim for optionally mounting NR01 on a  $\frac{3}{4}$  inch NPS tube  
instead of on a 1 inch NPS tube (tubes are not included)

Please store the certificates in a safe place.

## 1.3 Quick instrument check

For checking the instrument see the wiring diagram on the product certificate or in the chapter on electrical connection of this manual.

### 1.3.1 General check

1. Inspect the instrument for any damage.
2. Remove the sun screens, using the hex key (see chapter on installation of the sun screen). Inspect the bubble levels.
3. Check the instrument serial numbers against the certificates supplied with the instrument.
4. Check the leveling assembly for x- and y-axis by unlocking the 4 x hex bolts for leveling adjustment.

### 1.3.2 Check of pyranometers SR01

A quick test of the instrument can be done by using a simple handheld multimeter and a lamp.

1. Check the electrical resistance of the sensor between the minus (-) and plus (+) wire. Use a multimeter at the 200  $\Omega$  range. Measure the sensor resistance first with one polarity, then reverse the polarity. Take the average value. The typical resistance of the wiring is 0.1  $\Omega$ /m. Typical resistance should be the typical sensor resistance of 40 to 60  $\Omega$  plus 1.5  $\Omega$  for the total resistance of two wires (back and forth) of each 5 m. Infinite resistance indicates a broken circuit; zero or a low resistance indicates a short circuit.
2. Check if the sensor reacts to light: put the multimeter at its most sensitive range of DC voltage measurement, typically the 100 x 10<sup>-3</sup> VDC range or lower. Expose the sensor to a strong light source, for instance a 100 W light bulb at 0.1 m distance. The signal should read > 2 x 10<sup>-3</sup> V now. Darken the sensor either by putting something over it or switching off the light. The instrument voltage output should go down and within one minute approach 0 V.

### 1.3.3 Check of pyrgeometers IR01

A quick test of the instrument can be done by using a simple handheld multimeter and a thermal source.

1. Check the electrical resistance of the sensor between the minus (-) and plus (+) wire. Use a multimeter at the 1000  $\Omega$  range. Measure the sensor resistance first with one polarity, then reverse the polarity. Take the average value. The typical resistance of the wiring is 0.1  $\Omega$ /m. Typical resistance should be the typical sensor resistance of 25 to 400  $\Omega$  plus 1.5  $\Omega$  for the total resistance of two wires (back and forth) of each 5 m. Infinite resistance indicates a broken circuit; zero or a low resistance indicates a short circuit.

2. Check if the sensor reacts to heat: put the multimeter at its most sensitive range of DC voltage measurement, typically the  $100 \times 10^{-3}$  VDC range or lower. Make sure that the sensor is at 25 °C or lower. Expose the sensor to a heat source at a short distance from the window of more than 50 °C, for instance a heavy (> 5 kg) painted block of metal, or a painted metal container holding hot water. Face the side of the container to avoid condensation of water on the pyrogeometer window. Stir the water to attain homogeneity. A painted surface will act as a blackbody in the far infrared (FIR), irrespective of the visible color. The signal should read positive and  $> 1 \times 10^{-3}$  V now. In case of using your hand as a heat source, the signal should be significantly lower.

### 1.3.4 Check of the Pt100

1. Check the electrical resistance of the Pt100. The resistance between 2 wires at opposite ends of the Pt100 should be in the 100  $\Omega$  range.
2. Check the electrical resistance of the Pt100. The resistance between 2 wires at the same end of the Pt100 should be in the 10  $\Omega$  range or 0.1  $\Omega$  per meter cable.

### 1.3.5 Check of the heater

1. Check the electrical resistance of the heater. This should be in the 100  $\Omega$  range.

### 1.3.6 Optional check for trouble shooting: short circuit check

1. Check the electrical resistance between the sensor wires of different sensors; this should be higher than  $1 \times 10^6 \Omega$ . Most multimeters cannot measure in this range, so please use the highest range. Also check between sensors and heater and between sensors and Pt100. Check the resistance between sensors and body.

# 2 Instrument principle and theory

## 2.1 General

NR01 is a 4-component net-radiometer, consisting of 2 pyranometers type SR01, 2 pyrgeometers type IR01, a heater, leveling assembly for x- and y-axis and a Pt100 instrument body temperature sensor. The design is fully modular, which is easy for servicing and calibration. This chapter describes the instrument measuring principle and theory.

Pyranometers and pyrgeometers (the latter with additional input of the body temperature measurement) measure the solar and longwave radiation received by a plane surface, in  $W/m^2$ . The most common application of NR01 is measurement of net radiation.

From the 4 individual components measured by NR01, the net radiation and several other measurands are calculated.

The following equations apply.

For terminology: see also the appendix on meteorological radiation quantities.

For the upfacing and downfacing pyranometers, global and reflected solar radiation:

$$E_g \downarrow_h = U/S \quad (\text{Formula 2.1.1})$$

$$E_r \uparrow = U/S \quad (\text{Formula 2.1.2})$$

For the upfacing and downfacing pyrgeometers downward and upward longwave irradiance:

$$E_l \downarrow = U/S + \sigma \cdot (T + 273.15)^4 \quad (\text{Formula 2.1.3})$$

$$E_l \uparrow = U/S + \sigma \cdot (T + 273.15)^4 \quad (\text{Formula 2.1.4})$$

Net radiation and albedo (please note that in the calculation of the net radiation, the instrument temperature measurement is no longer included):

$$E^* = E_{\downarrow} - E_{\uparrow} \quad (\text{Formula 2.1.5})$$

$$= E_{g \downarrow h} - E_r \uparrow + E_l \downarrow - E_l \uparrow$$

$$\text{Albedo} = E_r \uparrow / E_{g \downarrow h} \quad (\text{Formula 2.1.6})$$

Equivalent blackbody temperatures of the surface and sky:

$$T_{\text{surface}} = (E_l \uparrow / \sigma)^{1/4} - 273.15 \quad (\text{Formula 2.1.7})$$

$$T_{\text{sky}} = (E_l \downarrow / \sigma)^{1/4} - 273.15 \quad (\text{Formula 2.1.8})$$

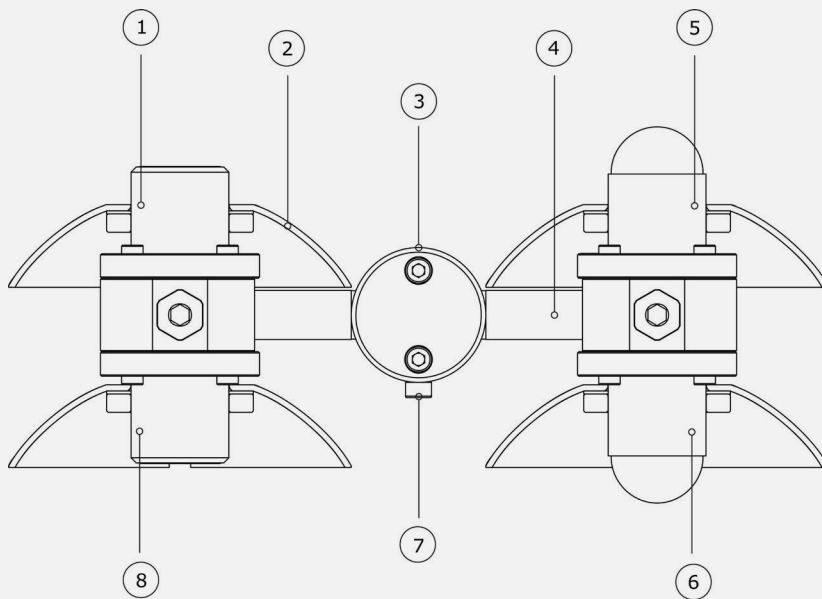
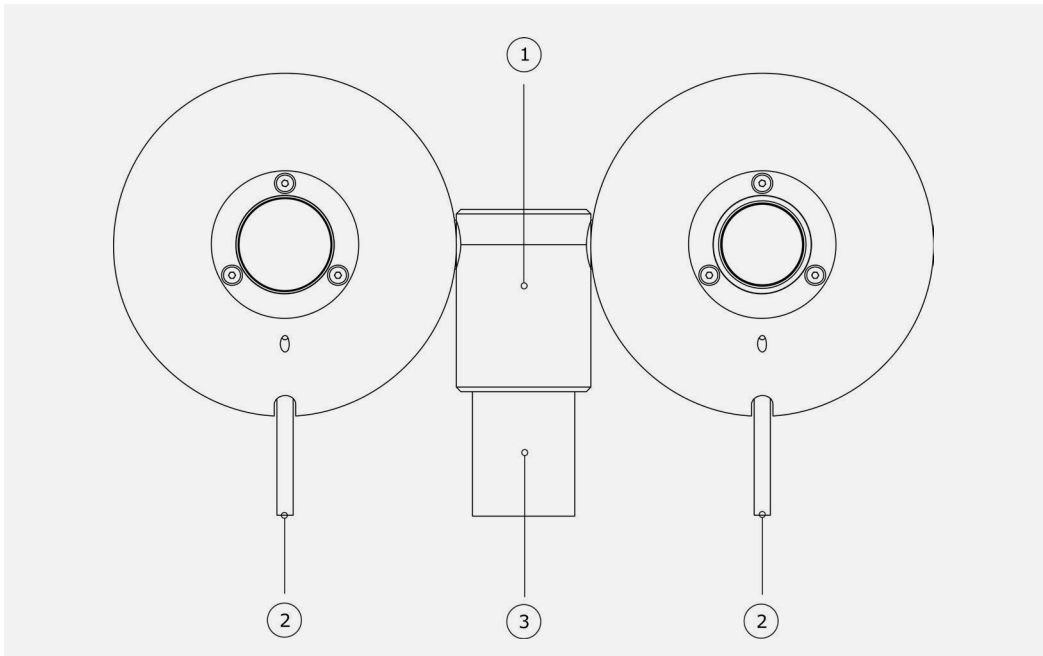

Figure 2.11 Overview of NR01:

1. upfacing pyrgeometer model IR01
2. sun screens
- 3,4. leveling assembly for x- and y-axis
5. upfacing pyranometer model SR01
6. downfacing pyranometer model SR01
7. 4 x hex bolts for leveling adjustment
8. downfacing pyrgeometer model IR01



**Figure 2.1.2** Top view of NR01 fitting a 1 inch NPS tube:

1. leveling assembly for x- and y-axis
2. cable (cable 1 at the left, at pyranometer side, cable 2 at the right, at pyrgeometer side)
3. 1 inch NPS mounting tube (not included)

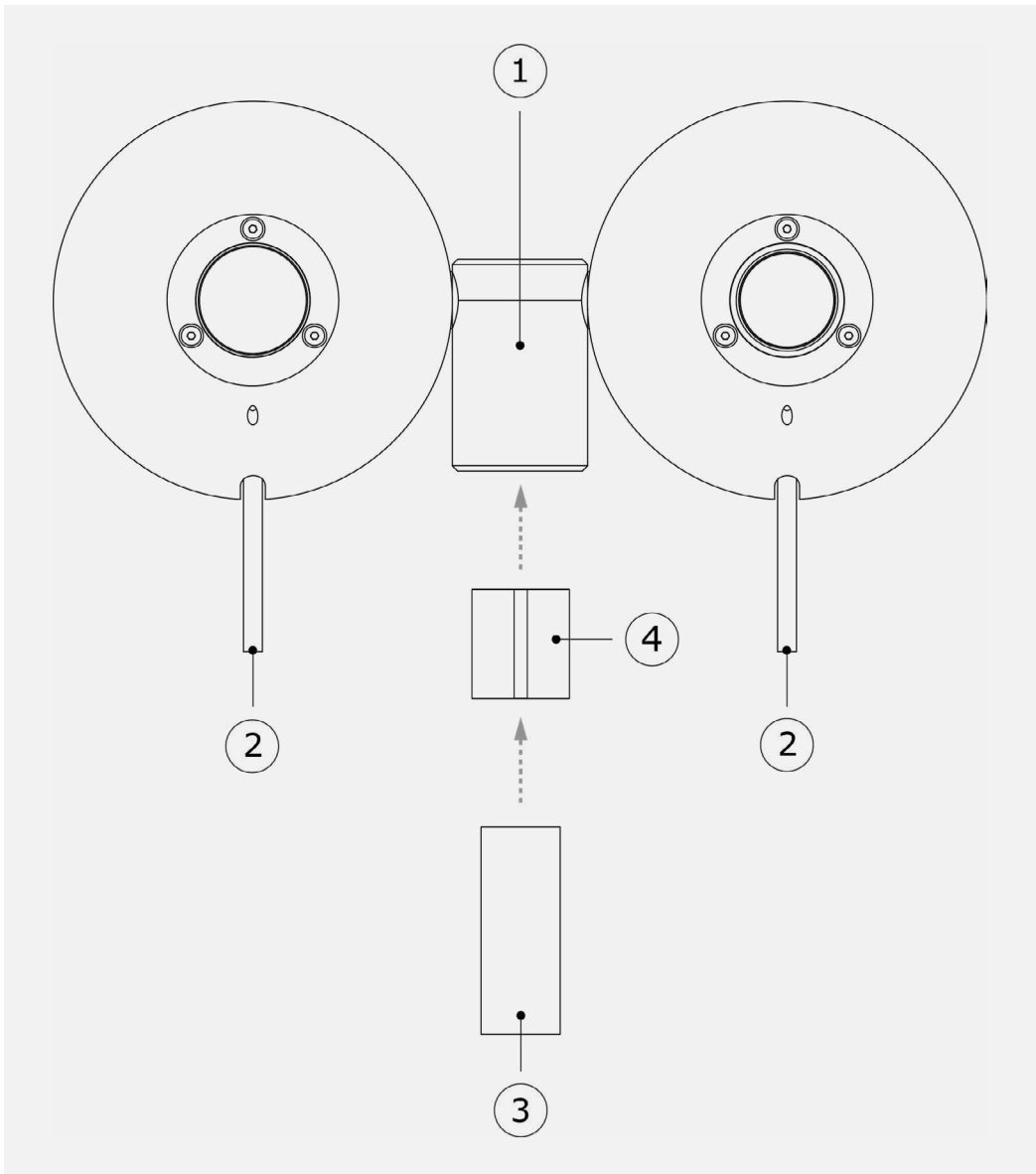

**Figure 2.1.3** Top view of NR01 fitting a 3/4 inch NPS tube (alternative mounting method):

1. leveling assembly for x- and y-axis
2. cable (cable 1 at the left, at pyranometer side, cable 2 at the right, at pyrgeometer side)
3. 3/4 inch NPS mounting tube (not included)
4. shim, included with NR01 delivery

## 2.2 Pyranometers model SR01

SR01's scientific name is pyranometer. A pyranometer measures the solar radiation received by a plane surface from a 180 ° field of view angle. This quantity, expressed in  $W/m^2$ , is called "hemispherical" solar radiation. NR01 typically is mounted horizontally. Measuring in the horizontal plane, downward solar radiation is called global solar radiation, upward solar radiation is called reflected solar radiation. The solar radiation spectrum extends roughly from 285 to  $3000 \times 10^{-9}$  m. By definition a pyranometer should cover that spectral range with a spectral selectivity that is as "flat" as possible.

In an irradiance measurement by definition the response to "beam" radiation varies with the cosine of the angle of incidence; i.e. it should have full response when the solar radiation hits the sensor perpendicularly (normal to the surface, sun at zenith, 0 ° angle of incidence), zero response when the sun is at the horizon (90 ° angle of incidence, 90 ° zenith angle), and 50 % of full response at 60 ° angle of incidence. A pyranometer should have a so-called "directional response" (older documents mention "cosine response") that is as close as possible to the ideal cosine characteristic.

In order to attain the proper directional and spectral characteristics, a pyranometer's main components are:

- A thermal sensor with black coating. It has a flat spectrum covering the 200 to  $50000 \times 10^{-9}$  m range, and has a near-perfect directional response. The coating absorbs all solar radiation and, at the moment of absorption, converts it to heat. The heat flows through the sensor to the sensor body. The thermopile sensor generates a voltage output signal that is proportional to the solar irradiance.
- A glass dome. This dome limits the spectral range from 285 to  $3000 \times 10^{-9}$  m (cutting off the part above  $3000 \times 10^{-9}$  m), while preserving the 180 ° field of view angle. Another function of the dome is that it shields the thermopile sensor from the environment (convection, rain).

Pyranometers can be manufactured to different specifications and with different levels of verification and characterization during production. The ISO 9060:1990 standard, "*Solar energy—specification and classification of instruments for measuring hemispherical solar and direct solar radiation*", distinguishes between 3 classes; secondary standard (highest accuracy), first class (second highest accuracy) and second class (third highest accuracy). SR01 is a second-class pyranometer.

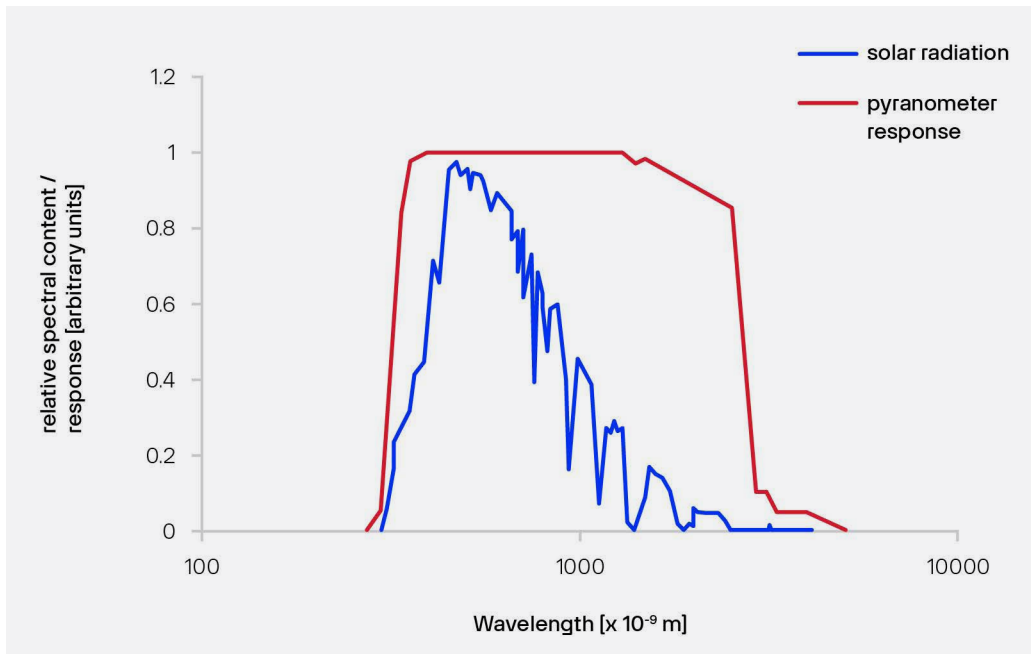

Figure 2.2.1 Spectral response of the pyranometer compared to the solar spectrum. The pyranometer only cuts off a negligible part of the total solar spectrum.

### 2.3 Pyrgeometers model IR01

IR01's scientific name is pyrgeometer. IR01 measures the longwave or far infrared (FIR) radiation received by a plane surface, in  $W/m^2$ , ideally from a  $180^\circ$  field of view angle. In meteorological terms pyrgeometers are used to measure "downward and upward longwave irradiance" (WMO definition). In case of IR01 the ideal  $180^\circ$  field of view angle has been reduced to  $150^\circ$ . This makes it possible to offer an instrument at an attractive price level, while the loss of accuracy is relatively small.

As secondary measurands, the sky temperature  $T_{sky}$  and the equivalent surface (ground) temperature  $T_{surface}$  can be measured. Both are so-called equivalent blackbody radiative temperatures, i.e. temperatures calculated from the pyrgeometer measurement assuming these are uniform-temperature blackbodies with an emission coefficient of 1.

Longwave radiation is the part of the radiation budget that is not emitted by the sun. The spectral range of the longwave radiation is not standardized. A practical cut-on is in the range of  $4$  to  $5 \times 10^{-6}$  m (see Figure 2.3.1).

In the longwave spectrum, the sky can be seen as a temperature source; colder than ground level ambient air temperature, with its lowest temperatures at zenith, getting warmer (closer to ambient air temperature) at the horizon. The uniformity of this longwave source is much better than that in the range of the solar spectrum, where the sun is a dominant contributor. The "equivalent blackbody" temperature, as a function of zenith angle, roughly follows the same pattern independent of the exact sky condition (cloudy or clear). This explains why for pyrgeometers the directional response is not very critical.

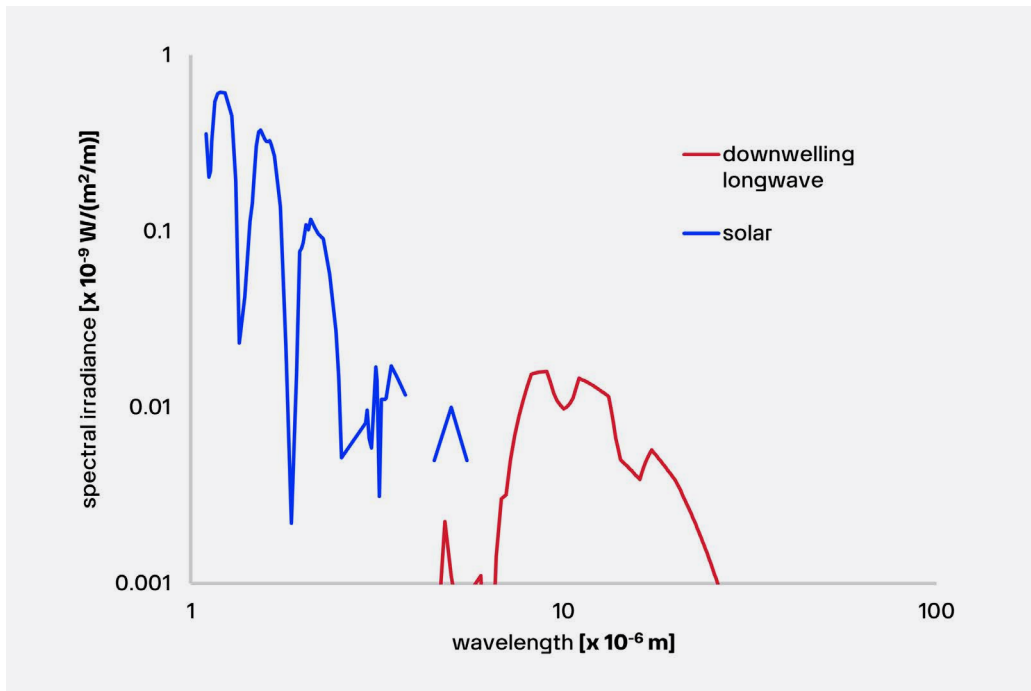

Figure 2.31 Atmospheric radiation as a function of wavelength plotted along two logarithmic axes to highlight the longwave radiation. Longwave radiation is mainly present in the  $4$  to  $50 \times 10^{-6}$  m range, whereas solar radiation is mainly present in the  $0.3$  to  $3 \times 10^{-6}$  m range. In practice, the two are measured separately using pyrgeometers and pyranometers.

The downwelling longwave radiation essentially consists of several components:

1. Low-temperature radiation from the universe, filtered by the atmosphere.  
The atmosphere is transparent for this radiation in the so-called atmospheric window (roughly the  $10$  to  $15 \times 10^{-6}$  m wavelength range).
2. Higher temperature radiation emitted by atmospheric gases and aerosols.
3. In presence of clouds or mist, the low-temperature radiation from the universe is almost completely blocked by the water droplets. The pyrgeometer then receives the radiation emitted by the water droplets.

Upwelling longwave irradiance is measured with downfacing instruments. These are presumably looking directly at the surface (absorption and emission of the atmosphere is low over a short distance of around  $2$  m), which behaves like a normal blackbody.

## 2.4 Typical measurement results

### 2.4.1 Pyranometer measurement results

Pyranometers theoretically only generate an output when the sun is in their field of view; i.e., when the sun is above the horizon.

The extraterrestrial global solar irradiance (GHI) can serve as the expected range limit to the local global solar irradiance. This range limit depends on time of day, coordinates and the day of the year. Lower values than the range limit will be measured depending on the local weather. Under some circumstances values may exceed the range limit, for instance when there is reflection against large cumulus clouds or snow-covered mountain slopes. Under these circumstances even the extraterrestrial solar direct normal irradiance or solar constant  $E_0$  of around  $1350 \text{ W/m}^2$  may be exceeded.

Reflected solar irradiance depends largely on the incoming GHI and surface properties. The study of albedo versus time offers a good method of quality assurance. In case of constant surface properties, the albedo over the day should not vary very much below solar zenith angles of  $60^\circ$ . Also in case of constant surface properties the albedo should show consistent patterns over the day from one day to the next.

The upfacing pyranometer may generate a negative signal at night, as specified by "zero offset a". For SR01 the specification is < 15 W/m<sup>2</sup> (unventilated).

## 2.4.2 Pyrgeometer measurement results

Pyrgeometers generate an output both during daytime and during nighttime. Please note that the output generated by an upfacing pyrgeometer usually has a negative sign.

The most important factors determining downward longwave irradiance are:

- ambient air temperature
- sky condition/cloud cover
- atmospheric moisture content

The largest errors in measurement of downward longwave irradiance are made during clear nights when dew is deposited on the instrument. In that case the output rises from a large negative value, in the order of – 100 W/m<sup>2</sup> (the correct value) to 0 W/m<sup>2</sup> (an incorrect value and a large error). The daytime measurement of downward longwave may contain a solar offset as specified under "solar offset" as < 15 W/m<sup>2</sup> at 1000 W/m<sup>2</sup> solar irradiance.

**Table 2.4.2.1** Expected pyrgeometer output U/S for an upfacing pyrgeometer at different ambient air temperatures,  $T_{\text{ambient}}$  and at different cloud conditions. Under clear sky conditions the U/S is around -100 W/m<sup>2</sup> while under cloudy conditions it will be close to 0 W/m<sup>2</sup>. Also calculated: the sky temperature,  $T_{\text{sky}}$  and the downward longwave irradiance  $E_{\downarrow}$ .

Expected pyrgeometer output downward longwave irradiance				
$T_{\text{ambient}}$	sky condition	U/S	$T_{\text{sky}}$	$E_{\downarrow}$
[°C]	[cloudy], [clear]	[W/m <sup>2</sup> ]	[°C]	[W/m <sup>2</sup> ]
-20	cloudy	0	-20	232
-20	clear sky	-100	-53	132
0	cloudy	0	0	314
0	clear sky	-100	-24	214
+30	cloudy	0	+30	477
+30	clear sky	-100	+12	377

A downfacing pyrgeometer will typically generate a voltage output signal very close to zero. The ground surface temperature usually is very close to the instrument temperature, so that the radiative exchange between instrument and surface is low.

**Table 2.4.2.2** Expected pyrgeometer output U/S for a downfacing pyrgeometer at different ambient air temperatures,  $T_{\text{ambient}}$  and at different cloud conditions. Under clear sky conditions as well as under cloudy conditions it will be close to 0 W/m<sup>2</sup>. Also calculated: the sky temperature,  $T_{\text{sky}}$  and the downward longwave irradiance  $E_{\downarrow}$ .

Expected pyrgeometer output upward longwave irradiance				
$T_{\text{ambient}}$	sky condition	U/S	$T_{\text{surface}}$	$E_{\uparrow}$
[°C]	[cloudy], [clear]	[W/m <sup>2</sup> ]	[°C]	[W/m <sup>2</sup> ]
-20	cloudy	0	-20	232
-20	clear sky	0	-20	232
0	cloudy	0	0	314
0	clear sky	0	0	314
+30	cloudy	0	+30	477
+30	clear sky	0	+30	477

## 2.5 Optional heating

A low-power heater is located in the body of the net radiometer at the pyrgeometer side. The heater is not necessarily switched on; recommended operation is to activate the heater when there is a risk of dew deposition. In case power is available, many users choose to keep the heater continuously on.

# 3 Specifications of NR01

## 3.1 Specifications of sensors of the NR01

NR01 is a 4-component net radiometer, consisting of 2 pyranometers type SR01, 2 pyrgeometers type IR01, a heater, leveling assembly for x- and y-axis and a Pt100 instrument body temperature sensor.

Pyranometers and pyrgeometers (the latter with additional input of the body temperature measurement) measure the solar and longwave radiation received by a plane surface, in  $W/m^2$ . For compensation of pyrgeometer emission in the longwave calculation and for calculation of sky- and surface temperature, a Pt100 temperature sensor is included in the instrument body. Working completely passive, using a thermopile sensor, the sensors generate a small output voltage proportional to these fluxes. Optional measurands include solar albedo and sunshine duration. NR01 can only be used in combination with a suitable measuring system. The instrument should be used in accordance with the recommended practices of ISO, IEC, WMO and ASTM.

Table 3.1.1 Specifications of NR01 (continued on next pages).

NR01 general specifications	
product type	4-component net radiometer
included sensors	2 x identical ISO 9060 second class pyranometer (see separate specification table for model SR01) 2 x identical pyrgeometer with 150 ° field of view angle (see separate specification table for model IR01)
spectral range solar	285 to 3000 x 10 <sup>-9</sup> m
spectral range longwave	4.5 to 42 x 10 <sup>-6</sup> m
leveling	Bubble level and a leveling assembly for x- and y-axis are included.
required sensor power	zero (passive sensor)
temperature sensor	Pt100
heater on pyrgeometer	12 VDC, 1.5 W (see below for details)
rated operating temperature range	-40 to +80 °C
rated operating relative humidity range	0 to 100 %

required readout	4 x differential voltage channel or 4 x single ended voltage channel, input resistance > 10 <sup>6</sup> Ω 1 x temperature channel for Pt100
------------------	---

standards governing use of the instrument	ISO/TR 9901:1990 Solar energy -- Field pyranometers -- Recommended practice for use  ASTM G183 - 05 Standard Practice for Field Use of Pyranometers, Pyrheliometers and UV Radiometers  WMO-No. 8, Guide to Meteorological Instruments and Methods of Observation, seventh edition 2008, paragraph 7.4 "measurement of total and long-wave radiation"
---	---

### NR01 measurands

measurand all 4 radiometers	net radiation
-----------------------------	---------------

measurand in SI units	irradiance in W/m <sup>2</sup>
-----------------------	--------------------------------

measurement function/required programming net radiation	$E^* = E_{\downarrow} - E_{\uparrow} = E_{g\downarrow h} - E_r\uparrow + E_l\downarrow - E_l\uparrow$
---	---

measurand upfacing pyranometer	global solar radiation
--------------------------------	------------------------

measurand in SI units	irradiance in W/m <sup>2</sup>
-----------------------	--------------------------------

measurement function/required programming global solar irradiance	$E_{g\downarrow h} = U/S$
---	---------------------------

measurand downfacing pyranometer	reflected solar radiation
----------------------------------	---------------------------

measurand in SI units	irradiance in W/m <sup>2</sup>
-----------------------	--------------------------------

measurement function/required programming reflected solar irradiance	$E_r\uparrow = U/S$
--	---------------------

measurand upfacing pyrgeometer	downward longwave radiation*
--------------------------------	------------------------------

measurand in SI units	irradiance in W/m <sup>2</sup>
-----------------------	--------------------------------

measurement function/required programming downward longwave radiation	$E_l\downarrow = U/S + \sigma \cdot (T + 273.15)^4$
---	---

measurand downfacing pyrgeometer	upward longwave radiation*
----------------------------------	----------------------------

measurands in SI units	irradiance in W/m <sup>2</sup>
------------------------	--------------------------------

measurement function/required programming upward longwave irradiance	$E_l \uparrow = U/S + \sigma \cdot (T + 273.15)^4$
optional measurand downfacing pyrgeometer	surface temperature*
optional measurand in SI units	equivalent blackbody radiative temperature in °C
measurement function/required programming surface temperature	$T_{\text{surface}} = (E_l \uparrow / \sigma)^{1/4} - 273.15$
optional measurand upfacing pyrgeometer	sky temperature*
optional measurand in SI units	equivalent blackbody radiative temperature in °C
measurement function/required programming sky temperature	$T_{\text{sky}} = (E_l \downarrow / \sigma)^{1/4} - 273.15$
optional measurand pyranometers	albedo or solar reflectance
optional measurand in SI units	albedo or solar reflectance in (W/m <sup>2</sup> )/(W/m <sup>2</sup> )
measurement function/required programming albedo	albedo = solar reflectance = $E_r \uparrow / E_g \downarrow_h$
optional measurand upfacing pyranometer	sunshine duration
optional measurand in SI units	sunshine duration in h
measurement function/optional programming sunshine duration	according to WMO guide paragraph 8.2.2
measurand Pt100	instrument body temperature $T_{\text{body}}$
measurand in SI units	temperature in °C
*required measurand: instrument body temperature.	
<b>NR01 mounting, cabling, transport</b>	
standard cable length (see options)	2 x 5 m
cable diameter	$5.3 \times 10^{-3}$ m
cable replacement	Cable can be removed and installed by the user provided that the cable is sealed at the instrument side against humidity ingress. Consult Hukx for instructions or use Hukx-supplied parts.

instrument mounting	A leveling assembly for x- and y-axis is included. It fits a 1 inch NPS tube (the tube's recommended outer diameter equals $33.4 \times 10^{-3}$ m). Attach mounting tube to leveling assembly using a hex key size 4.0 mm (not included) for bolt size M5. With the NR01 shim, included in NR01's delivery, a $\frac{3}{4}$ inch NPS tube may also be used. This tube's recommended outer diameter equals $26.8 \times 10^{-3}$ m. Tubes are not included.
leveling accuracy	< 0.6 ° bubble entirely in ring
IP protection class	IP67
gross weight including 2 x 5 m cable	approx. 2 kg
net weight including 2 x 5 m cable	approx. 1.5 kg
<b>Heating</b>	
heater operation	The heater is not necessarily switched on. The recommended operation is to activate the heater when there is a risk of dew deposition.
required heater power	1.5 W at 12 VDC (The heater is not necessarily active)
heater resistance	95 Ω
<b>Calibration</b>	
calibration traceability solar	to WRR (see SR01 for details)
calibration traceability longwave	to WISG (see IR01 for details)
calibration traceability Pt100	to ITS-90
validity of calibration	Based on experience the instrument sensitivity will not change during storage. During use under exposure to solar radiation the instrument "non-stability" specification is applicable.
recommended recalibration interval	2 years

## Measurement accuracy

uncertainty of the measurement

Statements about the overall measurement uncertainty can only be made on an individual basis. See the chapter on uncertainty evaluation.

temperature sensor accuracy class

Pt100 DIN EN 60751 class A

uncertainty Pt100

$\pm (0.15 \text{ °C} + 0.002 \cdot |T|)$

## WMO estimate of achievable measurement uncertainty

achievable measurement accuracy for daily sums of net radiation,  $E^*$ , according to WMO under nominal and recommended exposure (WMO guide annex 1.B)

$\pm 0.4 \times 10^6 \text{ J/m}^2$  for  $< 8 \times 10^6 \text{ J/m}^2$   
 $\pm 5 \%$  for  $> 8 \times 10^6 \text{ J/m}^2$   
see also SR01 and IR01 specifications

## Versions/options

longer cable, in multiples of 5 m,  
cable lengths above 20 m in multiples of 10 m

option code = total cable length

internal temperature sensor

measuring the instrument body temperature:  
version code = T1 for Pt100 DIN class A,  
version code = T2 for thermistor 10 k $\Omega$  at 25 °C

## 3.2 Specifications of pyranometer SR01

SR01 pyranometer measures the solar radiation received by a plane surface from a from a 180 ° field of view angle. This quantity, expressed in  $W/m^2$ , is called “hemispherical” solar radiation. NR01, in which 2 x SR01 are incorporated, is typically mounted horizontally. Measuring in the horizontal plane, downward solar radiation is called global solar radiation, upward solar radiation is called reflected solar radiation. Working completely passive, using a thermopile sensor, SR01 generates a small output voltage proportional to this flux. It can only be used in combination with a suitable measurement system. The instrument is classified according to ISO 9060 and should be used in accordance with the recommended practices of ISO, IEC, WMO and ASTM.

Table 3.2.1 Specifications of SR01 (continued on next page).

### SR01 pyranometer measurement specifications: list of classification criteria of ISO 9060\*

ISO classification (ISO 9060: 1990)	second class pyranometer
WMO performance level (WMO-No-8, seventh edition 2008)	moderate quality pyranometer
response time (95 %)	18 s
zero offset a (response to 200 $W/m^2$ net thermal radiation)	$< \pm 15 W/m^2$ unventilated
zero offset b (response to 5 K/h change in ambient temperature)	$< \pm 4 W/m^2$
non-stability	$< \pm 1\%$ change per year
non-linearity	$< \pm 1\%$ (100 to 1000 $W/m^2$ )
directional response	$< \pm 25 W/m^2$
spectral selectivity	$< \pm 5\%$ (0.35 to $1.5 \times 10^{-6} m$ )
temperature response	$< \pm 3\%$ (-10 to +40 °C)
tilt response	$< \pm 2\%$ (0 to 90° at 1000 $W/m^2$ )

\*For the exact definition of pyranometer ISO 9060 specifications see the appendix.

## SR01 pyranometer additional specifications

measurand	global and reflected solar radiation
measurand in SI radiometry units	irradiance in $W/m^2$
field of view angle	$180^\circ$
measurement range	0 to $2000 W/m^2$
sensitivity range	7 to $30 \times 10^{-6} V/(W/m^2)$
sensitivity (nominal)	$15 \times 10^{-6} V/(W/m^2)$
expected voltage output	application under natural solar radiation: $-0.1$ to $+50 \times 10^{-3} V$
measurement function/required programming	$E = U/S$
sensor resistance range	40 to $60 \Omega$
required sensor power	zero (passive sensor)
spectral range (20 % transmission points)	285 to $3000 \times 10^{-9} m$

### Calibration

calibration traceability	to WRR
calibration hierarchy	from WRR through ISO 9846 and ISO 9847, applying a correction to reference conditions
calibration method	indoor calibration according to ISO 9847, Type IIc
calibration uncertainty	$< 2.4 \% (k = 2)$
reference conditions	$20^\circ C$ , normal incidence solar radiation, horizontal mounting, irradiance level $1000 W/m^2$

## Measurement accuracy

uncertainty of the measurement

Statements about the overall measurement uncertainty can only be made on an individual basis. See the chapter on uncertainty evaluation.

global horizontal irradiance:  
WMO estimate on achievable accuracy  
for daily sums (see appendix for a definition  
of the measurement conditions)

± 10 %

global horizontal irradiance:  
WMO estimate on achievable accuracy  
for hourly sums (see appendix for a definition  
of the measurement conditions)

± 20 %

### 3.3 Specifications of pyrgeometer IR01

IR01 pyrgeometer measures the longwave irradiance received by a plane surface, in  $W/m^2$ , from a  $150^\circ$  field of view angle, which approximates the ideal  $180^\circ$  field of view angle. NR01 contains two IR01s; one facing up, the other facing down.

In meteorological terms these IR01s measure downward and upward longwave irradiance. Working completely passive, using a thermopile sensor, IR01 generates a small output voltage proportional to the radiation balance between the instrument and the source it faces. The instrument is not subject to classification. IR01 measures during both day and night. It should be used in accordance with the recommended practices of WMO. For high accuracy measurements the user should consider using NR01's incorporated heater.

Table 3.3.1 Specifications of IR01 (continued on next page).

#### IR01 pyrgeometer specifications

##### Measurands

measurand	longwave radiation
measurand in SI radiometry units	longwave irradiance in $W/m^2$
optional measurand	equivalent blackbody radiative temperature in $^\circ C$
spectral range	$4.5$ to $42 \times 10^{-6}$ m
solar offset	$< 15 W/m^2$ (at $1000 W/m^2$ global horizontal irradiance on the window)

## Main specifications

ISO and WMO classification	not applicable
field of view angle	150 °
response time (95 %)	18 s
sensitivity (nominal)	$15 \times 10^{-6} \text{ V}/(\text{W}/\text{m}^2)$
sensitivity range	5 to $25 \times 10^{-6} \text{ V}/(\text{W}/\text{m}^2)$
temperature dependence	$< \pm 3 \%$ (-10 to +40 °C)
required sensor power	zero (passive sensor)

## Additional specifications

zero offset b (response to 5 K/h change in ambient temperature)	$< \pm 4 \text{ W}/\text{m}^2$
non-stability	$< \pm 1 \%$ change per year
non-linearity	$< \pm 2.5 \%$ (100 to 300 $\text{W}/\text{m}^2$ , relative to 200 $\text{W}/\text{m}^2$ sensor to source exchange)
measurement range	-300 to + 300 $\text{W}/\text{m}^2$ (sensor to source exchange: U/S)
tilt dependence	$< \pm 2 \%$ (0 to 90 ° at 300 $\text{W}/\text{m}^2$ )
sensor resistance range	25 to 400 $\Omega$
expected voltage output	application for outdoor measurement of downward longwave irradiance: $-7.5$ to $+7.5 \times 10^{-3} \text{ V}$
measurement function/required programming for irradiance in $\text{W}/\text{m}^2$	$E = U/S + \sigma \cdot (T + 273.15)^4$
measurement function/optional programming for equivalent blackbody radiative temperature in °C	$T = (E/\sigma)^{1/4} - 273.15$

## Calibration

calibration traceability	to WISG
calibration hierarchy	from WISG through Hukx internal IRC calibration procedure employing a blackbody
calibration method	indoor calibration under a blackbody, by comparison reference pyrgometer traceable to WISG
calibration uncertainty	< 7 % (k = 2)
reference conditions	horizontal mounting, atmospheric longwave irradiance, clear sky nights, 20 °C

## Measurement accuracy

uncertainty of the measurement	Statements about the overall measurement uncertainty can only be made on an individual basis. See the chapter on uncertainty evaluation.
--------------------------------	--

### 3.4 Dimensions of NR01

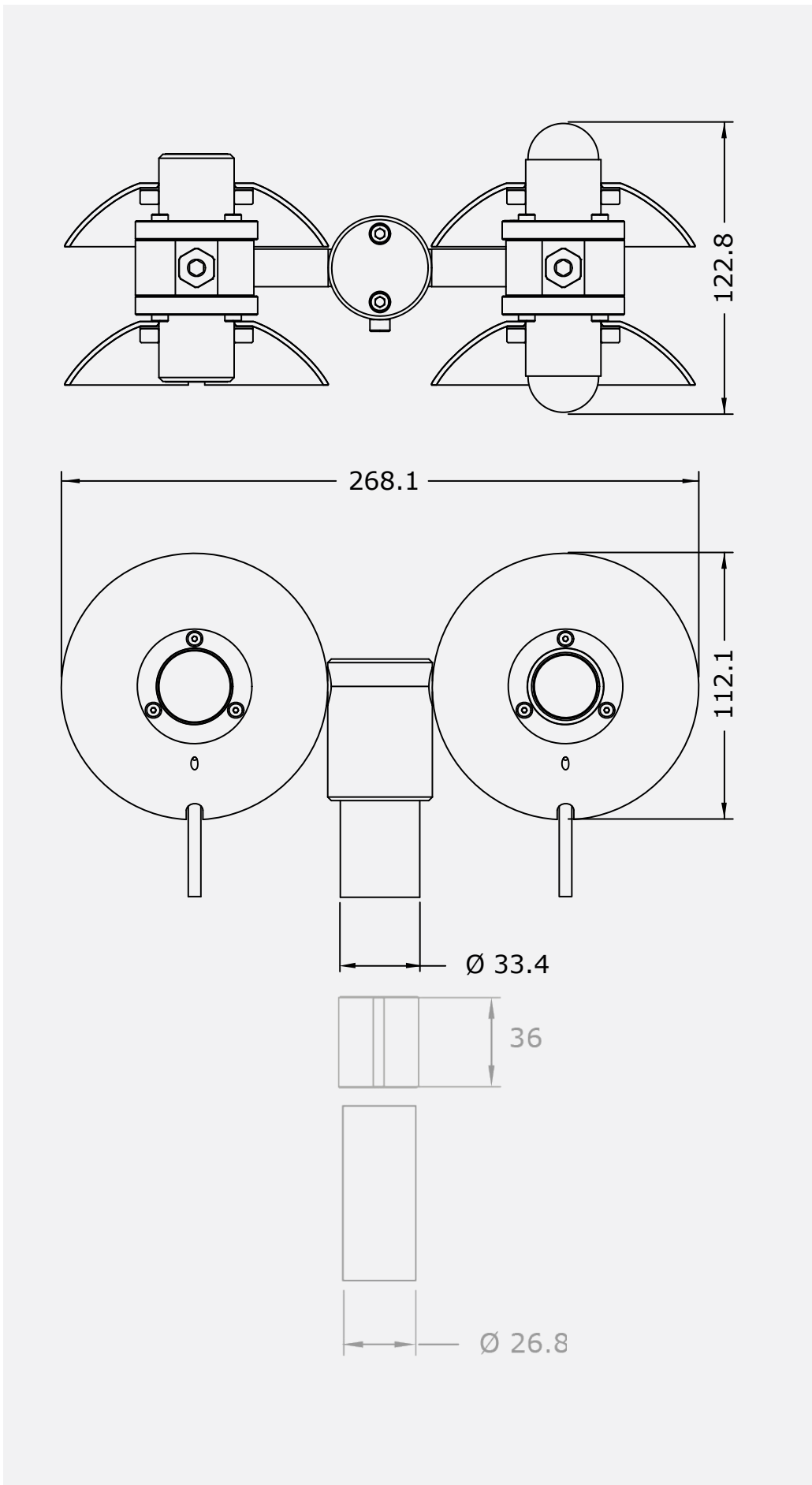

**Figure 3.4.1** Dimensions of NR01 in  $\times 10^{-3}$  m. NR01 fits a 1 inch NPS tube (recommended outer tube diameter is  $33.4 \times 10^{-3}$  m). Alternatively (displayed in gray), NR01 may be mounted on a  $\frac{3}{4}$  inch NPS tube using NR01's shim.

# 4 Standards and recommended practices for use

Pyranometers are classified according to the ISO 9060 standard and the WMO-No. 8 Guide. The combination of a pyranometer and pyrgeometer can be considered a pyrradiometer (covering the full spectrum together). These are standardized by WMO. Pyrgeometers are not subject to standardization. In any application the instrument should be used in accordance with the recommended practices of ISO, IEC, WMO and/or ASTM.

## 4.1 Classification standards for pyranometers and pyrradiometers

**Table 4.1.1** Standards for pyranometer classification. See the appendix for definitions of pyranometer specifications, and a table listing the specification limits.

Standards for pyranometer classification		
ISO standard	equivalent ASTM standard	WMO
ISO 9060:1990 Solar energy -- specification and classification of instruments for measuring hemispherical solar and direct solar radiation	not available	WMO-No. 8; Guide to Meteorological Instruments and Methods of Observation, chapter 7, measurement of radiation, 7.3 "measurement of global and diffuse solar radiation"

**Table 4.1.2** Standards for pyrradiometer classification.

NOTE: Hukx does not use the WMO classification because its specifications are not sufficiently clear.

Standards for pyrradiometer classification		
ISO standard	equivalent ASTM standard	WMO
not available	not available	WMO-No. 8; Guide to Meteorological Instruments and Methods of Observation, chapter 7, measurement of radiation, 7.4 "measurement of total and long-wave radiation"

## 4.2 General use for net radiation measurement

Table 4.2.1 Standards with recommendations for instrument use in net radiation measurement.

Standards for instrument use for net radiation		
ISO standard	equivalent ASTM standard	WMO
ISO/TR 9901:1990 Solar energy -- Field pyranometers -- Recommended practice for use	ASTM G183 - 05 Standard Practice for Field Use of Pyranometers, Pyrheliometers and UV Radiometers	WMO-No. 8; Guide to Meteorological Instruments and Methods of Observation, chapter 7, measurement of radiation, 7.3 "measurement of global and diffuse solar radiation", 7.4 "measurement of total and long-wave radiation"

## 4.3 General use for sunshine duration measurement

According to the World Meteorological Organization (WMO, 2003), sunshine duration during a given period is defined as the sum of that sub-period for which the direct solar irradiance exceeds 120 W/m<sup>2</sup>.

WMO has approved the "pyranometric method" to estimate sunshine duration from pyranometer measurements (Chapter 8 of the WMO Guide to Instruments and Observation, 2008). This implies that a pyranometer may be used, in combination with appropriate software, to estimate sunshine duration.

Ask for our application note.

Table 4.3.1 Standards with recommendations for instrument use in sunshine duration measurement.

Standards for instrument use for sunshine duration	
WMO	
WMO-No. 8; Guide to Meteorological Instruments and Methods of Observation, chapter 8, measurement of sunshine duration, 8.2.2 Pyranometric Method	

## 4.4 Specific use in meteorology and climatology

The World Meteorological Organization (WMO) is a specialized agency of the United Nations. It is the UN system's authoritative voice on the state and behavior of the earth's atmosphere and climate. WMO publishes WMO-No. 8; Guide to Meteorological Instruments and Methods of Observation, in which a table is included on "level of performance" of pyranometers and a table with "characteristics of operational pyrradiometers" (table 7.7). For pyranometers, nowadays WMO conforms to the ISO classification system.

Hukx does not use the WMO characteristics of pyrradiometers because its specification is not sufficiently clear.

For high accuracy measurements, the following manual may serve as a reference: Baseline Surface Radiation Network (BSRN) Operations Manual, Version 2.1, L. J. B. McArthur, April 2005, WCRP-121, WMO/TD-No. 1274.

This manual also includes chapters on installation (paragraph 4.1) and calibration (paragraph 8.4).

# 5 Installation of NR01

## 5.1 Site selection and installation

Table 5.1.1 Recommendations for installation of NR01 and RA01.

location	<p>The horizon should be as free from obstacles as possible. Ideally there should be no objects between the course of the sun and the instrument.</p> <p>The soil surface should be representative of the area under observation. If this is not the case, consider using RA01.</p>
mechanical mounting/thermal insulation	<p>A leveling assembly for x- and y axis is included with NR01. NR01 is suitable for mounting on a 1 inch NPS tube and, alternatively, on a ¾ inch NPS tube using the shim included with NR01's delivery. Recommended outer tube diameters are <math>33.4 \times 10^{-3}</math> m (1 inch tube) and <math>26.8 \times 10^{-3}</math> m (¾ inch tube). Fixation is done using a 4 mm hex key. Do not mount the instrument on objects that become very hot (black coated metal plates).</p>
leveling	<p>Use the bubble level and leveling assembly for x- and y axis. Remove a sun screen for inspection of the bubble level. Alternatively put an external level on the pyrgeometer window.</p>
instrument orientation	<p>By convention with the cable exit pointing to the nearest pole (so the cable exit should point north in the northern hemisphere, south in the southern hemisphere).</p>
installation height	<p>WMO recommends a distance of 1.5 to 2 m between soil surface and downfacing sensors (reducing the effect of shadows and in order to obtain good spatial averaging).</p>

## 5.2 Installation of the sun screens

NR01 includes 4 sun screens. For the downfacing sensors these are actually employed as “glare screens”, to prevent that solar radiation falls onto the downfacing sensors when the sun is at a high zenith angle. The SCR01 sun screen can be installed and removed using a hex key (size 2 mm). See the drawing below.

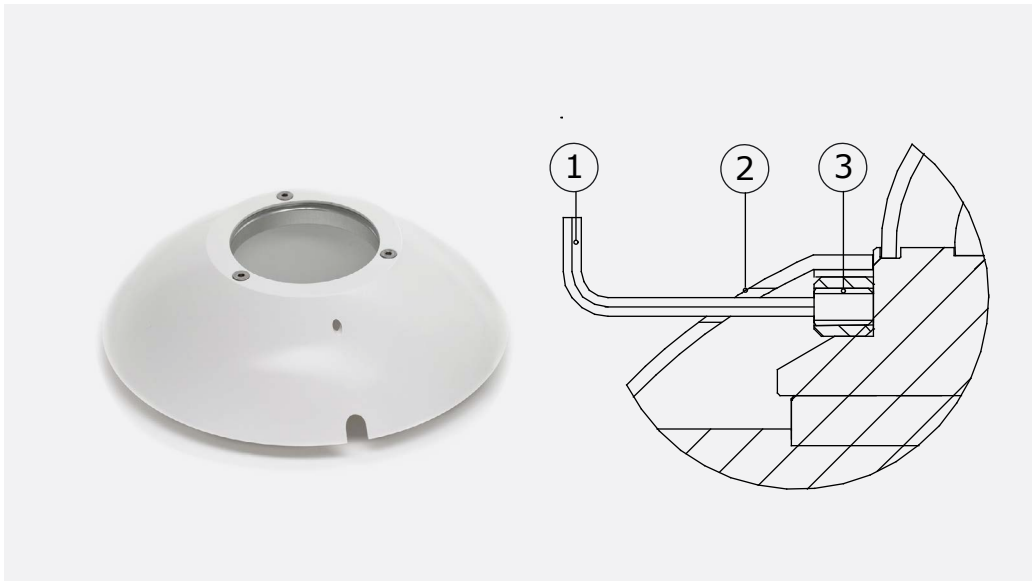

Figure 5.21 SCR01 sun screen and its installation and removal: turn the set screw using the hex key and lift off the sun screen to remove.  
1. hex key  
2. sun screen  
3. set screw

## 5.3 Mounting NR01 on a tube

A leveling assembly for x- and y axis is included with NR01. NR01 is suitable for mounting on a 1 inch NPS tube. The recommended outer diameter of such a tube is  $33.4 \times 10^{-3}$  m. This tube is not included with NR01 deliveries. Use a 4 mm hex key for fixation.

Optionally, NR01 may be mounted on a  $\frac{3}{4}$  inch NPS tube. Such a tube is not included with NR01 deliveries. Included with NR01 is a metal shim. The shim allows mounting NR01 on a  $\frac{3}{4}$  inch tube (with a recommended outer diameter of  $26.8 \times 10^{-3}$  m). Otherwise the shim is not needed for installing NR01. Fixation is done using a 4 mm hex key.

Figure 2.1.3 shows an ‘exploded view’ of mounting NR01 on a  $\frac{3}{4}$  inch NPS tube.



Figure 5.31 Shim, included with NR01 delivery, for optional mounting on a  $\frac{3}{4}$  inch tube.

## 5.4 Electrical connection of NR01

In order to operate, NR01 should be connected to a measurement system, typically a so-called data logger. NR01 contains passive sensors that do not need any power, however there is an on-board heating resistor in the instrument body, that may be switched on to prevent dew deposition. Cables generally act as a source of distortion, by picking up capacitive noise. We recommend keeping the distance between a data logger or amplifier and the sensor as short as possible. For cable extension, see the appendix on this subject.

NOTE: upfacing sensors measuring downward radiation are indicated by SR01 ↓ and IR01 ↓.

downfacing sensors measuring upward radiation are indicated by SR01 ↑ and IR01 ↑.

**Table 5.4.1** The electrical connection of the standard NR01 with Pt100. PCB04 and PCB05 are internal printed circuit boards. There are two cables, marked cable 1 and cable 2, cable 1 at the pyranometer side, cable 2 at the pyrgeometer side.

connection cable 1			connection cable 2		
PCB04	wire		PCB05	wire	
1	blue	SR01 ↓ [-]	1	brown	heater
2	red	SR01 ↓ [+]	2	red	Pt100 [+]
3	yellow	IR01 ↓ [-]	3	white	Pt100 [+]
4	brown	IR01 ↓ [+]	4	blue	Pt100 [-]
5	gray	IR01 ↑ [-]	5	green	Pt100 [-]
6	pink	IR01 ↑ [+]	6	yellow	heater
7	green	SR01 ↑ [-]		pink	not connected
8	white	SR01 ↑ [+]		gray	not connected
11	black	shield	10	black	shield

**Table 5.4.2** The electrical connection of the optional NR01-T2 with 10 kΩ thermistor. PCB04 and PCB05 are internal printed circuit boards. There are two cables, marked cable 1 and cable 2, cable 1 at the pyranometer side, cable 2 at the pyrgeometer side.

connection cable 1			connection cable 2		
PCB04	wire		PCB05	wire	
1	blue	SR01 ↓ [-]	1	brown	heater
2	red	SR01 ↓ [+]	2	red	10 kΩ thermistor [+]
3	yellow	IR01 ↓ [-]	3	white	10 kΩ thermistor [+]
4	brown	IR01 ↓ [+]	4	blue	10 kΩ thermistor [-]
5	gray	IR01 ↑ [-]	5	green	10 kΩ thermistor [-]
6	pink	IR01 ↑ [+]	6	yellow	heater
7	green	SR01 ↑ [-]		pink	not connected
8	white	SR01 ↑ [+]		gray	not connected
11	black	shield	10	black	shield

Note 1: optional 10 kΩ thermistors are internally connected in a 4-wire configuration like the Pt100 but usually connected to electronics used in 2-wire configuration.

Note 2: the heater is not necessarily connected. In case it is connected, the polarity of the connection is not important.

Note 3: signal wires are insulated from ground wires and from the sensor body. Insulation resistance is tested during production and is larger than  $1 \times 10^6 \Omega$ .

**Table 5.4.3** Internal connection diagram of NR01 for servicing purposes only.

NOTE: internal connections are replaced by non-serviceable flexfoil connectors in the latest models.

internal electrical connection for servicing (early NR01 models)				
PCB04 connection	PCB04 terminal	PCB05 connection	PCB05 terminal	polarity
3		8	IR01 ↓ [-]	-
4		7	IR01 ↓ [+]	+
5		12	IR01 ↑ [-]	-
6		11	IR01 ↑ [+]	+
13	SR01 ↓ [-]			+
14	SR01 ↓ [+]			-
9	SR01 ↑ [-]			+
3	SR01 ↑ [+]			-

## 5.5 Requirements for data acquisition/amplification

The selection and programming of data loggers is the responsibility of the user. Please contact the supplier of the data acquisition and amplification equipment to see if directions for use with the NR01 are available.

In case programming for similar instruments is available, this can typically also be used. NR01 can usually be treated in the same way as other 4-component net radiometers.

Table 5.5.1 Requirements for data acquisition and amplification equipment for NR01 in the standard configuration.

voltage measurement uncertainty requirements	<p>4 input channels  recommended: <math>&lt; \pm 5 \times 10^{-6} \text{ V}</math>  accepted: <math>&lt; \pm 20 \times 10^{-6} \text{ V}</math>  (valid for the entire expected temperature range of the acquisition/amplification equipment)  NOTE: a <math>15 \times 10^{-6} \text{ V}</math> uncertainty translates to <math>1 \text{ W/m}^2</math>  NOTE: some sources of uncertainty cancel when measuring the net-radiation</p>
data logger and software	<p>The data logger and its software should be able to store data, and to perform division by the sensitivity to calculate the solar and longwave irradiance and other optional measurands.</p>
voltage measurement input resistance	<p><math>&gt; 1 \times 10^6 \Omega</math></p>
open circuit detection (WARNING)	<p>Open-circuit detection should not be used, unless this is done separately from the normal measurement by more than 5 times the sensor response time and with a small current only. Thermopile sensors are sensitive to the current that is used during open circuit detection. The current will generate heat, which is measured and will appear as an offset.</p>
temperature measurement uncertainty requirements	<p><math>&lt; \pm 0.2 \text{ }^\circ\text{C}</math>  Pt100 or optional <math>10 \text{ k}\Omega</math> thermistor measurement  NOTE: a <math>0.2 \text{ }^\circ\text{C}</math> uncertainty translates to <math>1 \text{ W/m}^2</math>  NOTE: the uncertainty of the temperature measurement does not play a role when measuring the net-radiation</p>
optional heating on pyrgeometer	<p>NR01 has a 12 VDC, 1.5 W heater on board, which may optionally be activated to keep the pyrgeometers above dew point. Some users prefer to have the heater on full-time, others prefer to switch it on during nighttime only.</p>

# 6

## Making a dependable measurement

### 6.1 The concept of dependability

A measurement is called “dependable” if it is reliable, i.e. measuring within required uncertainty limits, for most of the time and if problems, once they occur, can be solved quickly.

The requirements for a measurement with a net radiometer may be expressed by the user as:

- required uncertainty of the measurement (see following paragraphs)
- requirements for maintenance and repairs (possibilities for maintenance and repair including effort to be made and processing time)
- a requirement to the expected instrument lifetime (until it is no longer feasible to repair)

It is important to realize that the uncertainty of the measurement is not only determined by the instrument but also by the way it is used.

See also ISO 9060 note 5. In case of pyranometers and pyrgeometers the measurement uncertainty as obtained during outdoor measurements is a function of:

- the instrument class (applicable to pyranometers)
- the calibration procedure/uncertainty
- the duration of instrument employment under natural sunlight (involving the instrument stability specification)
- the measurement conditions (such as tilting, ventilation, shading, instrument temperature)
- maintenance (mainly fouling)
- the environmental conditions\* (such as temperature, position of the sun, presence of clouds, horizon, representativeness of the location. For pyrgeometers, this also involves the presence of natural sunlight which produces a solar offset)

Therefore, statements about the overall measurement uncertainty under outdoor conditions can only be made on an individual basis, taking all these factors into account.

\* Defined at Hukx as all factors outside the instrument that are relevant to the measurement such as the cloud cover (presence or absence of direct radiation), sun position, the local horizon (which may be obstructed) or condition of the ground (when tilted). The environmental conditions also involve the question whether or not the measurement at the location of measurement is representative of the quantity that should be measured.

## 6.2 Reliability of the measurement

A measurement is reliable if it measures within required uncertainty limits for most of the time. We distinguish between two causes of unreliability of the measurement:

- related to the reliability of the net radiometer and its design, manufacturing, calibration (hardware reliability)
- related to the reliability of the measurement uncertainty (measurement reliability), which involves hardware reliability as well as conditions of use

Most of the hardware reliability is the responsibility of the instrument manufacturer. The reliability of the measurement however is a joint responsibility of instrument manufacturer and user. As a function of user requirements, taking into account measurement conditions and environmental conditions, the user will select an instrument of a certain class, and define maintenance support procedures.

In many situations there is a limit to a realistically attainable accuracy level. This is due to conditions that are beyond control once the measurement system is in place. Typical limiting conditions are:

- The measurement conditions, for instance when working at extreme temperatures when the instrument temperature is at the extreme limits of the rated temperature range.
- The environmental conditions, for instance when installed at a sub-optimal measurement location with obstacles in the path of the sun.
- The environmental conditions, for instance when assessing net radiation, the downfacing pyrgeometer measurement may not be representative of irradiance received in that particular area.

The measurement reliability can be improved by maintenance support. Important aspects are:

- Dome/window fouling by deposition of dust, dew, rain or snow. Fouling results in undefined measurement uncertainty (sensitivity and directional error are no longer defined). With pyrgeometers the most important source of unreliability is deposition of water on the window. Water completely blocks the longwave radiation flux between sensor and sky. In particular at clear nights this causes very large errors. Water deposition under clear-sky nighttime conditions can largely be prevented by using the instrument heater. This should be solved by regular inspection and cleaning.
- Sensor instability. Maximum expected sensor aging is specified per instrument as its non-stability in [% change / year]. In case the sensor is not recalibrated, the uncertainty of the sensitivity will gradually increase. This is solved by regular recalibration.
- Moisture condensing under pyranometer domes resulting in a slow change of sensitivity (within specifications). This is solved by regular replacement of desiccant or by maintenance (drying the entire sensor) in case the sensor allows this. For non-serviceable sensors like Hukx second class pyranometers (for example model SR01 in NR01), this may slowly develop into a defect. For first class and secondary standard models (for instance model SR11 first class pyranometer) extra desiccant (in a set of 5 bags in an air tight bag) is available.

- One of the larger errors in the daytime measurement of downwelling longwave irradiance is the offset caused by solar radiation; the “solar offset”. Errors due to solar offset, are of the order of  $+15 \text{ W/m}^2$  at  $1000 \text{ W/m}^2$  global horizontal irradiance. For ultra-high accuracy measurements this offset can be reduced by around 60% by “shading”, which means preventing the direct radiation to reach the instrument. Shading is typically done by using a shading disk on a solar tracker. Shading is often applied with research-grade pyrgeometers like Hukx model IR20. The overall accuracy of model IR01 does not justify the use of shading.

Another way to improve measurement reliability is to introduce redundant sensors.

- The use of redundant instruments allows remote checks of one instrument using the other as a reference, which leads to a higher measurement reliability.

### 6.3 Repair and maintenance

Dependability is not only a matter of reliability but also involves the reaction to problems; if the processing time of service and repairs is short, this contributes to the dependability.

Hukx net radiometers are designed to allow easy maintenance and repair.

The main maintenance actions are:

- replacement of desiccant (not applicable for NR01).
- replacement of cabling.

For optimization of dependability a user should:

- Design a schedule of regular maintenance.
- Design a schedule of repair or replacement in case of defects.

When operating multiple instruments in a network, Hukx recommends keeping procedures simple and having a few spare instruments to act as replacements during service, recalibrations and repair.

### 6.4 Uncertainty evaluation

The uncertainty of a measurement under outdoor or indoor conditions depends on many factors, see paragraph 1 of this chapter. It is not possible to give one figure for pyranometer, pyrgeometer or net radiometer measurement uncertainty. The work on uncertainty evaluation of measurements with pyranometer is “in progress”. There are several groups around the world participating in standardization of the method of calculation. The effort aims to work according to the guidelines for uncertainty evaluation (according to the “Guide to Expression of Uncertainty in Measurement” or GUM). Uncertainty evaluation of measurements with pyrgeometers and net-radiometers at present (2015) has not yet received attention from standardization organizations.

## 6.4.1 Evaluation of pyranometer measurement uncertainty

Hukx actively participates in the discussions about pyranometer measurement uncertainty; we also provide spreadsheets, reflecting the latest state of the art, to assist our users in making their own evaluation. The input to the assessment is summarized:

1. The formal evaluation of uncertainty should be performed in accordance with ISO 98-3 Guide to the Expression of Uncertainty in Measurement, GUM.
2. The specifications of the instrument according to the list of ISO 9060 classification of pyranometers and pyrhemometers are entered as limiting values of possible errors, to be analyzed as type B evaluation of standard uncertainty per paragraph 4.3.7. of GUM. A priori distributions are chosen as rectangular.
3. A separate estimate has to be entered to allow for estimated uncertainty due to the instrument maintenance level.
4. The calibration uncertainty has to be entered. Please note that Hukx calibration uncertainties are lower than those of alternative equipment. These uncertainties are entered in measurement equation (equation is usually Formula 0.1:  $E = U/S$ ), either as an uncertainty in E (zero offsets, directional response) in U (voltage readout errors) or in S (tilt error, temperature dependence, calibration uncertainty).
5. In uncertainty analysis for pyranometers, the location and date of interest is entered. The course of the sun is then calculated, and the direct and diffuse components are estimated, based on a model; the angle of incidence of direct radiation is a major factor in the uncertainty.
6. In uncertainty analysis for modern pyrhemometers: tilt dependence often is so low that one single typical observation may be sufficient.
7. In case of special measurement conditions, typical specification values are chosen. These should for instance account for the measurement conditions (shaded/unshaded, ventilated/unventilated, horizontal/tilted) and environmental conditions (clear sky/cloudy, working temperature range).
8. Among the various sources of uncertainty, some are "correlated"; i.e. present during the entire measurement process, and not cancelling or converging to zero when averaged over time; the off-diagonal elements of the covariance matrix are not zero. Paragraph 5.2 of GUM.
9. Among the various sources of uncertainty, some are "uncorrelated"; cancelling or converging to zero when averaged over time; the off-diagonal elements of the covariance matrix are zero. Paragraph 5.1 of GUM.
10. Among the various sources of uncertainty, some are "not included in analysis"; this applies for instance to non-linearity for pyranometers, because it is already included in the directional error, and the spectral response for pyranometers and pyrhemometers because it is already taken into account in the calibration process.

**Table 6.4.1.1** Preliminary estimates of achievable uncertainties of measurements with pyranometers. For SR01, included in NR01, see the row on “second class” pyranometers. The estimates are based on typical pyranometer properties and calibration uncertainty, for sunny, clear sky days and well-maintained stations, without uncertainty loss due to lack of maintenance and due to instrument fouling. The table specifies expanded uncertainties with a coverage factor of 2 and confidence level of 95 %. Estimates are based on 1 s sampling. IMPORTANT NOTE: there is no international consensus on uncertainty evaluation of pyranometer measurements, so this table should not be used as a formal reference.

<b>Pyranometer class (ISO 9060)</b>	<b>season</b>	<b>latitude</b>	<b>uncertainty minute totals at solar noon</b>	<b>uncertainty hourly totals at solar noon</b>	<b>uncertainty daily totals</b>	
secondary standard	summer	mid-latitude	2.7 %	2.0 %	1.9 %	
		equator	2.6 %	1.9 %	1.7 %	
		pole	7.9 %	5.6 %	4.5 %	
	winter	mid-latitude	3.4 %	2.5 %	2.7 %	
	first class	summer	mid-latitude	4.7 %	3.3 %	3.4 %
			equator	4.4 %	3.1 %	2.9 %
pole			16.1 %	11.4 %	9.2 %	
winter		mid-latitude	6.5 %	4.5 %	5.2 %	
second class (SR01)		summer	mid-latitude	8.4 %	5.9 %	6.2 %
			equator	7.8 %	5.5 %	5.3 %
	pole		29.5 %	21.6 %	18.0 %	
	winter	mid-latitude	11.4 %	8.1 %	9.9 %	

## 6.4.2 Evaluation of pyrgeometer measurement uncertainty

The uncertainty of measurements with pyrgeometers has not yet been formalized. The main ingredients of the uncertainty evaluation for pyrgeometers are:

- Calibration uncertainty, which is in the order of  $\pm 7\%$  ( $k = 2$ ) for upfacing instruments measuring downward longwave irradiance.
- Calibration uncertainty, which is larger for other than upfacing instruments; for downfacing instruments a blackbody calibration seems preferable. Blackbody calibration will result in a lower sensitivity,  $S$ , than WISG traceable calibration.
- Errors due to water deposition at clear nights; these completely block the longwave irradiance exchange between pyrgeometer and may cause the signal  $U/S$  to change from a large negative value ( $-100 \text{ W/m}^2$ ) to around  $0 \text{ W/m}^2$ . Water deposition at clear nights may largely be avoided by using the on-board heater of NR01.
- Errors due to solar offset, which is of the order of  $+15 \text{ W/m}^2$  at  $1000 \text{ W/m}^2$  global horizontal irradiance. This uncertainty is not taken into account in the WISG calibration of the reference instrument.
- Errors due to the choice of the cut-on wavelength of the pyrgeometer. Depending on the atmospheric water content, the pyrgeometer will block a variable percentage of the downward longwave irradiance. This causes an uncertainty of the sensitivity  $S$ . With IR01, this uncertainty is already taken into account in the WISG calibration of the reference instrument.
- Errors due to instrument non-stability. This is now estimated at  $< \pm 1\%$  change per year. The main factor in instrument non-stability is the aging of the pyrgeometer solar blind filter.
- Errors due to the temperature measurement  $T$ . For this a Pt100 or optional  $10 \text{ k}\Omega$  thermistor must be read-out. Required accuracy of the readout is  $\pm 0.2 \text{ }^\circ\text{C}$ , which results in around  $1 \text{ W/m}^2$  uncertainty of the irradiance measurement. To this the uncertainty of the thermistor itself should be added. In measurement of net radiation, in case the upfacing and downfacing instruments are thermally coupled, the temperature measurement (and also its uncertainty) cancels from the equation.

## 6.4.3 Evaluation of net radiometer measurement uncertainty

The WMO Guide Annex 1.B table "operational measurement uncertainty requirements and instrument performance" states under the subject net radiation: Requirements for radiant exposure, daily sums net radiation, as well as achievable measurement uncertainty:

$0.4 \times 10^6 \text{ J/m}^2$ for	$\leq 8 \times 10^6 \text{ J/m}^2$
5 % for	$> 8 \times 10^6 \text{ J/m}^2$

The origin of these figures is unknown. The first impression is that these estimates are achievable under very favorable conditions when the solar component dominates.

# 7 Maintenance and trouble shooting

## 7.1 Recommended maintenance and quality assurance

NR01 can measure reliably at a low level of maintenance in most locations. Usually unreliable measurements will be detected as unreasonably large or small measured values. As a general rule this means that regular visual inspection combined with a critical review of the measured data, preferably checking against other measurements, is the preferred way to obtain a reliable measurement.

Table 7.1.1 Recommended maintenance of NR01. If possible, the data analysis and cleaning (1 and 2) should be done on a daily basis (continued on next page).

Minimum recommended pyranometer sensor maintenance			
	interval	subject	action
1	1 week	data analysis	Compare measured data to maximum possible/ maximum expected solar irradiance and to other measurements nearby (redundant instruments). Analyze patterns in albedo. Analyze patterns of longwave versus solar radiation. Also historical seasonal records can be used as a source for expected values. Analyze upfacing pyranometer nighttime signals. These signals may be negative (down to $-5 \text{ W/m}^2$ on clear windless nights), due to zero offset a. Look for any patterns and events that deviate from what is normal or expected.
2	2 weeks	cleaning	Use a soft cloth to clean the dome of the instrument, persistent stains can be treated with soapy water or alcohol.
3	6 months	inspection	Inspect cable quality, inspect cable glands, inspect mounting position, inspect cable, clean instrument, clean cable, inspect leveling, change instrument tilt in case this is out of specification, inspect mounting connection, inspect interior of dome for condensation. Perform the instrument inversion test and a test of instrument body temperature measurement (chapter 7).
4	2 years	recalibration	recalibration by side-by-side comparison to a higher standard instrument or a recently calibrated instrument in the field

5		lifetime assessment	Judge if the instrument should be reliable for another 2 years, or if it should be replaced.
6	6 years	parts replacement	If applicable/necessary replace the parts that are most exposed to weathering; cable, cable gland, sun screens. NOTE: use Hukx approved parts only.
7		internal inspection	Open instrument and inspect/replace O-rings; dry internal cavity around the circuit board.
8		recalibration	recalibration by side-by-side comparison to a higher standard instrument at the manufacturer or a reference institute. Also recalibrate the temperature sensor.

## 7.2 Trouble shooting

For checking the instrument see the wiring diagram on the product certificate or in chapter 5 of this manual.

### 7.2.1 Check of pyranometers SR01

Table 7.2.1.1 Trouble shooting for SR01 (continued on the next page).

The sensor does not give any signal

Check the electrical resistance of the sensor between the (-) and (+) wire. Use a multimeter at the 200  $\Omega$  range. Measure the sensor resistance first with one polarity, then reverse the polarity. Take the average value. The typical resistance of the wiring is 0.1  $\Omega$ /m. Typical resistance should be the typical sensor resistance of 40 to 60  $\Omega$  plus 1.5  $\Omega$  for the total resistance of two wires (back and forth) of each 5 m. Infinite resistance indicates a broken circuit; zero or a low resistance indicates a short circuit. Check if the sensor reacts to light: put the multimeter at its most sensitive range of DC voltage measurement, typically the  $100 \times 10^{-3}$  VDC range or lower. Expose the sensor to strong light source, for instance a 100 W light bulb at  $1 \times 10^{-1}$  m distance. The signal should read  $> 2 \times 10^{-3}$  V now. Darken the sensor either by putting something over it or switching off the light. The instrument voltage output should go down and within one minute approach 0 V. Check the data acquisition by applying a  $1 \times 10^{-6}$  V source to it in the  $1 \times 10^{-6}$  V range.

The sensor signal is unrealistically high or low

Note that nighttime signals may be negative (down to  $-5 \text{ W/m}^2$  on clear windless nights), due to zero offset a. Check if the pyranometer has clean domes. Check the location of the pyranometer; are there any obstructions that could explain the measurement result. Check the orientation/leveling of the pyranometer. Check if the right calibration factor is entered into the algorithm. Please note that each sensor has its own individual calibration factor, as documented in its calibration certificate. Check if the voltage reading is divided by the calibration factor in review of the algorithm. Check the condition of the wiring at the logger. Check the cable condition looking for cable breaks. Check the range of the data logger; signal can be negative (this could be out of range) or the amplitude could be out of range. Check the data acquisition by applying a  $1 \times 10^{-6}$  V source to it in the  $1 \times 10^{-6}$  V range. Look at the output. Check if the output is as expected. Check the data acquisition by short circuiting the data acquisition input with a 100  $\Omega$  resistor. Look at the output. Check if the output is close to 0  $\text{W/m}^2$ .

The sensor signal shows unexpected variations	<p>Check the presence of strong sources of electromagnetic radiation (radar, radio etc.)</p> <p>Check the condition of the shielding.</p> <p>Check the condition of the sensor cable.</p> <p>Check if the cable is not moving during the measurement.</p>
---	---

The dome shows internal condensation	<p>Arrange to send the sensor back to Hukx for diagnosis.</p>
--------------------------------------	---

## 7.2.2 Check of pyrgeometers IR01

Table 7.2.2.1 Trouble shooting for IR01 (continued on the next page).

The sensor does not give any signal	<p>Check the electrical resistance of the sensor between the (-) and (+) wire. Use a multimeter at the 1000 <math>\Omega</math> range. Measure the sensor resistance first with one polarity, then reverse the polarity. Take the average value. The typical resistance of the wiring is 0.1 <math>\Omega</math>/m. Typical resistance should be the typical sensor resistance of 100 to 400 <math>\Omega</math> plus 1.5 <math>\Omega</math> for the total resistance of two wires (back and forth) of each 5 m. Infinite resistance indicates a broken circuit; zero or a low resistance indicates a short circuit.</p> <p>Check if the sensor reacts to heat: put the multimeter at its most sensitive range of DC voltage measurement, typically the 100 <math>\times 10^{-3}</math> VDC range or lower. Make sure that the sensor is at 25 <math>^{\circ}</math>C or lower. Expose the sensor to a heat source at a short distance from the window of more than 50 <math>^{\circ}</math>C, for instance a heavy (&gt; 5 kg) painted block of metal, or a painted metal container holding hot water. Face the side of the container to avoid condensation of water on the pyrgeometer window. Stir the water to attain homogeneity. A painted surface will act as a blackbody in the far infrared (FIR), irrespective of the visible color. The signal should read positive and &gt; 1 <math>\times 10^{-3}</math> V now. In case of using your hand as a heat source, the signal should be significantly lower.</p> <p>Check the data acquisition by applying a 1 <math>\times 10^{-6}</math> V source to it in the 1 <math>\times 10^{-6}</math> V range.</p>
-------------------------------------	---

The sensor signal is unrealistically high or low	<p>Check if the measurement function has been implemented properly.</p> <p>Please note that each sensor has its own individual calibration factor and constants, as documented in its production certificate.</p> <p>Check the electrical resistance of the Pt100. This should be in the 100 <math>\Omega</math> range. In case of use of the optional 10 k<math>\Omega</math> thermistor it should be in the 104 <math>\Omega</math> range</p> <p>Check if the pyrgeometer has a clean window.</p> <p>Check the location of the pyrgeometer; are there any obstructions/sources that could explain the measurement result.</p> <p>Check the condition of the wiring at the logger.</p> <p>Check the cable condition looking for cable breaks.</p> <p>Check the range of the data logger; signal is usually negative (this could be out of range) or the amplitude could be out of range.</p> <p>Check the data acquisition by applying a 1 <math>\times 10^{-6}</math> V source to it in the 1 <math>\times 10^{-6}</math> V range. Look at the output. Check if the output is as expected.</p> <p>Check the data acquisition by short circuiting the data acquisition input with a 100 to 1000 <math>\Omega</math> resistor. Look at the output. Check if the output is close to 0 W/m<math>^2</math>.</p>
--	--

The sensor signal shows unexpected variations

Check the presence of strong sources of electromagnetic radiation (radar, radio etc.)  
Check the condition of the shielding.  
Check the condition of the sensor cable.  
Check if the cable is not moving during the measurement.

When trouble shooting, inspect the instrument and cables for any damage and check the instrument serial numbers against the certificates supplied with the instrument.

If the trouble shooting steps were followed and further diagnosis is needed, contact Hukx and arrange to send an Excel file containing raw sensor data of a few days of measurement for diagnostics. Include time of day, coordinates, raw voltages and instrument temperature.

### 7.2.3 Check of the Pt100

1. Check the electrical resistance of the Pt100. The resistance between 2 wires at opposite ends of the Pt100 should be in the 100  $\Omega$  range.
2. Check the electrical resistance of the Pt100. The resistance between 2 wires at the same end of the Pt100 should be in the 10  $\Omega$  range or 0.1 Ohm per meter cable.

### 7.2.4 Check of the heater

Check the electrical resistance of the heater. This should be in the 100  $\Omega$  range.

### 7.2.5 Short circuit check between sensors, body and heater

Check the electrical resistance between the sensor wires of all different sensors, heater and instrument body; all these should be higher than  $1 \times 10^6 \Omega$ .

Most multimeters cannot measure in this range, so please use the highest range.

Also check between sensors and heater and between sensors and Pt100.

Check the resistance between sensors wires and body/cable shield;

this should be higher than  $1 \times 10^6 \Omega$ . Check the electrical resistance between

the wires of the heater and the wires of the sensors; this should be higher than

$1 \times 10^6 \Omega$ .

## 7.3 Calibration and checks in the field

A check or calibration of a 4-component net radiometer consists of 2 pyranometer calibrations, 2 pyrgeometer calibrations and calibration of the instrument body temperature sensor.

### 7.3.1 Instrument body temperature sensor test

Compare the reading of the instrument body temperature to an ambient air temperature measurement on a cloudy night (to be verified with upward pyrgeometer measuring an exchange with an absolute value  $|U/S|$  of less than  $20 \text{ W/m}^2$  with a wind speed above  $5 \text{ m/s}$ . Deviations should be less than  $0.5 \text{ }^\circ\text{C}$ .

### 7.3.2 Net-radiometer inversion test

Hukx recommends performing a so-called instrument-inversion-test after installation. This test consists of inverting the instrument orientation (turn around the mounting tube  $180^\circ$ ), and looking at the output signals. For testing pyranometers, perform this test on a clear day, preferably around noon (with the sun high in the sky). For testing of pyrgeometers the test should be repeated at a clear night, without any solar radiation. It is assumed both downwelling and upwelling radiation are the same as measured prior to the test within a time interval of several minutes. For this crude test deviations within  $\pm 10\%$  or  $10 \text{ W/m}^2$  (choose the largest value) between U/S readings of individual sensors may pass as acceptable.

### 7.3.3 Calibration and checks for pyranometers

Recalibration of field pyranometers is typically done by comparison in the field to a reference pyranometer. The applicable standard is ISO 9847 "International Standard- Solar Energy- calibration of field pyranometers by comparison to a reference pyranometer". At Hukx an indoor calibration according to the same standard is used.

Hukx's recommendation for re-calibration: if possible, perform calibration indoors by comparison to an identical reference instrument, under normal incidence conditions.

In case of field comparison; ISO recommends field calibration to a higher class pyranometer. Hukx suggests also allowing use of sensors of the same model and class, because intercomparisons of similar instruments has the advantage that they suffer from the same offsets. It is therefore just as good to compare to pyranometers of the same brand and type as to compare to an instrument of a higher class.

ISO recommends to perform field calibration during several days;

2 to 3 days under cloudless conditions, 10 days under cloudy conditions.

In general this is not achievable. In order to shorten the calibration process

Hukx suggests to allow calibration at normal incidence, using hourly totals near solar noon.

Hukx main recommendations for field intercomparisons are:

1. To take normal incidence as a reference and not the entire day.
2. To take a reference of the same brand and type as the field pyranometer or a pyranometer of a higher class.
3. To connect both instruments to the same electronics, so that electronics errors (also offsets) are eliminated.
4. To mount all instruments on the same platform, so that they have the same body temperature.
5. Assuming that the electronics are independently calibrated, to analyze radiation values at normal incidence radiation (possibly tilting the radiometers to approximately normal incidence); if this is not possible to compare 1-hour totals around solar noon for horizontally mounted instruments.
6. For second class radiometers, to correct deviations of more than  $\pm 10\%$ . Lower deviations should be interpreted as acceptable and should not lead to a revised sensitivity (applicable to pyranometer type SR01 as used in the NR01).
7. For first class pyranometers, to correct deviations of more than  $\pm 5\%$ . Lower deviations should be interpreted as acceptable and should not lead to a revised sensitivity (not applicable to NR01).
8. For secondary standard instruments, to correct deviations of more than  $\pm 3\%$ . Lower deviations should be interpreted as acceptable and should not lead to a revised sensitivity (not applicable to NR01).

### 7.3.4 Calibration and checks for pyrgeometers

Recalibration of field pyrgeometers is typically done by comparison in the field to a reference pyrgeometer. There is no standard for this procedure.

Hukx recommendation for re-calibration: if possible, perform calibration outdoor by comparison to an identical or a higher-class reference instrument, under nighttime as well as daytime conditions. Use nighttime data only to determine S.

Hukx main recommendations for field intercomparisons are:

1. To perform field calibration during several days; 2 to 3 days and if possible under cloudless conditions.
2. To take a reference of the same brand and type as the field pyrgeometer or a pyrgeometer of a higher class.
3. To connect both instruments to the same electronics, so that electronics errors (also offsets) are eliminated.
4. To mount all instruments on the same platform, so that they have the same body temperature.
5. To analyze downward irradiance values at nighttime only to determine S.
6. To analyze the daytime data, independently, and look at the residuals between the calibration reference and calibrated instrument as a function of solar irradiance. The solar offset can serve as a quality indicator of the pyrgeometer filter condition.

## 7.4 Data quality assurance

Quality assurance of global solar irradiance can be done by:

- Analyzing trends in solar irradiance signal.
- Plotting the measured irradiance against mathematically generated expected values.
- Comparing irradiance measurements between sites.
- Analyzing nighttime signals.

Quality assurance of reflected solar irradiance can be done by:

- Analyzing trends albedo over the day and from day to day.
- Comparing reflected irradiance and albedo measurements between sites.
- Analyzing nighttime signals.

Quality assurance of downward longwave can be done by:

- Analyzing trends in longwave irradiance signal.
- Plotting the measured irradiance against mathematically generated expected values.
- Comparing irradiance measurements between sites.
- Analyzing daytime signals against solar irradiance.
- Analyzing nighttime data against zero offsets in the global solar irradiance measurement.

Quality assurance of upward longwave can be done by:

- Plotting the measured irradiance against mathematically generated expected values; upward longwave signal U/S will always be close to zero.
- Comparing irradiance measurements between sites.

The main idea is that one should look out for any unrealistic values.

There are programs on the market that can automatically perform data screening.

See for more information on such a program <https://dama-nl.org/dqms-en>

# 8 RA01 2-component radiometer

## 8.1 Introduction RA01

RA01 is a 2-component radiation sensor, mostly used for scientific-grade energy balance and surface flux studies. It offers separate measurements of solar and longwave radiation. When combined with estimates of solar albedo and of local surface temperature, this instrument can also be used for estimation of net radiation. The advantages of this approach are cost reduction and independence from local surface properties.

RA01 radiometer measures 2 separate components of the surface radiation balance: solar and longwave radiation. The solar radiation sensor is called pyranometer and the longwave sensor is called pyrgeometer. For calculation of sky temperature, it is necessary to compensate for irradiated heat by the pyrgeometer (Stefan-Boltzmann law). A Pt100 temperature sensor is included in RA01's body for that purpose. To prevent deposition of dew, the pyrgeometer has internal heating. A 2-axis leveling assembly is included.

Using RA01 radiometer is easy. It can be connected directly to commonly used data logging systems. The irradiance levels in  $W/m^2$  are calculated by dividing the RA01 outputs, small voltages, by the sensitivities. The longwave irradiance should be corrected using the instrument body temperature. The sensitivities of all sensors are provided with RA01 on its product certificate.

RA01 radiometer has a modular design: it is possible to take the instrument apart and replace or re-calibrate individual sensors. The included 2-axis leveling assembly fits a 1 inch NPS tube (the tube's recommended outer diameter equals  $33.4 \times 10^{-3}$  m). With the RA01 shim, included in RA01's delivery, a  $\frac{3}{4}$  inch NPS tube may also be used.

Suggested use:

- energy balance studies
- surface flux measurements
- climatological networks



Figure 8.11 RA01 2-component radiometer.

## 8.2 Specifications of RA01

RA01 is a 2-component radiometer, consisting of a pyranometer type SR01, a pyrgeometer type IR01, a heater, leveling assembly for x- and y-axis and a Pt100 instrument body temperature sensor.

Pyranometers and pyrgeometers (the latter with additional input of the body temperature measurement) measure the solar and longwave radiation received by a plane surface, in  $W/m^2$ . For compensation of pyrgeometer emission in the longwave calculation and for calculation of sky- temperature, a Pt100 temperature sensor is included in the instrument body. Working completely passive, using a thermopile sensor, the sensors generate a small output voltage proportional to these fluxes. An optional measurand is sunshine duration. RA01 can only be used in combination with a suitable measuring system. The instrument should be used in accordance with the recommended practices of ISO, IEC, WMO and ASTM.

Table 8.2.1 Specifications of RA01 (continued next pages).

<b>RA01 radiometer general specifications</b>	
product type	2-component radiometer
included sensors	1 x ISO 9060 second class pyranometer (see separate specification table for model SR01) 1 x pyrgeometer with 150 ° field of view angle (see separate specification table for model IR01)
leveling	Bubble level and a leveling assembly for x- and y-axis are included.
required sensor power	zero (passive sensor)
temperature sensor	Pt100
heater on pyrgeometer	12 VDC, 1.5 W (see below for details)
rated operating temperature range	-40 to +80 °C
rated operating relative humidity range	0 to 100 %
required readout	2 x differential voltage channel or 2 x single ended voltage channel, input resistance > $10^6 \Omega$ 1 x temperature channel for Pt100
standards governing use of the instrument	ISO/TR 9901:1990 Solar energy -- Field pyranometers -- Recommended practice for use  ASTM G183 - 05 Standard Practice for Field Use of Pyranometers, Pyrhemimeters and UV Radiometers  WMO-No. 8, Guide to Meteorological Instruments and Methods of Observation, seventh edition 2008, paragraph 7.4 "measurement of total and long-wave radiation"

## RA01 radiometer measurands

measurand upfacing pyranometer	global solar radiation
measurand in SI units	irradiance in W/m <sup>2</sup>
measurement function/required programming global solar irradiance	$E_g \downarrow_h = U/S$
measurand upfacing pyranometer	downward longwave radiation*
measurand in SI units	irradiance in W/m <sup>2</sup>
measurement function/required programming downward longwave radiation	$E_l \downarrow = U/S + \sigma \cdot (T + 273.15)^4$
optional measurand upfacing pyrgeometer	sky temperature*
optional measurand in SI units	equivalent blackbody radiative temperature in °C
measurement function/required programming sky temperature	$T_{sky} = (E_l \downarrow / \sigma)^{1/4} - 273.15$
optional measurand upfacing pyranometer	sunshine duration
optional measurand in SI units	sunshine duration in h
measurement function/optional programming sunshine duration	programming according to WMO guide paragraph 8.2.2
measurand Pt100	instrument body temperature $T_{body}$
measurand in SI units	temperature in °C

\*required measurand: instrument body temperature.

## RA01 mounting, cabling, transport

standard cable length (see options)	2 x 5 m
cable diameter	$5.3 \times 10^{-3}$ m
cable replacement	Cable can be removed and installed by the user provided that the cable is sealed at the instrument side against humidity ingress. Consult Hukx for instructions or use Hukx-supplied parts.
instrument mounting	A leveling assembly for x- and y-axis is included. It fits a 1 inch NPS tube (the tube's recommended outer diameter equals $33.4 \times 10^{-3}$ m). Attach mounting tube to leveling assembly using a hex key size 4.0 mm (not included) for bolt size M5. With the RA01 shim, included in RA01's delivery, a $\frac{3}{4}$ inch NPS tube may also be used. This tube's recommended outer diameter equals $26.8 \times 10^{-3}$ m. Tubes are not included.
leveling accuracy	$< 0.6^\circ$ bubble entirely in ring
IP protection class	IP67
gross weight including 2 x 5 m cable	approx. 2 kg
net weight including 2 x 5 m cable	approx. 1 kg
<b>Heating</b>	
heater operation	The heater is not necessarily switched on. The recommended operation is to activate the heater when there is a risk of dew deposition.
required heater power	1.5 W at 12 VDC (The heater is not necessarily active)
heater resistance	95 $\Omega$

## Calibration

calibration traceability solar	to WRR (see SR01 for details)
calibration traceability longwave	to WISG (see IR01 for details)
calibration traceability Pt100	to ITS-90
validity of calibration	Based on experience the instrument sensitivity will not change during storage. During use under exposure to solar radiation the instrument "non-stability" specification is applicable.
recommended recalibration interval	2 years

## Measurement accuracy

uncertainty of the measurement	Statements about the overall measurement uncertainty can only be made on an individual basis. See the chapter on uncertainty evaluation
achievable measurement accuracy	see SR01 and IR01 specifications
temperature sensor accuracy class	Pt100 DIN EN 60751 class A
uncertainty Pt100	$\pm (0.15 \text{ °C} + 0.002 \cdot  T )$

## Versions/options

longer cable, in multiples of 5 m, cable lengths above 20 m in multiples of 10 m	option code = total cable length
internal temperature sensor	measuring the instrument body temperature: version code = T1 for Pt100 DIN class A, version code = T2 for thermistor 10 k $\Omega$ at 25 °C

### 8.3 Dimensions of RA01

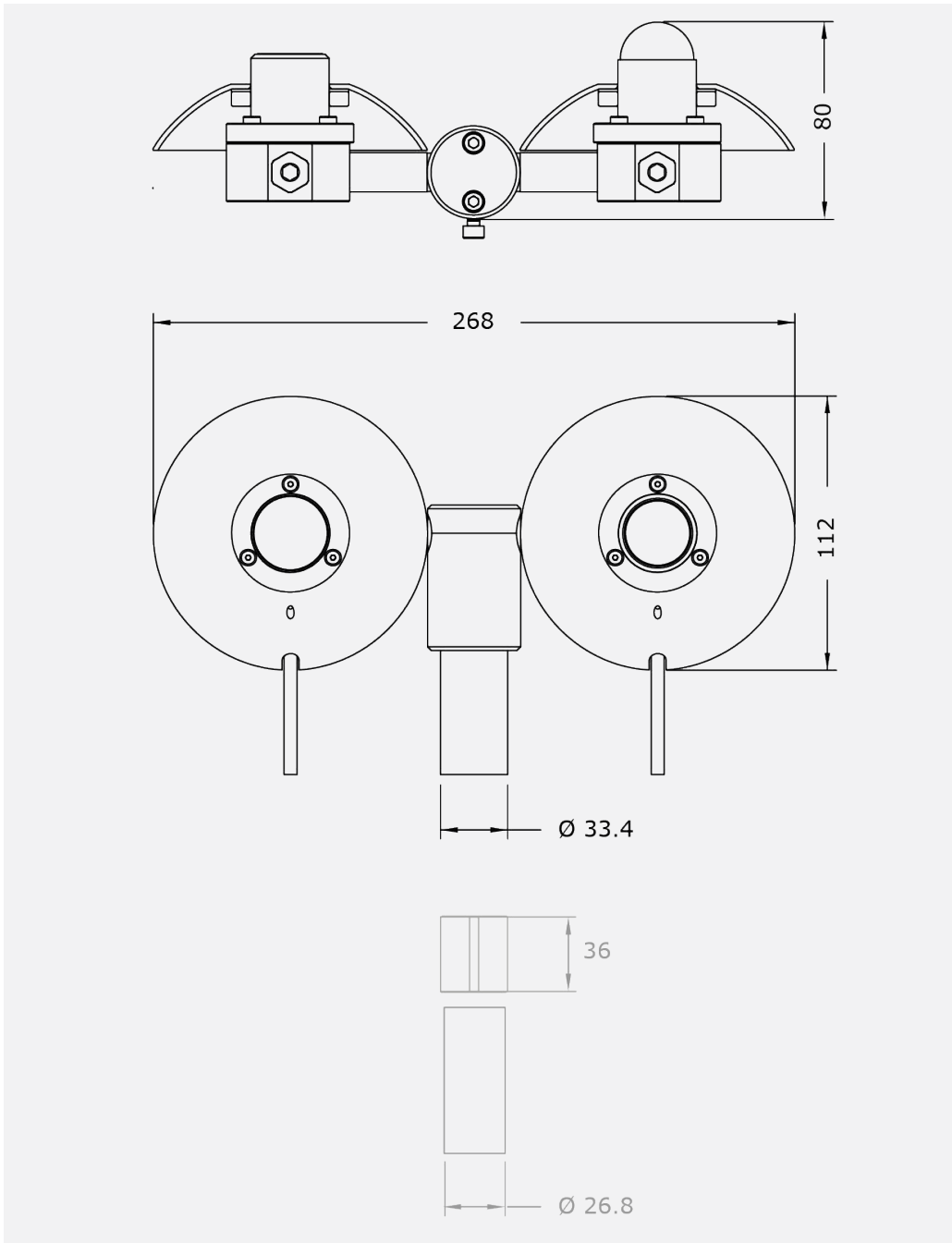

**Figure 8.3.1** Dimensions of RA01 in  $\times 10^{-3}$  m. RA01 fits a 1 inch NPS tube (recommended outer tube diameter is  $33.4 \times 10^{-3}$  m). Alternatively (displayed in gray), RA01 may be mounted on a  $\frac{3}{4}$  inch NPS tube (recommended outer tube diameter is  $26.8 \times 10^{-3}$  m) using RA01's shim.

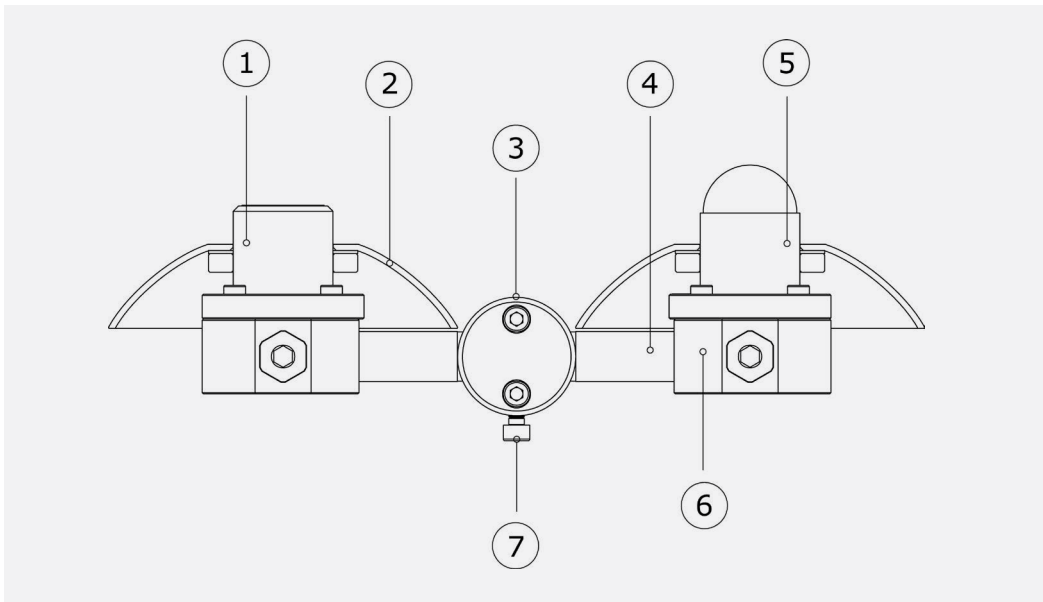

**Figure 8.3.2** Overview of RA01:  
 1. upfacing pyrgeometer  
 2. sun screens  
 3,4. leveling assembly for x- and y-axis  
 5. upfacing pyranometer  
 6. instrument body  
 7. leveling assembly for x- and y-axis

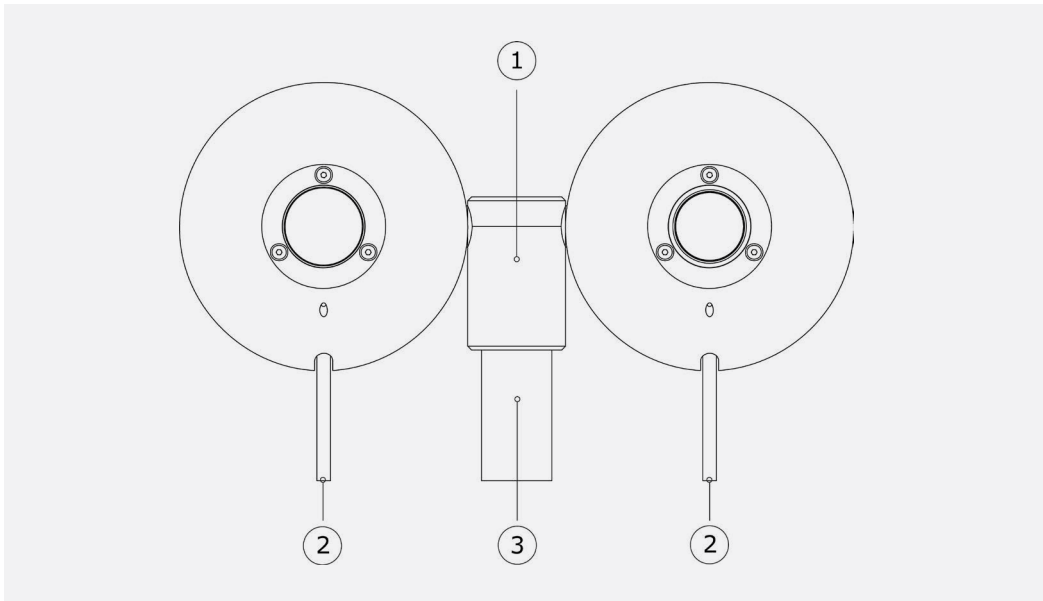

**Figure 8.3.3** Top view of RA01 fitting a 1 inch tube:  
 1. leveling assembly for x- and y-axis  
 2. cables (cable 1 at the left, at pyranometer side, cable 2 at the right, at pyrgeometer side)  
 3. 1 inch mounting tube (not included)

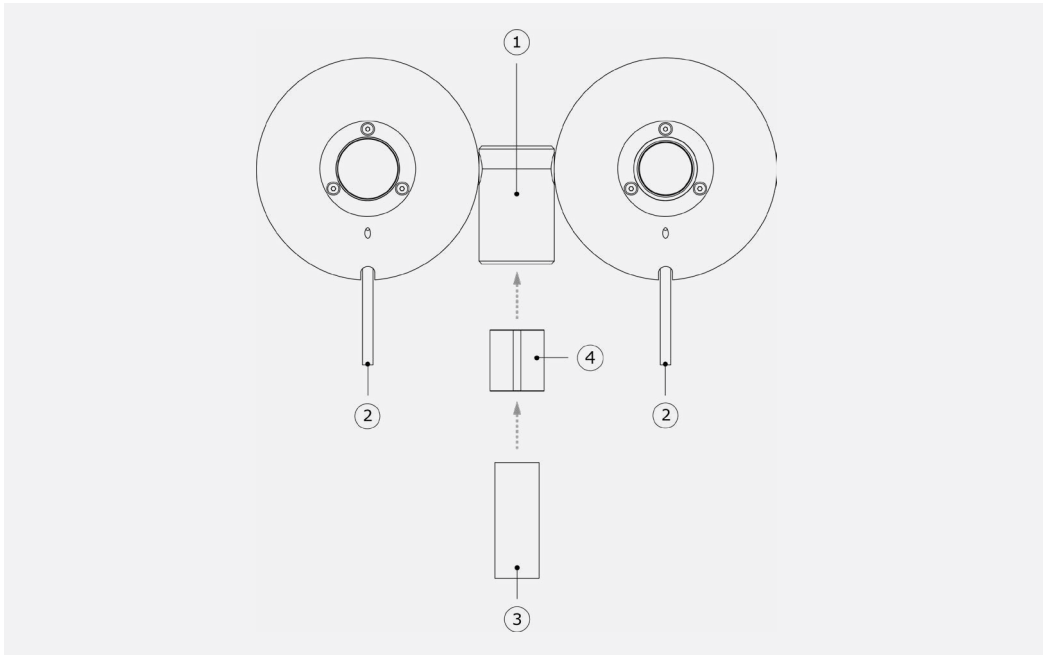

**Figure 8.3.4** Top view of RA01 fitting a 3/4 inch NPS tube (alternative mounting method):  
 1. leveling assembly for x- and y-axis  
 2. cable (cable 1 at the left, at pyranometer side, cable 2 at the right, at pyrgeometer side)  
 3. 3/4 inch mounting tube (not included)  
 4. shim, included with RA01 delivery

## 8.4 Electrical connection of RA01

In order to operate, RA01 should be connected to a measurement system, typically a so-called data logger. RA01 contains passive sensors that do not need any power, however there is an on-board heating resistor in the instrument body, that may be switched on to prevent dew deposition. Cables generally act as a source of distortion, by picking up capacitive noise. We recommend keeping the distance between a data logger or amplifier and the sensor as short as possible. For cable extension, see the appendix on this subject.

NOTE: upfacing sensors measuring downward radiation are indicated by SR01 ↓ and IR01 ↓.

**Table 8.4.1** The electrical connection of the standard RA01 with Pt100. PCB 04 and PCB 05 are internal printed circuit boards. There are two cables, marked cable 1 and cable 2, cable 1 at the pyranometer side, cable 2 at the pyrgeometer side.

connection cable 1			connection cable 2		
PCB04	wire		PCB05	wire	
1	blue	SR01 ↓ [-]	1	brown	heater
2	red	SR01 ↓ [+]	2	red	Pt100 [+]
3	yellow	IR01 ↓ [-]	3	white	Pt100 [+]
4	brown	IR01 ↓ [+]	4	blue	Pt100 [-]
5	gray	not connected	5	green	Pt100 [-]
6	pink	not connected	6	yellow	heater
7	green	not connected		pink	not connected
8	white	not connected		gray	not connected
11	black	shield	10	black	shield

Note 1: the heater is not necessarily connected. In case it is connected, the polarity of the connection is not important.

Note 2: signal wires are insulated from ground wire and from the sensor body. Insulation resistance is tested during production and is larger than  $1 \times 10^6 \Omega$ .

# 9 Appendices

## 9.1 Appendix on cable extension/replacement

The sensor cables can be removed and installed by the user provided that the cables are sealed at the sensor side against humidity ingress. Please consult Hukx for instructions on cable preparation or use Hukx-supplied parts.

NR01 is equipped with two cables. Keep the distance between data logger or amplifier and sensor as short as possible. Cables act as a source of distortion by picking up capacitive noise. In an electrically “quiet” environment the NR01 cable can however be extended without problem to 100 meters. If done properly, the sensor signal, although small, will not significantly degrade because the sensor resistance is very low (so good immunity to external sources) and because there is no current flowing (so no resistive losses).

Cable and connection specifications are summarized below.

NOTE: the body of NR01 contains connector blocks that can be used for the internal connection of a new cable. See the chapter on electrical connections. Usually it is easier to connect a new extended cable inside the instrument body cable than to make a good (weatherproof) connection to an existing cable.

Table 9.1.1 Preferred specifications for cable extension/replacement of NR01.

general	Please consult Hukx for instructions or use Hukx-supplied parts.
cable	8-wire, shielded, with copper conductor
sealing	sealed at the sensor side against humidity ingress
core resistance	$< 0.1 \Omega/m$
outer diameter	5 to $6.5 \times 10^{-3}$ m to fit cable gland. Clamping should be conforming with installations according to UL (Underwriters Laboratories) standards.
length	Cables and wires should be kept as short as possible, in any case, the total cable length should be less than 100 m.
outer sheet	with specifications for outdoor use (for good stability in outdoor applications)
connection	Either solder the new cable core and shield to the original sensor cable, and make a waterproof connection using cable shrink, or use gold plated waterproof connectors. Always connect the cable shield.

## 9.2 Appendix on tools for NR01

Table 9.2.1 Specifications of tools for NR01.

tooling required for sun screen fixation and removal	hex key 2 mm
tooling required for cable gland fixation and removal	spanner size 15 mm
tooling required for wire fixation and removal (internal wiring inside NR01 body)	screwdriver blade width 2 mm
tooling required for pyranometer and pyrgeometer to body connection	hex key 2.5 mm
tooling required for plastic plugs on NR01 body	spanner size 15 or hex key size 6 mm
tooling required for 2-axis leveling assembly	hex key 4 mm

## 9.3 Appendix on spare parts for NR01

- NR01 cable (specify length in multiples of 5 m), sealed at one end (2 cables per instrument)
- cable gland NR01
- O-ring NR01
- shim NR01
- sun screen SCR01
- pyranometer SR01
- pyrgeometer IR01

## 9.4 Appendix on standards for classification and calibration

Both ISO and ASTM have standards on instrument classification and methods of calibration for pyranometers, not for pyrgeometers. The World Meteorological Organization (WMO) has largely adopted the ISO classification system.

Table 9.4.1 Pyranometer standardization in ISO and ASTM.

Standards on instrument classification and calibration	
ISO standard	Equivalent ASTM standard
ISO 9060:1990 Solar energy -- Specification and classification of instruments for measuring hemispherical solar and direct solar radiation	not available Comment: work is in progress on a new ASTM equivalent standard.
Comment: a standard "Solar energy --Methods for testing pyranometer and pyr heliometer characteristics" has been announced in ISO 9060 but is not yet implemented.	not available
ISO 9846:1993 Solar energy -- Calibration of a pyranometer using a pyr heliometer	ASTM G167 - 05 Standard Test Method for Calibration of a Pyranometer Using a Pyr heliometer
ISO 9847:1992 Solar energy -- Calibration of field pyranometers by comparison to a reference pyranometer	ASTM E 824 -10 Standard Test Method for Transfer of Calibration from Reference to Field Radiometers  ASTM G207 - 11 Standard Test Method for Indoor Transfer of Calibration from Reference to Field Pyranometers
ISO 9059:1990 Solar energy -- Calibration of field pyr heliometers by comparison to a reference pyr heliometer.	ASTM E 816 Standard Test Method for Calibration of Pyr heliometers by Comparison to Reference Pyr heliometers.

Unlike pyranometers, pyrgeometers are not subject to a system of classification. At Hukx we distinguish between normal pyrgeometers, like model IR01, and "research grade" pyrgeometers, like IR20 and IR20WS. The term "research grade" is used to indicate that this instrument has the highest attainable specifications.

WMO-No.-8, Guide to Meteorological Instruments and Methods of Observation, seventh edition 2008, table 7.7 gives 3 levels of performance of pyr radiometers. Hukx does not use this classification system because its specifications are not sufficiently clear.

## 9.5 Appendix on calibration hierarchy

### 9.5.1 Calibration hierarchy for pyranometers

The World Radiometric Reference (WRR) is the measurement standard representing the SI unit of irradiance. It was introduced in order to ensure worldwide homogeneity of solar radiation measurements and has been in use since 1980. The WRR was determined from the weighted mean of the measurements of a group of 15 absolute cavity radiometers which were fully characterized. It has an estimated accuracy of 0.3 %. The WMO introduced its mandatory use in its status in 1979.

The worldwide homogeneity of the meteorological radiation measurements is guaranteed by the World Radiation Center in Davos Switzerland, by maintaining the World Standard Group (WSG) which materializes the World Radiometric Reference.

See <https://www.pmodwrc.ch>

The Hukx standard is traceable to an outdoor WRR calibration. Some small corrections are made to transfer this calibration to the Hukx standard conditions: sun at zenith and 1000 W/m<sup>2</sup> irradiance level. During the outdoor calibration the sun is typically at 20 to 40 ° zenith angle, and the total irradiance at a 700 W/m<sup>2</sup> level.

Table 9.5.1.1 Calibration hierarchy for pyranometers.

#### Working standard calibration at PMOD/WRC Davos

Calibration of working standard pyranometers:

Method: ISO 9846, type 1 outdoor. This working standard has an uncertainty "uncertainty of standard". The working standard has been calibrated under certain "test conditions of the standard". The working standard has traceability to WRR world radiometric reference.

#### Correction of (working) standard calibration to standardized reference conditions

Correction from "test conditions of the standard" to "reference conditions" i.e. to normal incidence and 20 °C: Using known (working) standard pyranometer properties: directional, non-linearity, offsets, temperature dependence). This correction has an uncertainty; "uncertainty of correction". At Hukx we also call the working standard pyranometer "standard".

#### Indoor product calibration

Calibration of products, i.e. pyranometers:

Method: according to ISO 9847, Type IIc, which is an indoor calibration.

This calibration has an uncertainty associated with the method.

(In some cases like the BSRN network the product calibration is with a different method; for example again type 1 outdoor).

#### Calibration uncertainty calculation

ISO 98-3 Guide to the Expression of Uncertainty in Measurement, GUM Determination of combined expanded uncertainty of calibration of the product, including uncertainty of the working standard, uncertainty of correction, uncertainty of the method (transfer error).

The coverage factor must be determined; at Hukx we work with a coverage factor  $k = 2$ .

## 9.5.2 Calibration hierarchy of pyrgeometers

Hukx pyrgeometers are traceable to the World Infrared Standard Group (WISG). WISG is composed of a group of pyrgeometers. The calibration hierarchy of Hukx's IR01 is from WISG through Hukx's internal calibration procedures.

The calibration of the IR01 working standard involves outdoor comparison at Hukx of the IR01 working standard to a working standard of a higher level, a pyrgeometer of model IR20 calibrated against the WISG. IR02 pyrgeometers are calibrated using an indoor procedure under an infrared source (blackbody).

The WISG group of instruments is maintained by World Radiation Center (WRC), in Davos, Switzerland. An absolute sky-scanning radiometer provides the absolute longwave irradiance reference. Comparisons between the reference and the WISG are performed on a regular basis to maintain the WISG and supervise its long-term stability. It is essential that these intercomparisons take place under various sky conditions, but the predominant condition is a clear sky, which means that the validity of WISG calibration is a clear-sky spectrum. Typical exchange between pyrgeometer and sky is in the  $-70$  to  $-120$   $W/m^2$ .

Table 9.5.2.1 Calibration hierarchy for pyrgeometers with  $150^\circ$  field of view angle.

### Working standard IR20 calibration at PMOD/WRC Davos

Calibration of working standard IR20 ( $180^\circ$  field of view angle) pyrgeometers traceable to WISG. A typical uncertainty of S is 4.2 % ( $k = 2$ ).

### Correction of (working) standard IR20 calibration to standardized reference conditions

Correction from "test conditions of the standard" to "reference conditions" :  
No corrections are applied. Reference conditions are: horizontal mounting, atmospheric longwave irradiance, clear sky nights,  $20^\circ C$ .

### Outdoor IR02 working standard calibration at Hukx

Calibration of working standard IR02 ( $150^\circ$  degrees field of view angle) pyrgeometer at Hukx.

### Indoor product calibration

Calibration of products, i.e. pyrgeometers of type IR01:  
Method: Calibration according to Hukx internal procedure IRC.  
Indoor side by side comparison to a working standard IR02 pyrgeometer under an infrared blackbody source.  
This calibration has an uncertainty associated with the method.

### Calibration uncertainty calculation

ISO 98-3 Guide to the Expression of Uncertainty in Measurement, GUM Determination of combined expanded uncertainty of calibration of the product, including uncertainty of the working standard, uncertainty of correction, uncertainty of the method (transfer error). The coverage factor must be determined; at Hukx we work with a coverage factor  $k = 2$ .  
Hukx specifies a calibration uncertainty of  $< 7\%$  ( $k = 2$ ).

## 9.6 Appendix on meteorological radiation quantities

A pyranometer measures irradiance. The time integrated total is called radiant exposure. In solar energy radiant exposure is often given in  $W \cdot h/m^2$ . becomes, as stated in the specifications:

**Table 9.6.1** Meteorological radiation quantities as recommended by WMO (additional symbols by Hukx Thermal Sensor). POA stands for Plane of Array irradiance. The term originates from ASTM and IEC standards.

symbol	description	calculation	units	alternative expression	
$E_{\downarrow}$	downward irradiance	$E_{\downarrow} = E_{g\downarrow} + E_l\downarrow$	$W/m^2$		
$H_{\downarrow}$	downward radiant exposure for a specified time interval	$H_{\downarrow} = H_{g\downarrow} + H_l\downarrow$	$J/m^2$	$W \cdot h/m^2$	Change of units
$E_{\uparrow}$	upward irradiance	$E_{\uparrow} = E_{g\uparrow} + E_l\uparrow$	$W/m^2$		
$H_{\uparrow}$	upward radiant exposure for a specified time interval	$H_{\uparrow} = H_{g\uparrow} + H_l\uparrow$	$J/m^2$	$W \cdot h/m^2$	Change of units
$E$	direct solar irradiance normal to the apparent solar zenith angle		$W/m^2$	DNI	Direct Normal Irradiance
$E_0$	solar constant		$W/m^2$		
$E_{g\downarrow h}$	global irradiance; hemispherical irradiance on a specified, in this case, horizontal surface*	$E_{g\downarrow} = E \cos \theta_h + E_{d\downarrow}$	$W/m^2$	GHI	Global Horizontal Irradiance
$E_{g\downarrow t}$	global irradiance; hemispherical irradiance on a specified, in this case, tilted surface*	$E_{g\downarrow} = E \cdot \cos \theta_t + E_{d\downarrow t} + E_r\uparrow_t$ ****	$W/m^2$	POA	Plane of Array
$E_d\downarrow$	downward diffuse solar radiation		$W/m^2$	DHI	Diffuse Horizontal Irradiance
$E_l\uparrow, E_l\downarrow$	upward/downward long-wave irradiance		$W/m^2$		
$E_r\uparrow$	reflected solar irradiance		$W/m^2$		
$E^*$	net irradiance	$E^* = E_{\downarrow} - E_{\uparrow}$	$W/m^2$		
$T_{\text{surface}}$	equivalent blackbody radiative temperature of the surface**		$^{\circ}C$ or $K$		
$T_{\text{sky}}$	equivalent blackbody radiative temperature of the sky**		$^{\circ}C$ or $K$		
SD	sunshine duration		h		

$\theta$  is the apparent solar zenith angle  $\theta_h$  relative to horizontal,  $\theta_t$  relative to a tilted surface

g = global, l = long wave, t = tilted\*, h = horizontal\*

\* distinction horizontal and tilted by Hukx

\*\* T symbols introduced by Hukx,

\*\*\* contributions of  $E_d \downarrow_t$  and  $E_r \uparrow_t$  are  $E_d \downarrow$  and  $E_r \uparrow$  both corrected for the tilt angle of the surface

## 9.7 Appendix on ISO and WMO classification tables

**Table 9.7.1** Classification table for pyranometers per ISO 9060 and WMO.

NOTE: WMO specification of spectral selectivity is different from that of ISO. Hukx conforms to the ISO limits. WMO also specifies achievable accuracies. ISO finds this not to be a part of the classification system because it also involves calibration. Please note that WMO achievable accuracies are for clear days at mid latitudes and that the uncertainty estimate does not include uncertainty due to calibration\*.

### ISO classification\*\* table

ISO class	secondary standard	first class	second class
specification limit			
response time (95 %)	15 s	30 s	60 s
Zero offset a (response to 200 W/m <sup>2</sup> net thermal radiation)	± 7 W/m <sup>2</sup>	± 15 W/m <sup>2</sup>	± 30 W/m <sup>2</sup>
Zero offset b (response to 5 K/h in ambient temperature)	± 2 W/m <sup>2</sup>	± 4 W/m <sup>2</sup>	± 8 W/m <sup>2</sup>
non stability (change per year)	± 0.8 %	± 1.5 %	± 3 %
non linearity (100 to 1 000 W/m <sup>2</sup> )	± 0.5 %	± 1 %	± 3 %
directional response	± 10 W/m <sup>2</sup>	± 20 W/m <sup>2</sup>	± 30 W/m <sup>2</sup>
Spectral selectivity (350 to 1 500 x 10 <sup>-9</sup> m) (WMO 300 to 3 000 x 10 <sup>-9</sup> m)	± 3 %	± 5 %	± 10 %
temperature response (interval of 50 K) **	2 %	4 %	8 %
tilt response (0 to 90° at 1 000 W/m <sup>2</sup> )	± 0.5 %	± 2 %	± 5 %

## Additional WMO specifications

WMO class	high quality	good quality	moderate quality
WMO: achievable accuracy for daily sums*	2 %	5 %	10 %
WMO: achievable accuracy for hourly sums*	3 %	8 %	20 %
WMO: achievable accuracy for minute sums*	not specified	not specified	not specified
WMO: resolution (smallest detectable change)	1 W/m <sup>2</sup>	5 W/m <sup>2</sup>	10 W/m <sup>2</sup>

## conformity testing\*\*\*

ISO 9060	individual instrument only: all specs must comply	group compliance	group compliance
----------	--	------------------	------------------

\* WMO 7.2.1: The estimated uncertainties are based on the following assumptions: (a) instruments are well-maintained, correctly aligned and clean; (b) 1 min and 1 h figures are for clear-sky irradiances at solar noon; (c) daily exposure values are for clear days at mid-latitudes. WMO 7.3.2.5: Table 7.5 lists the expected maximum deviation from the true value, excluding calibration errors.

\*\* At Hukx we use the expression  $\pm 1\%$  instead of a range of 2 %.

\*\*\* an instrument is subject to conformity testing of its specifications. Depending on the classification, conformity compliance can be proven either by group- or individual compliance. A specification is fulfilled if the mean value of the respective test result does not exceed the corresponding limiting value of the specification for the specific category of instrument.

## 9.8 Appendix on definition of pyranometer specifications

Table 9.8.1 Definition of pyranometer specifications.

specification	definition	source
response time (95 %)	time for 95 % response. The time interval between the instant when a stimulus is subjected to a specified abrupt change and the instant when the response reaches and remains within specified limits around its final steady value. The response time is a measure of the thermal inertia inherent in the stabilization period for a final reading.	ISO 9060-1990 WMO 1.6.3
Zero offset a: (200 W/m <sup>2</sup> net thermal radiation)	response to 200 W/m <sup>2</sup> net thermal radiation (ventilated). Hukx assumes that unventilated instruments have to specify the zero-offset in unventilated – worst case – conditions. Zero offsets are a measure of the stability of the zero-point. Zero offset a is visible at night as a negative offset, the instrument dome irradiates in the far infrared to the relatively cold sky. This causes the dome to cool down. The pyranometer sensor irradiates to the relatively cool dome, causing a negative offset. Zero offset a is also assumed to be present during daytime.	ISO 9060-1990
Zero offset b: (5 K/h in ambient temperature)	response to 5 K/h change in ambient temperature. Zero offsets are a measure of the stability of the zero-point.	ISO 9060-1990
non-stability (change per year)	percentage change in sensitivity per year. The dependence of sensitivity resulting from ageing effects which is a measure of the long-term stability.	ISO 9060-1990
non-linearity (100 to 1000 W/m <sup>2</sup> )	percentage deviation from the sensitivity at 500 W/m <sup>2</sup> due to the change in irradiance within the range of 100 W/m <sup>2</sup> to 1000 W/m <sup>2</sup> . Non-linearity has an overlap with directional response, and therefore should be handled with care in uncertainty evaluation.	ISO 9060-1990
directional response	The range of errors caused by assuming that the normal incidence sensitivity is valid for all directions when measuring from any direction a beam radiation whose angle of incidence of radiation, projected normal incidence irradiance is 1000 W/m <sup>2</sup> . Directional response is a measure of the deviations from the ideal "cosine behavior" and its azimuthal variation.	ISO 9060-1990
spectral selectivity (350 to 1500 x 10 <sup>-9</sup> m) (WMO 300 to 3000 x 10 <sup>-9</sup> m)	percentage deviation of the product of spectral absorptance and spectral transmittance from the corresponding mean within the specified spectral range. Spectral selectivity is a measure of the spectral selectivity of the sensitivity.	ISO 9060-1990
temperature response (interval of 50 K)	percentage deviation of the sensitivity due to change in ambient temperature within an interval of 50 K the temperature of the pyrheliometer body.	ISO 9060-1990

tilt response (0 to 90 ° at 1000 W/m <sup>2</sup> )	percentage deviation from the sensitivity at 0 ° tilt (horizontal) due to change in tilt from 0 to 90 ° at 1000 W/m <sup>2</sup> irradiance. Tilt response describes changes of the sensitivity due to changes of the tilt angle of the receiving surface.	ISO 9060-1990
sensitivity	The change in the response of a measuring instrument divided by the corresponding change in the stimulus.	WMO 1.6.3
spectral range	The spectral range of radiation to which the instrument is sensitive. For a normal pyrheliometer this should be in the 0.3 to 3 x 10 <sup>-6</sup> m range. Some pyrheliometers with colored glass windows have a limited spectral range.	Hukx

## 9.9 Appendix on terminology/glossary

Table 9.9.1 Definitions and references of used terms.

term	definition (reference)
solar energy or solar radiation	Solar energy is the electromagnetic energy emitted by the sun. Solar energy is also called solar radiation and shortwave radiation. The solar radiation incident on the top of the terrestrial atmosphere is called extra-terrestrial solar radiation; 97 % of which is confined to the spectral range of (290 to 3 000) x 10 <sup>-9</sup> m. Part of the extra-terrestrial solar radiation penetrates the atmosphere and directly reaches the earth's surface, while part of it is scattered and/or absorbed by the gas molecules, aerosol particles, cloud droplets and cloud crystals in the atmosphere. The former is the direct component, the latter is the diffuse component of the solar radiation. (ref: WMO, Hukx).
hemispherical solar radiation	solar radiation received by a plane surface from a 180 ° field of view angle (solid angle of 2π sr) (ref: ISO 9060)
global solar radiation	The solar radiation received from a 180 ° field of view angle on a horizontal surface is referred to as global radiation. Also called GHI. This includes radiation received directly from the solid angle of the sun's disc, as well as diffuse sky radiation that has been scattered in traversing the atmosphere (ref: WMO). Hemispherical solar radiation received by a horizontal plane surface (ref: ISO 9060).
plane-of-array irradiance	also POA: hemispherical solar irradiance in the plane of a PV array (ref: ASTM E2848 - 13 / IEC 61724)
direct solar radiation	radiation received from a small solid angle centered on the sun's disc, on a given plane (ref: ISO 9060)

terrestrial or longwave radiation	radiation not of solar origin but of terrestrial and atmospheric origin and having longer wavelengths ( $3\ 000$ to $100\ 000 \times 10^{-9}$ m). In case of downwelling $E_{\downarrow}$ , also the background radiation from the universe is involved, passing through the "atmospheric window". In case of upwelling $E_{\uparrow}$ , composed of long-wave electromagnetic energy emitted by the earth's surface and by the gases, aerosols and clouds of the atmosphere; it is also partly absorbed within the atmosphere. For a temperature of $300$ K, 99.99 % of the power of the terrestrial radiation has a wavelength longer than $3\ 000 \times 10^{-9}$ m and about 99 per cent longer than $5\ 000 \times 10^{-9}$ m. For lower temperatures, the spectrum shifts to longer wavelengths. (ref: WMO).
World Radiometric Reference (WRR)	measurement standard representing the SI unit of irradiance with an uncertainty of less than $\pm 0.3$ % (see the WMO Guide to Meteorological Instruments and Methods of Observation, 1983, subclause 9.1.3). The reference was adopted by the World Meteorological Organization (WMO) and has been in effect since 1 July 1980 (ref: ISO 9060).
albedo	ratio of reflected and incoming solar radiation. Dimensionless number that varies between 0 and 1. Typical albedo values are: $< 0.1$ for water, from 0.1 for wet soils to 0.5 for dry sand, from 0.1 to 0.4 for vegetation, up to 0.9 for fresh snow.
angle of incidence	angle of radiation relative to the sensor measured from normal incidence (varies from 0 to $90^{\circ}$ )
zenith angle	angle of incidence of radiation, relative to zenith. Equals angle of incidence for horizontally mounted instruments.
azimuth angle	angle of incidence of radiation, projected in the plane of the sensor surface. Varies from 0 to $360^{\circ}$ . $0^{\circ}$ is by definition the cable exit direction, also called north, east is $+90^{\circ}$ (ASTM G113 - 16).
sunshine duration	sunshine duration during a given period is defined as the sum of that sub-period for which the direct solar irradiance exceeds $120\ \text{W/m}^2$ (ref: WMO)
WISG	World Infrared Standard Group. Group of pyrgeometers, maintained by PMOD Davos Switzerland that forms the reference for calibration of pyrgeometers. WISG is traceable to international standards through an absolute sky scanning radiometer. WISG has been formally recognized by the World Meteorological Organization WMO as "interim WMO Pyrgeometer Infrared Reference".
sky temperature	equivalent blackbody radiative temperature of the sky; i.e. the temperature calculated from pyrgeometer data measuring downwelling longwave radiation, assuming the sky behaves as a blackbody with an emission coefficient of 1
surface temperature	equivalent blackbody radiative temperature of the surface; i.e. the temperature calculated from pyrgeometer data measuring upwelling longwave radiation, assuming the ground behaves as a blackbody with an emission coefficient of 1

## 9.10 Appendix on older NR01 models

Since its product introduction, Hukx has improved some specifications of model NR01. For mounting purposes, current NR01s fit a 1 inch NPS tube, and with the included metal shim, a  $\frac{3}{4}$  inch NPS tube as well.

Earlier NR01's, with serial numbers up to #2782, either did only fit a  $\frac{3}{4}$  inch NPS tube, or, when manufactured and sold as NR01-C, solely a 1 inch tube. The current model NR01 has a width of 268 mm, whereas the earlier model NR01 had a width of 262 mm, as Table 9.10.1 shows.

Table 9.10.1 Differences earlier and latest model NR01.

Differences earlier and latest model NR01			
serial no.	model	fits	width (x 10 <sup>-3</sup> m)
up to #2768	NR01	$\frac{3}{4}$ inch NPS tube	262
up to #2768	NR01-C	1 inch NPS tube	268
#2768 and up	NR01	both 1 inch and $\frac{3}{4}$ inch NPS tubes; the latter with the included shim	268

The current model NR01, having serial numbers of 2768 and higher, fits a 1 inch NPS mounting tube (with an outer tube diameter of  $33.4 \times 10^{-3}$  m) and is delivered with a shim allowing alternative mounting on a  $\frac{3}{4}$  inch NPS tube (with an outer tube diameter of  $26.8 \times 10^{-3}$  m).

## 9.11 EU declaration of conformity

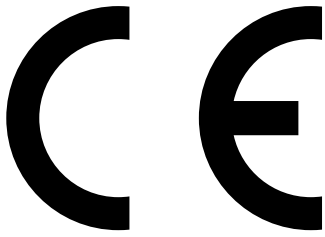

We, Hukseflux Thermal Sensors B.V.  
Delftechpark 31  
2628 XJ Delft  
The Netherlands

in accordance with the requirements of the following directive:

2014/30/EU	The Electromagnetic Compatibility Directive
2011/65/EU, (EU) 2015/863	The Restriction of Hazardous Substances Directive

hereby declare under our sole responsibility that:

Product model	NR01 and RA01
Product type	(Net) radiometer
Brand name	Hukx

has been designed to comply and is in conformity with the relevant sections and applicable requirements of the following standards:

Emission	EN 61326-1(2006)
Immunity	EN 61326-1(2006)
Emission	EN 61000-3-2 (2006)
Emission	EN 61000-3-3 (1995) + A1 (2001) + A2 (2005).
Report	08C01340RPT01, 06 January 2009

Kees VAN DEN BOS  
Director  
Delft, 20 April, 2016

## About Hukx

Hukx is the leading innovator in solar radiation and heat flux sensor technology. We are proud to set the standard in high-accuracy measurement, and to be working at the heart of the energy transition.

Customers worldwide rely on our bestselling pyranometers and heat flux sensors. From sensor design and selection to supply and recalibration, we support you across the entire lifecycle.

Hukx is headquartered in the Netherlands, with locally owned representative sales offices in the USA, Brazil, India, China, Southeast Asia, and Japan.

Let us help you select the best sensor for your application. Get in touch with our experts today via: [info@hukx.com](mailto:info@hukx.com)

© Hukx

v2505

We reserve the right to change specifications without prior notice.

[www.hukx.com](http://www.hukx.com)

**HUKX**