

HUKX

Sensor
Technology

User manual
Research grade
pyrgeometers

**IR20
IR20WS**

Warning statements



Putting more than 12 Volt across the sensor wiring can lead to permanent damage to the sensor.



Do not use "open circuit detection" when measuring the sensor output.

Contents

Introduction	5
1 Ordering and checking at delivery	8
1.1 Ordering IR20	8
1.2 Included items	8
1.3 Quick instrument check	9
2 Instrument principle and theory	10
2.1 Pyrgeometer functionality	10
2.2 Solar and longwave radiation	10
2.3 IR20 pyrgeometer design	12
2.4 Typical measurement results	13
2.5 Optional heating	13
2.6 Optional shading	14
2.7 Use as a net radiation sensor	14
3 Specifications of IR20 and IR20WS	15
3.1 Specifications of IR20 and IR20WS	15
3.2 Dimensions of IR20	20
4 Standards and recommended practices for use	21
4.1 Site selection and installation	22
4.2 Installation of the sun screen	23
4.3 Electrical connection	24
4.4 Requirements for data acquisition/amplification	25
5 Making a dependable measurement	26
5.1 The concept of dependability	26
5.2 Reliability of the measurement	27
5.3 Speed of repair and maintenance	28
5.4 Uncertainty evaluation	28
6 Maintenance and trouble shooting	30
6.1 Recommended maintenance and quality assurance	30
6.2 Trouble shooting	32
6.3 Calibration and checks in the field	33
6.4 Data quality assurance	33
7 Appendices	34
7.1 Appendix on cable extension/replacement	34
7.2 Appendix on tools for IR20	35
7.3 Appendix on spare parts for IR20	35
7.4 Appendix on standards for classification and calibration	35
7.5 Appendix on calibration hierarchy	36
7.6 Appendix on meteorological radiation quantities	38
7.7 Appendix on terminology/glossary	39
7.8 EU declaration of conformity	41

List of symbols

quantities	symbol	unit
voltage output	U	V
sensitivity	S	V/(W/m ²)
sensitivity	S ₀	V/(W/m ²)
at reference conditions		
temperature	T	°C
equivalent blackbody	T	°C
radiative temperature		
electrical resistance	R _e	Ω
longwave irradiance	E	W/m ²
Stefan–Boltzmann		
constant (5.67 x 10 ⁻⁸)	σ	W/(m ² ·K ⁴)
temperature coefficient	a	1/°C ²
temperature coefficient	b	1/°C
temperature coefficient	c	-

(see also appendix 7.6 on meteorological quantities)

subscripts

sky	relating to the atmosphere
surface	relating to the ground surface
ambient	relating to ambient air
body	relating to the instrument body
sensor	relating to the sensor

Introduction

IR20 is a research-grade pyrgeometer suitable for high-accuracy longwave irradiance measurement in meteorological and climatological applications. Thanks to Hukx's technological innovation, IR20 is offered at a significantly lower price level than competing models of the same performance level. IR20 can measure during both day and night. In the absence of solar radiation, model IR20WS measures with even higher accuracy due to its wider spectral range.

IR20 measures the longwave or far-infrared radiation (FIR) received by a plane surface, in W/m^2 , from a 180° field of view angle. In meteorological terms, pyrgeometers measure "downward and upward longwave irradiance" (WMO definition). Longwave radiation refers to the portion of atmospheric radiation that is not emitted by the sun. While the spectral range of longwave radiation is not standardized, a practical cut-on is in the range of 4 to 5×10^{-6} m. IR20 features a dome with a solar-blind filter with a cut-on at 4.5×10^{-6} m, making it suitable for both day and night observations.

Model IR20WS has a wide spectral range with a cut-on at 1.0×10^{-6} m. It offers superior accuracy during nighttime, when solar radiation is absent.

The main purpose of a pyrgeometer is to measure longwave radiation. As secondary measurands, the sky temperature T_{sky} and the equivalent surface temperature $T_{surface}$ can be measured. Both are so-called equivalent blackbody temperatures, i.e. temperatures calculated from pyrgeometer data, assuming the source behaves as a blackbody with an emission coefficient of 1.

IR20 & IR20WS design & benefits

- **breakthrough pricing:** High performance at a significantly lower price level, as a result of Hukx's technological innovation.
- **temperature dependence correction via measurement function:** Far more accurate than internal temperature compensation, especially at extreme temperatures. Every pyrgeometer is supplied with temperature coefficients to enter into the equation.
- **high sensitivity:** With sufficient input signal, a typical data logger no longer significantly contributes to measurement uncertainty.
- **low thermal resistance of the sensor:** Unlike competing designs, IR20 requires no major correction for temperature differences between the pyrgeometer body and sensor surface.
- **fast response time (3 s):** Ideal for measurements on moving platforms, such as aircraft and buoys.
- **on-board heater:** Prevents condensation on the pyrgeometer dome, which can cause very large measurement errors.
- **spectral data:** Instrument cut-on wavelength (5%) and two 50% transmission points are displayed on the product certificate for individual sensors.

Operation

Using IR20 is easy. It can be connected directly to commonly used data logging systems. The irradiance in W/m^2 is calculated by dividing the IR20 output, a small voltage, by the sensitivity and taking in account the irradiated heat by the sensor itself (Planck's law). The sensitivity is provided with IR20 on its calibration certificate. Please note that the IR20 sensitivity is corrected for temperature dependence in the measurement equation by using 3 additional constants. These coefficients are provided as well.

The central measurement equation governing IR20 is:

$$E = U / (S_0 \cdot (a \cdot T^2 + b \cdot T + c)) + \sigma \cdot (T + 273.15)^4 \quad (\text{Formula 0.1})$$

$$S = S_0 \cdot (a \cdot T^2 + b \cdot T + c) \quad (\text{Formula 0.2})$$

The instrument should be used in accordance with the recommended practices of WMO. More about the instrument principle, theory and specifications can be found in the following chapters.

Pyrgeometers are not subject to a classification standard. Calibration of pyrgeometers is usually traceable to the World Infrared Standard Group (WISG). This calibration takes into account the spectral properties of typical downward longwave radiation. As an option, calibration can be made traceable to a blackbody and the International Temperature Scale of 1990 (ITS-90). This alternative calibration is appropriate for measurements of upward longwave radiation (IR20 facing down).

See the specific paragraph in this manual about calibration and uncertainty assessment for more information.

This manual is intended for users of both IR20 and IR20WS. The specifications of IR20WS are identical to IR20's except for its spectral range.



Figure 0.1 IR20 research grade pyrgeometer with its sun screen removed.

Options

- longer cable, in multiples of 5 m

Suggested use

- climatological networks
- extreme climates (polar/tropical)
- moving platforms (aircraft, buoys)
- uncertainty assessment (IR20 + IR20WS)
- calibration reference (IR20WS)

See also

- [the making of IR20](#) documented
- Pyrometers are often used in combination with pyranometers for solar radiation (shortwave) measurement. View our complete [product range of solar sensors](#).
- [IR02 pyrometer](#) for lower accuracy measurements
- [NR01](#) 4-component net radiometer employing 2 pyrometers similar to IR02



Figure 0.2 IR20WS research grade pyrometer.

1 Ordering and checking at delivery

1.1 Ordering IR20

The standard configuration of IR20 is with 5 meters cable and a connector.

Common options are:

- longer cable (in multiples of 5 m). Specify total cable length
- five silica gel bags in an air-tight bag for IR20 desiccant holder.
Specify order number DC01
- optional calibration to blackbody (ITS-90)
- IR20WS for the special wide spectrum model of IR20

1.2 Included items

Arriving at the customer, the delivery should include:

- pyrgeometer IR20 or IR20WS
- cable of the length as ordered with connector
- sun screen
- product certificate matching the instrument serial number
- calibration certificate matching the instrument serial number
- temperature dependence report
- any other options as ordered

Please store the certificates in a safe place.

1.3 Quick instrument check

A quick test of the instrument can be done by using a simple hand held multimeter and a thermal source.

1. Check the electrical resistance of the sensor between the green (-) and white (+) wire. Use a multimeter at the 1000 Ω range. Measure the sensor resistance first with one polarity, than reverse the polarity. Take the average value. The typical resistance of the wiring is 0.1 Ω /m. Typical resistance should be the typical sensor resistance of 5 to 50 Ω plus 1.5 Ω for the total resistance of two wires (back and forth) of each 5 m. Infinite resistance indicates a broken circuit; zero or a low resistance indicates a short circuit.
2. Check if the sensor reacts to heat: put the multimeter at its most sensitive range of DC voltage measurement, typically the 100×10^{-3} VDC range or lower. Make sure that the sensor is at 25 $^{\circ}\text{C}$ or lower. Expose the sensor to a heat source at a short distance from the window of more than 50 $^{\circ}\text{C}$, for instance a heavy (> 5 kg) painted block of metal, or a painted metal container holding hot water. Face the side of the container to avoid condensation of water on the pyrgeometer window. Stir the water to attain homogeneity. A painted surface will act as a blackbody in the far infrared (FIR), irrespective of the visible color. The signal should read positive and $> 1 \times 10^{-3}$ V now. In case of using your hand as a heat source, the signal should be significantly lower.
3. Remove the sun screen (see chapter on installation of the sun screen). Inspect the bubble level.
4. Check the electrical resistance of the thermistor. This should be in the 10^4 Ω range.
5. Check the electrical resistance of the heater. This should be in the 100 Ω range.
6. Inspect the instrument for any damage.
7. Inspect if the humidity indicator is blue. Blue indicates dryness. The color pink indicates it is humid: in the latter case replace the desiccant (see chapter on maintenance).

2 Instrument principle and theory

2.1 Pyrgeometer functionality

IR20's scientific name is pyrgeometer. IR20 measures the longwave or far infrared (FIR) radiation received by a plane surface, in W/m^2 , from a 180° field of view angle. In meteorological terms pyrgeometers are used to measure "downward and upward longwave irradiance" (WMO definition).

As secondary measurands, the sky temperature T_{sky} and the equivalent surface (ground) temperature $T_{surface}$ can be measured. Both are so-called equivalent blackbody radiative temperatures, i.e. temperatures calculated from the pyrgeometer measurement assuming these are uniform-temperature blackbodies with an emission coefficient of 1.

2.2 Solar and longwave radiation

Longwave radiation is the part of the radiation budget that is not emitted by the sun. The spectral range of the longwave radiation is not standardized. A practical cut-on is in the range of 4 to 5×10^{-6} m (see Figure 2.2.1). In meteorology, solar- and longwave radiation are typically measured as separate parameters. The instrument to measure solar radiation is called pyranometer.

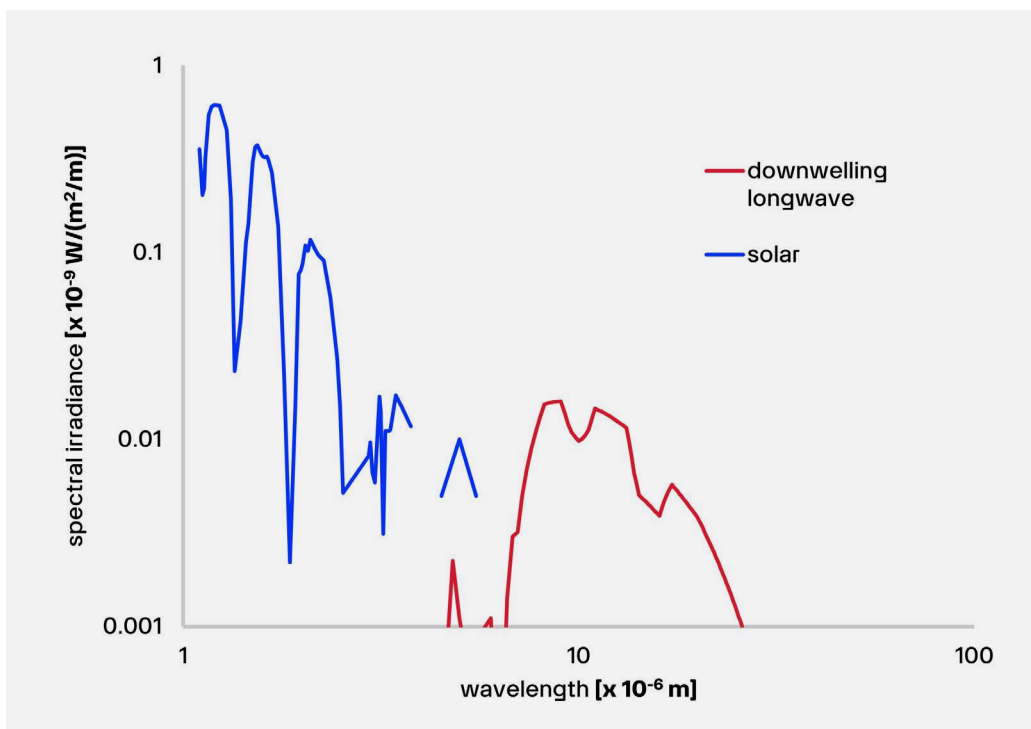

Figure 2.2.1 Atmospheric radiation as a function of wavelength plotted along two logarithmic axes to highlight the longwave radiation. Longwave radiation is mainly present in the 4 to 50×10^{-6} m range, whereas solar radiation is mainly present in the 0.3 to 3×10^{-6} m range. In practice, the two are measured separately using pyrgeometers and pyranometers.

In the longwave spectrum, the sky can be seen as a temperature source; colder than ground-level ambient air temperature, with its lowest temperatures at zenith, getting warmer (closer to ambient air temperature) at the horizon. The uniformity of this longwave source is much better than that in the range of the solar spectrum, where the sun is a dominant contributor. The "equivalent blackbody" temperature, as a function of zenith angle, roughly follows the same pattern independent of the exact sky condition (cloudy or clear). This explains why for pyrgeometers the directional response is not very critical.

The downwelling longwave radiation essentially consists of several components:

1. low-temperature radiation from the universe, filtered by the atmosphere.
The atmosphere is transparent for this radiation in the so-called atmospheric window (roughly the 10 to 15 x 10⁻⁶ m wavelength range).
2. higher temperature radiation emitted by atmospheric gasses and aerosols.
3. in presence of clouds or mist, the low-temperature radiation from the universe is almost completely blocked by the water droplets. The pyrgeometer then receives the radiation emitted by the water droplets.

The spectral distribution of longwave irradiance varies significantly as a function of the source composition. A pyrgeometer is relatively insensitive to these variations, but all the same blackbody calibration tends to differ from WISG calibration by up to 5%. In addition, there may be effects that are uncompensated for in the calibration (for instance related to atmospheric water vapor content) in the 5 to 10 W/m² range. These effects are still under investigation by the international scientific community. Comparison between IR20 and IR20WS may serve to investigate this effect.

Upwelling longwave irradiance is measured with downfacing instruments. These are presumably looking directly at the surface (absorption and emission of the atmosphere is low over a short distance of around 2 m), which behaves like a normal blackbody. Hukx suggests calibrating downfacing instruments against a blackbody rather than having WISG as a reference.

2.3 IR20 pyrgeometer design

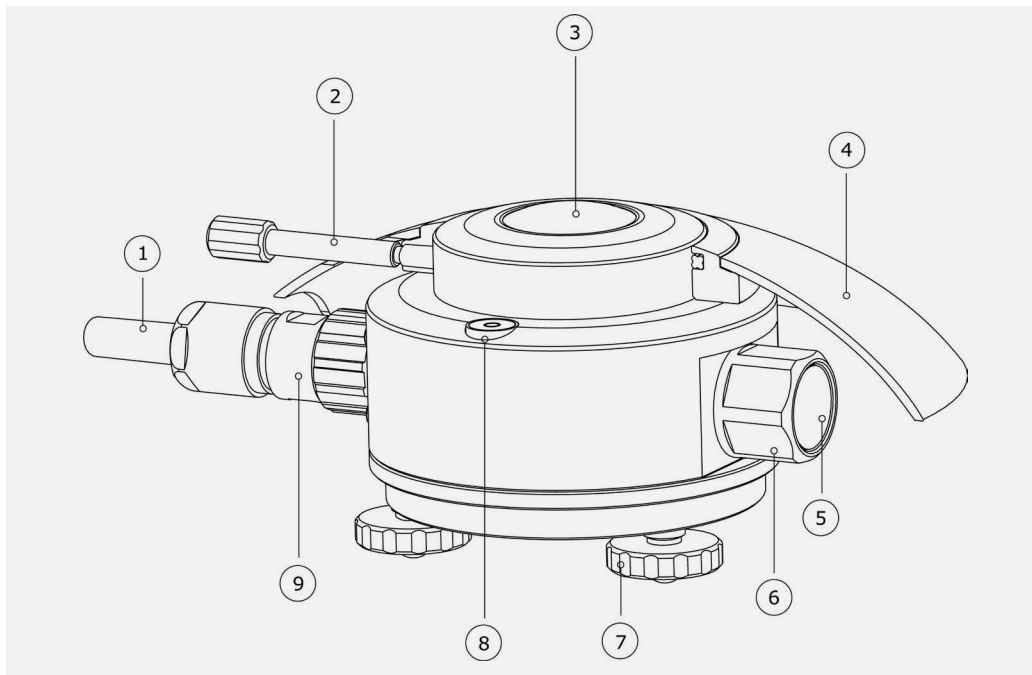

Figure 2.31 Overview of IR20 pyrgeometer:

1. cable
(standard length 5 meters,
optional longer cable)
2. fixation of sun screen
3. dome with solar blind filter
4. sun screen
5. humidity indicator
6. desiccant holder
7. levelling feet
8. bubble level
9. connector

By definition a pyrgeometer should not measure solar radiation, and in the longwave have a spectral selectivity that is as "flat" as possible.

In an irradiance measurement by definition the response to "beam" radiation varies with the cosine of the angle of incidence; i.e. it should have full response when the radiation hits the sensor perpendicularly (normal to the surface, 0 ° angle of incidence), zero response when the source is at the horizon (90 ° angle of incidence, 90 ° zenith angle), and 50 % of full response at 60 ° angle of incidence.

A pyrgeometer should have a so-called "directional response" (older documents mention "cosine response") that is as close as possible to the ideal cosine characteristic.

In order to attain the proper directional and spectral characteristics, a pyrgeometer's main components are:

- a thermal sensor with black coating. It has a flat spectrum covering the 0.3 to 50×10^{-6} m range, and has a near-perfect directional response. The coating absorbs all longwave radiation and, at the moment of absorption, converts it to heat. The heat flows through the sensor to the sensor body. The thermopile sensor generates a voltage output signal that is proportional to the irradiance exchange between sensor and source. The sensor not only absorbs, but also irradiates heat as a blackbody.
- a silicon dome. This dome limits the spectral range from 1.0 to 42×10^{-6} m (cutting off the part below 1.0×10^{-6} m), while preserving the 180 ° field of view angle. Another function of the dome is that it shields the thermopile sensor from the environment (convection, rain).
- a solar blind interference coating deposited on the dome (not for model IR20WS): this coating limits the spectral range. It now becomes 4.5 to 42×10^{-6} m (cutting off the part below 4.5×10^{-6} m).

Pyrgeometers can be manufactured to different specifications and with different levels of verification and characterization during production. Hukx also manufactures lower accuracy pyrgeometers; see our pyrgeometer model [IR02](#).

Model IR20 has a dome with a solar blind filter with a cut-on at 4.5×10^{-6} m, making it suitable for day- and night observations. Model IR20WS has a wide spectral range with a cut-on at 1.0×10^{-6} m. It offers a superior accuracy under night-time conditions, when solar radiation is absent. See also the appendix on uncertainty evaluation.

2.4 Typical measurement results

Please note that the signal generated by an upfacing pyrgeometer usually has a negative sign. The most important factors determining downward longwave irradiance are:

- ambient air temperature
- sky condition/cloud cover
- atmospheric moisture content

Table 2.4.1 Expected pyrgeometer output U/S at different ambient air temperatures, T_{ambient} , and at different cloud conditions. Under clear sky conditions the U/S is around -100 W/m^2 while under cloudy conditions it will be close to 0 W/m^2 . Also calculated: the sky temperature, T_{sky} , and the longwave downward irradiance E.

Expected pyrgeometer output conditions				
T_{ambient}	sky condition	$U/(S_0 \cdot (a \cdot T^2 + b \cdot T + c))$	T_{sky}	E
[°C]	[cloudy], [clear]	[W/m ²]	[°C]	[W/m ²]
-20	cloudy	0	-20	232
-20	clear sky	-100	-53	132
0	cloudy	0	+0	314
0	clear sky	-100	-24	214
+30	cloudy	0	+30	477
+30	clear sky	-100	+12	377

2.5 Optional heating

A low-power heater is located in the body of the pyrgeometer. The heater is not necessarily switched on; recommended operation is to activate the heater when there is a risk of dew deposition.

2.6 Optional shading

One of the larger errors in the daytime measurement of downwelling longwave irradiance is the offset caused by solar radiation; the "solar offset". Errors due to solar offset, are of the order of + 10 W/m² at 1000 W/m² global horizontal irradiance. For ultra-high accuracy measurements this offset can be reduced by around 60 % by "shading", which means preventing the direct radiation to reach the instrument. Shading is typically done by using a shading disk on a solar tracker.

2.7 Use as a net radiation sensor

Two pyrgeometers mounted back to back may be used to measure net longwave radiation. Net longwave radiation is defined as downwelling minus upwelling longwave irradiance. In case the two instruments are thermally coupled, the body temperatures of the instruments are identical. In that case, the body temperature cancels from the equation for the net radiation. However for calculation of sky temperature and surface temperature the instrument temperature still needs to be measured.

3 Specifications of IR20 and IR20WS

3.1 Specifications of IR20 and IR20WS

IR20 research grade pyrgeometer measures the longwave irradiance received by a plane surface, in W/m^2 , from a 180° field of view angle. In meteorological terms IR20 measures downward and upward longwave irradiance. Working completely passive, using a thermopile sensor, IR20 generates a small output voltage proportional to the radiation balance between the instrument and the source it faces. It can only be used in combination with a suitable measurement system. The instrument is not subject to classification. It should be used in accordance with the recommended practices of WMO. IR20 measures during both day and night. In the absence of solar radiation IR20WS offers a higher accuracy because of its wider spectral range. For ultra-high accuracy measurements the user should consider to use the incorporated heater and should consider "shading" the instrument during daytime.

Table 3.1.1 Specifications of IR20 and IR20WS (continued on next pages).

IR20 & ir20ws specifications	
measurands	
measurand	longwave radiation
measurand in SI radiometry units	longwave irradiance in W/m^2
optional measurand	sky temperature
optional measurand	surface temperature
ir20 versus ir20ws: spectral range and use	
spectral range IR20	4.5* to 42×10^{-6} m (* nominal, see product certificate for individual value)
spectral range IR20WS	1.0 to 50×10^{-6} m (based on typical material properties only)
IR20WS restrictions for use	only in the absence of solar radiation
solar offset (IR20 only, not specified for IR20WS)	< $10 W/m^2$ (at $1000 W/m^2$ global horizontal irradiance on the dome)

Main specifications

field of view angle	180 °
directional response	cosine
response time (95 %)	3 s
sensitivity (nominal)	$17 \times 10^{-6} \text{ V}/(\text{W}/\text{m}^2)$
sensitivity range	10 to $25 \times 10^{-6} \text{ V}/(\text{W}/\text{m}^2)$
rated operating temperature range	-40 to +80 °C
temperature dependence	$< \pm 0.4 \%$ (-30 to +50 °C) using the measurement function
temperature sensor	10 k Ω thermistor
required sensor power	zero (passive sensor)
heater	12 VDC, 1.5 W (see below for details)
standard cable length	5 m

Additional specifications

zero offset b (response to 5 K/h change in ambient temperature)	$< \pm 2 \text{ W}/\text{m}^2$
non-stability	$< \pm 1 \%$ change per year
non-linearity	$< \pm 0.5 \%$ (100 to 300 W/m^2 , relative to 200 W/m^2 sensor to source exchange)
measurement range	-1000 to +1000 W/m^2 (sensor to source exchange: $U/(S_0 \cdot (a \cdot T^2 + b \cdot T + c))$)
tilt dependence	$< \pm 0.5 \%$ (0 to 90 ° at 300 W/m^2)
sensor resistance range	5 to 50 Ω
expected voltage output	application for outdoor measurement of downward longwave irradiance: -7.5 to $7.5 \times 10^{-3} \text{ V}$

measurement function/required programming	$E = U/(S_0 \cdot (a \cdot T^2 + b \cdot T + c)) + \sigma \cdot (T + 273.15)^4$
measurement function/optional programming for sky temperature	$T_{\text{sky}} = (E_{\downarrow}/\sigma)^{1/4} - 273.15$
measurement function/optional programming for surface temperature	$T_{\text{surface}} = (E_{\uparrow}/\sigma)^{1/4} - 273.15$
required readout	1 differential voltage channel or 1 single ended voltage channel, input resistance > 10 ⁶ Ω 1 temperature channel

Standards

standard governing use of the instrument	WMO-No. 8, Guide to Meteorological Instruments and Methods of Observation, seventh edition 2008, paragraph 7.4 "measurement of total and long-wave radiation"
--	---

Mounting, cabling, transport

chassis connector	M16 panel connector, male thread, 10-pole
chassis connector type	HUMMEL AG 7.840.200.000 panel connector, front mounting, short version
cable connector	M16 straight connector, female thread, 10-pole
cable connector type	HUMMEL AG 7.810.300.00M straight connector, female thread, for cable diameter 3 to 6 x 10 ⁻³ m, special version
connector protection class	IP67 / IP69 K per EN 60 529 (connected)
cable diameter	5.3 x 10 ⁻³ m
cable replacement	Replacement cables with connector can be ordered separately from Hukx.
instrument mounting	2 x M5 bolt at 65 x 10 ⁻³ m center-to-center distance on north-south axis, or 1 x M6 bolt at the center of the instrument, connection from below under the bottom plate of the instrument
leveling	bubble level and adjustable levelling feet are included
leveling accuracy	< 0.1 ° bubble entirely in ring

desiccant	two bags of silica gel, 0.5 g, 35 x 20 mm
humidity indicator	blue when dry, pink when humid
IP protection class	IP67
gross weight including 5 m cable	approx. 1 kg
net weight including 5 m cable	approx. 0.5 kg

Heating

heater operation	The heater is not necessarily switched on; recommended operation is to activate the heater when there is a risk of dew deposition.
required heater power	1.5 W at 12 VDC
heater resistance	95 Ω
steady state zero offset caused by heating	0 W/m ²

Calibration

calibration traceability	to WISG
optional traceability	to blackbody (ITS-90)
calibration hierarchy	from WISG through Hukx internal calibration procedure involving outdoor comparison to a reference pyrgeometer
calibration method	outdoor comparison to a reference pyrgeometer
calibration uncertainty	< 6 % (k = 2)
recommended recalibration interval	2 years
reference conditions	horizontal mounting, atmospheric longwave irradiance, clear sky nights, 20 °C
validity of calibration	Based on experience the instrument sensitivity will not change during storage. During use under exposure to solar radiation the instrument "non-stability" specification is applicable. Hukx recommends ITS-90 traceable calibration for upward longwave irradiance measurement.

characterization of the dependence of sensitivity to temperature

Temperature coefficients a, b and c of the measurement equation are determined in an independent experiment, and reported on the product certificate.

Measurement accuracy

uncertainty of the measurement

Statements about the overall measurement uncertainty can only be made on an individual basis. See the chapter on uncertainty evaluation.

achievable uncertainty (95 % confidence level)
daily totals

± 8 % (Hukx's own estimate)

Versions/Options

longer cable, in multiples of 5 m

option code = total cable length

calibration

optional to blackbody (ITS-90)

Accessories

bags of silica gel for desiccant

set of 5 bags in an air-tight bag
option code = DC01

3.2 Dimensions of IR20

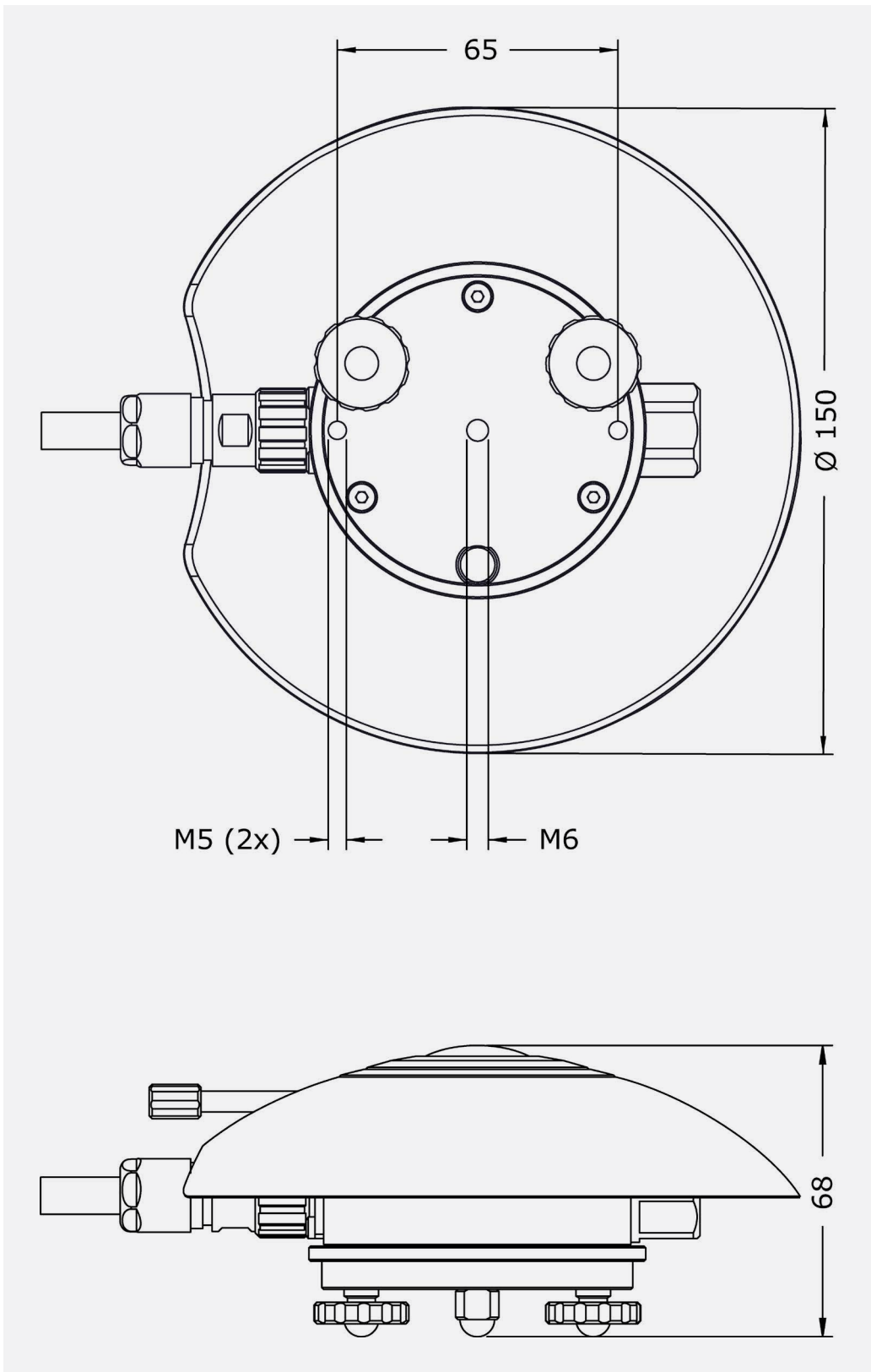

Figure 3.2.1 Dimensions of IR20 and IR20WS in 10^{-3} .

4

Standards and recommended practices for use

Pyrgeometers are not subject to standardization.

The World Meteorological Organization (WMO) is a specialized agency of the United Nations. It is the UN system's authoritative voice on the state and behavior of the earth's atmosphere and climate. WMO publishes WMO-No. 8; Guide to Meteorological Instruments and Methods of Observation, in which paragraph 7.4 covers "measurement of total and long-wave radiation".

For ultra-high accuracy measurements, the following manual may serve as a reference: Baseline Surface Radiation Network (BSRN) Operations Manual, Version 2.1, L. J. B. McArthur, April 2005, WCRP-121, WMO/TD-No. 1274. This manual also includes chapters on installation and calibration.

4.1 Site selection and installation

Table 4.1.1 Recommendations for installation of pyrgeometers.

location	The horizon should be as free from obstacles as possible. Ideally there should be sources of longwave irradiance between the course of the sun and the instrument, only free sky.
mechanical mounting/thermal insulation	Preferably use connection by bolts to the bottom plate of the instrument. A pyrgeometer is sensitive to thermal shocks. Do not mount the instrument with the body in direct thermal contact to the mounting plate (so always use the levelling feet also if the mounting is not horizontal), do not mount the instrument on objects that become very hot (black coated metal plates).
instrument mounting with 2 bolts	2 x M5 bolt at 65×10^{-3} m center to center distance on north-south axis, connection from below under the bottom plate of the instrument. Maximum insertion depth 7.5×10^{-3} m.
instrument mounting with one bolt	1 x M6 bolt at the center of the instrument, connection from below under the bottom plate of the instrument. Maximum insertion depth 6×10^{-3} m.
performing a representative measurement	The pyrgeometer measures the solar radiation in the plane of the sensor. This may require installation in a tilted or inverted position. The sensor surface (sensor bottom plate) should be mounted parallel to the plane of interest. In case a pyrgeometer is not mounted horizontally or in case the horizon is obstructed, the representativeness of the location becomes an important element of the measurement. See the chapter on uncertainty evaluation.
leveling	In case of horizontal mounting only use the bubble level and levelling feet. For inspection of the bubble level the sun screen must be removed.
Instrument orientation	by convention with the cable exit pointing to the nearest pole (so the cable exit should point north in the northern hemisphere, south in the southern hemisphere).
Installation height	in case of inverted installation, WMO recommends a distance of 1.5 m between soil surface and sensor (reducing the effect of shadows and in order to obtain good spatial averaging).
optional shading	for ultra-high accuracy measurements the solar offset can be reduced by around 60 % by "shading", which means preventing the direct radiation to reach the instrument. Shading is typically done by using a shading disk on a solar tracker.

4.2 Installation of the sun screen

IR20's sun screen can be installed and removed by using the dedicated thumb screw. See item 2 of the drawing below. The thumb screw can be turned without tools for fixation or loosening of the sun screen, as visualized below. Once the thumb screw has turned the sun screen loose, the screen can be lifted off manually. After removal the user may inspect the bubble level, item 8 of the drawing, and remove the cable / connector, item 9.



Figure 4.2.1 Installation and removal of IR20's sun screen.

4.3 Electrical connection

In order to operate, a pyrogeometer should be connected to a measurement system, typically a so-called data logger. IR20 is a passive sensor that does not need any power. Cables generally act as a source of distortion, by picking up capacitive noise. We recommend keeping the distance between a datalogger or amplifier and the sensor as short as possible. For cable extension, see the appendix on this subject.

Table 4.3.1 The electrical connection of IR20. The heater is not necessarily used. The temperature sensor must be used.

PIN	wire	IR20
2	red	10 kΩ thermistor [+]
3	pink	10 kΩ thermistor [+]
6	blue	10 kΩ thermistor [-]
8	gray	10 kΩ thermistor [-]
1	brown	heater
4	yellow	heater
9	black	ground
7	white	signal [+]
5	green	signal [-]

Note 1: 10 kΩ thermistors are usually connected in a 2-wire configuration.

Note 2: the heater is not necessarily connected. In case it is connected, the polarity of the connection is not important.

Note 3: signal wires are insulated from ground wire and from the sensor body. Insulation resistance is tested during production and larger than $1 \times 10^6 \Omega$.

Note 4: ground is connected to the connector, the sensor body and the shield of the wire.

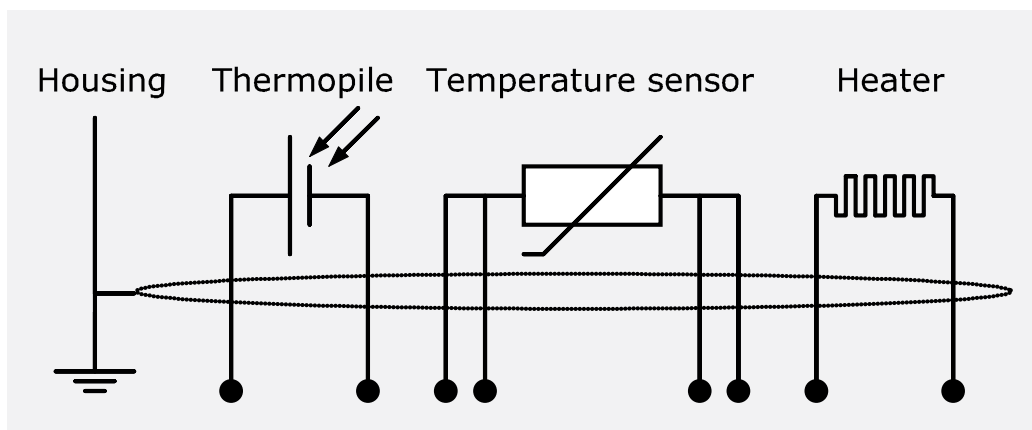

Figure 4.3.1 Electrical diagram of the internal wiring of IR20. The shield is connected to the sensor body.

4.4 Requirements for data acquisition/amplification

The selection and programming of data loggers is the responsibility of the user. Please contact the supplier of the data acquisition and amplification equipment to see if directions for use with the IR20 are available. In case programming for similar instruments is available, this can typically also be used. IR20 can usually be treated in the same way as other thermopile pyrgeometers.

Table 4.4.1 Requirements for data acquisition and amplification equipment for IR20 in the standard configuration .

capability to measure small voltage signals	Preferably: better than 5×10^{-6} V uncertainty Minimum requirement: 20×10^{-6} V uncertainty (valid for the entire expected temperature range of the acquisition / amplification equipment).
capability for the data logger or the software	To store data, and to perform division by the sensitivity to calculate the solar and longwave and irradiance and other . optional measurands.
data acquisition input resistance	$> 1 \times 10^6 \Omega$
open circuit detection (WARNING)	Open-circuit detection should not be used, unless this is done separately from the normal measurement by more than 5 times the sensor response time and with a small current only. Thermopile sensors are sensitive to the current that is used during open circuit detection. The current will generate heat, which is measured and will appear as an offset.
capability to measure temperature	A 10 k Ω thermistor must be read-out. Required accuracy of the readout is ± 0.2 °C, which results in around 1 W/m ² uncertainty of the irradiance measurement.
capability to power the heater (OPTIONAL)	IR20 has a 12 VDC, 1.5 W heater on board, which may optionally be activated to keep the instrument above dew point. Some users prefer to have the heater on full time, others prefer to switch it on during nighttime only.

5

Making a dependable measurement

5.1 The concept of dependability

A measurement with a pyrgeometer is called "dependable" if it is reliable, i.e. measuring within required uncertainty limits, for most of the time and if problems, once they occur, can be solved quickly.

The requirements for a measurement with a pyrgeometer may be expressed by the user as:

- required uncertainty of the measurement (see following paragraphs)
- requirements for maintenance and repairs (possibilities for maintenance and repair including effort to be made and processing time)
- a requirement to the expected instrument lifetime (until it is no longer feasible to repair)

It is important to realize that the uncertainty of the measurement is not only determined by the instrument, but also by the way it is used.

In case of pyrgeometers, the measurement uncertainty as obtained during outdoor measurements is a function of:

- the instrument properties
- the calibration procedure / uncertainty
- the presence of natural sunlight (involving the instrument specification of solar offset)
- the measurement conditions (such as tilting, ventilation, shading, heating, instrument temperature)
- maintenance (mainly fouling and deposition of water)
- the environmental conditions* (such as temperature, position of the sun, presence of clouds, horizon, representativeness of the location)

Therefore statements about the overall measurement uncertainty under outdoor conditions can only be made on an individual basis, taking all these factors into account.

* defined at Hukx as all factors outside the instrument that are relevant to the measurement, such as the cloud cover (presence or absence of direct radiation), sun position, the local horizon (which may be obstructed) or condition of the ground (when inverted). The environmental conditions also involve the question whether or not the measurement at the location of measurement is representative of the quantity that should be measured.

5.2 Reliability of the measurement

A measurement is reliable if it measures within required uncertainty limits for most of the time. We distinguish between two causes of unreliability of the measurement:

- Related to the reliability of the pyrgometer and its design, manufacturing, calibration (hardware reliability).
- Related to the reliability of the measurement uncertainty (measurement reliability), which involves hardware reliability as well as condition of use.

Most of the hardware reliability is the responsibility of the instrument manufacturer. The reliability of the measurement, however, is a joint responsibility of instrument manufacturer and user. As a function of user requirements, taking into account measurement conditions and environmental conditions, the user will select an instrument of a certain class, and define maintenance support procedures.

In many situations, there is a limit to a realistically attainable accuracy level. This is due to conditions that are beyond control once the measurement system is in place. Typical limiting conditions are:

- The measurement conditions, for instance when working at extreme temperatures when the instrument temperature is at the extreme limits of the rated temperature range.
- The environmental conditions, for instance when installed at a sub-optimal measurement location with obstacles in the field of view.
- The environmental conditions, for instance when assessing net radiation, the downfacing pyrgometer measurement may not be representative of irradiance received in that particular area.

The measurement reliability can be improved by maintenance support. Important aspects are:

- Dome fouling by deposition of dust, dew, rain or snow. With pyrgometers, the most important source of unreliability is deposition of water on the dome. Water completely blocks the longwave radiation flux between sensor and sky. In particular, at clear nights this causes very large errors. Water deposition under clear-sky nighttime conditions can largely be prevented by using the instrument heater. Fouling results in undefined measurement uncertainty (sensitivity and directional error are no longer defined). This should be solved by regular inspection and cleaning.
- Sensor instability. Maximum expected sensor aging is specified per instrument as its non-stability in [% change/year]. In case the sensor is not recalibrated, the uncertainty of the sensitivity gradually will increase. This is solved by regular recalibration.
- Moisture condensing under pyrgometer domes resulting in a slow change of sensitivity (within specifications). This is solved by regular replacement of desiccant or by maintenance (drying the entire sensor) in case the sensor allows this. For non-serviceable sensors like Hukx flat window pyrgometers (for example model IR02), this may slowly develop into a defect. For model IR20 extra desiccant (in a set of 5 bags in an air-tight bag) is available.

- One of the larger errors in the daytime measurement of downwelling longwave irradiance is the offset caused by solar radiation; the “solar offset”. Errors due to solar offset, are of the order of + 10 W/m² at 1000 W/m² global horizontal irradiance. For ultra-high accuracy measurements this offset can be reduced by around 60% by “shading”, which means preventing the direct radiation to reach the instrument. Shading is typically done by using a shading disk on a solar tracker.

Another way to improve measurement reliability is to introduce redundant sensors.

- The use of redundant instruments allows remote checks of one instrument using the other as a reference, which leads to a higher measurement reliability.

5.3 Speed of repair and maintenance

Dependability is not only a matter of reliability, but also involves the reaction to problems; if the processing time of service and repairs is short, this contributes to the dependability.

Hukx pyrgeometers are designed to allow easy maintenance and repair.

The main maintenance actions are:

- replacement of desiccant
- replacement of cabling

For optimization of dependability, a user should:

- Estimate the expected lifetime of the instrument.
- Design a schedule of regular maintenance.
- Design a schedule of repair or replacement in case of defects.

When operating multiple instruments in a network, Hukx recommends keeping procedures simple and having a few spare instruments to act as replacements during service, recalibrations and repair.

5.4 Uncertainty evaluation

The uncertainty of a measurement under outdoor or indoor conditions depends on many factors, see paragraph 1 of this chapter. It is not possible to give one figure for pyrgeometer measurement uncertainty. The work on uncertainty evaluation is “in progress”. There are several groups around the world participating in standardization of the method of calculation. The effort aims to work according to the guidelines for uncertainty evaluation (according to the “Guide to Expression of Uncertainty in Measurement” or GUM).

The main ingredients of the uncertainty evaluation for pyrgeometers are:

- Calibration uncertainty, which is in the order of $\pm 6\%$ ($k = 2$) for upfacing instruments measuring downward longwave irradiance.
- Calibration uncertainty, which is larger for other than upfacing instruments; for downfacing instruments a blackbody calibration seems preferable. Blackbody calibration will result in a lower sensitivity (S_0) than WISG traceable calibration.
- Errors due to water deposition at clear nights; these completely block the longwave irradiance exchange between pyrgeometer and may cause the signal $U/(S_0 \cdot (a \cdot T^2 + b \cdot T + c))$ to change from a large negative value (-100 W/m^2) to around 0 W/m^2 . Water deposition at clear nights may largely be avoided by using the on-board heater of IR20.
- Errors due to solar offset, which is of the order of $+10 \text{ W/m}^2$ at 1000 W/m^2 global horizontal irradiance. This offset can be reduced by around 60% by shading of the instrument, typically by using a shading disk on a solar tracker. This error is partially caused by heating of the dome, partially by transmission of solar radiation by the dome/filter combination. This uncertainty is not taken into account in the WISG calibration of the reference instrument. With IR20WS, only measuring at night, this uncertainty does not play a significant role.
- Errors due to the choice of the cut-on wavelength of the pyrgeometer. Depending on the atmospheric water content, the pyrgeometer will block a variable percentage of the downward longwave irradiance. This causes an uncertainty of the sensitivity S_0 . With IR20, this uncertainty is already taken into account in the WISG calibration of the reference instrument. With IR20WS this uncertainty does not play a significant role.
- Errors due to instrument non-stability. This is now estimated at $< \pm 1\%$ change per year. The main factor in instrument non-stability is the aging of the pyrgeometer solar blind filter. For IR20WS this filter is not present. For that reason we expect IR20WS to have a better non-stability.
- Errors due to the temperature measurement T . For this, a $10 \text{ k}\Omega$ thermistor must be read-out. Required accuracy of the readout is $\pm 0.2 \text{ }^\circ\text{C}$, which results in around 1 W/m^2 uncertainty of the irradiance measurement. To this, the uncertainty of the thermistor itself should be added. In measurement of net radiation, in case the upfacing and downfacing instruments are thermally coupled, the temperature measurement (and also its uncertainty) cancel from the equation.

6 Maintenance and trouble shooting

6.1 Recommended maintenance and quality assurance

IR20 can measure reliably at a low level of maintenance in most locations. Usually unreliable measurements will be detected as unreasonably large or small measured values. As a general rule this means that regular visual inspection combined with a critical review of the measured data, preferably checking against other measurements, is the preferred way to obtain a reliable measurement.

Table 6.1.1 Recommended maintenance of IR20. If possible, the data analysis and cleaning (1 and 2) should be done on a daily basis. (continued on next page).

Minimum recommended pyranometer maintenance			
	interval	subject	action
1	1 week	data analysis	Compare measured data to maximum possible/ maximum expected irradiance and to other measurements nearby (redundant instruments). Also, historical seasonal records can be used as a source for expected values. Look for any patterns and events that deviate from what is normal or expected.
2	2 weeks	cleaning	Use a soft cloth to clean the dome of the instrument, persistent stains can be treated with soapy water or alcohol.
3	6 months	inspection	Inspect cable quality, inspect cable glands, inspect mounting position, inspect cable, clean instrument, clean cable, inspect levelling, change instrument tilt in case this is out of specification, inspect mounting connection.
4		desiccant replacement	Desiccant replacement (if applicable). Change in case the humidity indicator shows more than 50 %, then replace desiccant. Coat the rubber of the cartridge with silicone grease or vaseline. Desiccant regeneration: heating in an oven at 70 °C for 1 to 2 hours. Humidity indicator regeneration: heating until blue at 70 °C.

5	2 years	recalibration	Recalibration by side-by-side comparison to a higher standard instrument in the field.
6		lifetime assessment	Judge if the instrument should be reliable for another 2 years, or if it should be replaced.
7	6 years	parts replacement	If applicable/necessary replace the parts that are most exposed to weathering; cable, cable gland, desiccant holder, sun screen. NOTE: use Hukx approved parts only.
8		internal inspection	If applicable: open instrument and inspect/replace O-rings; dry internal cavity around the circuit board.
9		recalibration	Recalibration by side-by-side comparison to a higher standard instrument at the manufacturer or a reference institute. Also, recalibrate the temperature sensor.

6.2 Trouble shooting

Table 6.2.1 Trouble shooting for IR20 (continued on the next page).

<p>The sensor does not give any signal.</p>	<p>Check the electrical resistance of the sensor between the green (-) and white (+) wire. Use a multimeter at the 1000 Ω range. Measure the sensor resistance first with one polarity, than reverse the polarity. Take the average value. The typical resistance of the wiring is 0.1 Ω/m. Typical resistance should be the typical sensor resistance of 100 to 200 Ω plus 1.5 Ω for the total resistance of two wires (back and forth) of each 5 m. Infinite resistance indicates a broken circuit; zero or a low resistance indicates a short circuit.</p> <p>Check if the sensor reacts to heat: put the multimeter at its most sensitive range of DC voltage measurement, typically the 100 x 10⁻³ VDC range or lower. Make sure that the sensor is at 25 °C or lower. Expose the sensor to a heat source at a short distance from the window of more than 50 °C, for instance, a heavy (> 5 kg) painted block of metal, or a painted metal container holding hot water. Face the side of the container to avoid condensation of water on the pyrgeometer window. Stir the water to attain homogeneity. A painted surface will act as a blackbody in the far infrared (FIR), irrespective of the visible color. The signal should read positive and > 1 x 10⁻³ V now. In case of using your hand as a heat source, the signal should be significantly lower. Check the data acquisition by applying a 1 x 10⁻⁶ V source to it in the 1 x 10⁻⁶ V range.</p>
<p>The sensor signal is unrealistically high or low.</p>	<p>Check if the measurement function, including the constant a, b and c has been implemented properly. Please note that each sensor has its own individual calibration factor and constants, as documented in its production certificate.</p> <p>Check if the pyrgeometer has a clean dome.</p> <p>Check the location of the pyrgeometer; are there any obstructions/sources that could explain the measurement result.</p> <p>Check the condition of the wiring at the logger.</p> <p>Check the cable condition looking for cable breaks.</p> <p>Check the range of the data logger; signal is usually negative (this could be out of range) or the amplitude could be out of range.</p> <p>Check the data acquisition by applying a 1 x 10⁻⁶ V source to it in the 1 x 10⁻⁶ V range. Look at the output. Check if the output is as expected.</p> <p>Check the data acquisition by short circuiting the data acquisition input with a 100 to 1000 Ω resistor. Look at the output. Check if it is close to 0 W/m².</p>
<p>The sensor signal shows unexpected variations.</p>	<p>Check the presence of strong sources of electromagnetic radiation (radar, radio etc.)</p> <p>Check the condition of the shielding.</p> <p>Check the condition of the sensor cable.</p> <p>Check if the cable is not moving during the measurement.</p>

The instrument shows internal condensation.	Replace the desiccant and wait a few days to see if the situation improves. In case of condensation of droplets: disassemble the instrument and dry out the parts.
The instrument shows persistent internal condensation.	Arrange to send the sensor back to Hukx for diagnosis.

6.3 Calibration and checks in the field

Recalibration of field pyrgeometers is typically done by comparison in the field to a reference pyrgeometer. There is no standard for this procedure.

Hukx's recommendation for re-calibration: if possible, perform calibration outdoor by comparison to an identical or a higher class reference instrument, under nighttime as well as daytime conditions. Use nighttime data only to determine S_0 . Do not change the constants a, b and c.

Hukx's main recommendations for field intercomparisons are:

1. Perform field calibration during several days; 2 to 3 days and if possible under cloudless conditions.
2. To take a reference of the same brand and type as the field pyrgeometer or a pyrgeometer of a higher class, and
3. To connect both to the same electronics, so that electronics errors (also offsets) are eliminated.
4. To mount all instruments on the same platform, so that they have the same body temperature.
5. To analyze downward irradiance values at nighttime only to determine S_0 .
6. To analyze the daytime data, independently, and look at the residuals between the calibration reference and calibrated instrument as a function of solar irradiance. The solar offset can serve as a quality indicator of the pyrgeometer filter condition.

6.4 Data quality assurance

Quality assurance can be done by:

- Analyzing trends in longwave irradiance signal.
- Plotting the measured irradiance against mathematically generated expected values.
- Comparing irradiance measurements between sites.
- Analysis of daytime signals against solar irradiance.

The main idea is that one should look out for any unrealistic values. There are programs on the market that can semi-automatically perform data screening:

See for more information on such a program: <https://dama-nl.org/dqms-en>

7 Appendices

7.1 Appendix on cable extension/replacement

The sensor cable of IR20 is equipped with a M16 straight connector. In case of cable replacement, it is recommended to purchase a new cable with connector at Hukx. An alternative is to choose for a Do-it-yourself (DIY) approach; please ask for the DIY connector assembly guide. In case of cable extension, the user may choose to purchase a new cable with connector at Hukx or extend the existing cable himself. Please note that Hukx does not provide support for DIY connector- and cable assembly.

IR20 is equipped with one cable. Keep the distance between data logger or amplifier and sensor as short as possible. Cables act as a source of distortion by picking up capacitive noise. In an electrically "quiet" environment, the IR20 cable can be extended without problem to 100 meters. If done properly, the sensor signal, although small, will not significantly degrade because the sensor resistance is very low (so good immunity to external sources) and because there is no current flowing (so no resistive losses). Connector, cable and cable connection specifications are summarized below.

Table 7.1.1 Preferred specifications for IR20 cable replacement and extension (continued on the next page).

general replacement	Please order a new cable with connector at Hukx or choose for a DIY approach. In case of DIY replacement by the user, see connector specifications below and ask for the DIY connector assembly guide.
general cable extension	Please order a new cable with connector at Hukx or solder the new cable conductors and shield to the original sensor cable and make a connection, using adhesive-lined heat shrink tubing, with specifications for outdoor use. Always connect shield.
connectors used	chassis: M16 panel connector, male thread, 10-pole, HUMMEL AG 7.840.200.000 panel connector, front mounting, short version. cable: M16 straight connector, female thread, 10-pole. HUMMEL AG 7.810.300.00M straight connector, female thread, for cable 3 to 6×10^{-3} m, special version
cable	8-wire, shielded, with copper conductors (at Hukx 8-wire shielded cable is used, of which 2 wires are used for signal transmission, 2 for heating and 2 to 4 for the temperature sensor).

conductor resistance	< 0.1 Ω/m
length	Cables should be kept as short as possible, in any case, the total cable length should be less than 100 m.
outer sheath	with specifications for outdoor use (for good stability in outdoor applications)

7.2 Appendix on tools for IR20

Table 7.2.1 Specifications of tools for IR20.

Tooling required for sun screen fixation and removal.	by hand
Tooling required for bottom plate fixation and removal.	hex key 2.5 x 10 ⁻³ m
Tooling required for desiccant holder fixation and removal.	spanner size 20 x 10 ⁻³ m
Tooling required for wire fixation and removal (internal wiring inside IR20 body).	screwdriver blade width 2 x 10 ⁻³ m

7.3 Appendix on spare parts for IR20

- desiccant holder (with glass window and rubber ring)
- desiccant (set of 5 bags in an air tight bag)
- humidity indicator
- leveling feet (set of 2)
- static foot
- sun screen with metal ring and thumb screw
- IR20 cable with connector (specify length in multiples of 5 m)
- O-ring IR20

NOTE: The dome of IR20 and IR20WS cannot be supplied as spare part.

7.4 Appendix on standards for classification and calibration

Unlike pyranometers, pyrgeometers are not subject to a system of classification. At Hukx we distinguish between normal pyrgeometers, like our model IR02, and “research grade” pyrgeometers, like IR20 and IR20WS. The term “research grade” is used to indicate that this instrument has the highest attainable specifications.

7.5 Appendix on calibration hierarchy

Hukx pyrgeometers are traceable to the World Infrared Standard Group (WISG). WISG is composed of a group of pyrgeometers. The calibration hierarchy of Hukx IR20 is from WISG through Hukx internal calibration procedure involving outdoor comparison to a reference pyrgeometer.

The WISG group of instruments is maintained by World Radiation Center (WRC), in Davos Switzerland. An absolute sky-scanning radiometer provides the absolute longwave irradiance reference. Comparisons between the reference and the WISG are performed on a regular basis to maintain the WISG and supervise its long-term stability. It is essential that these intercomparisons take place under various sky conditions, but the predominant condition is a clear sky, which means that the validity of WISG calibration is a clear-sky spectrum. Typical exchange between pyrgeometer and sky is in the -70 to -120 W/m².

At Hukx, in an independent lab experiment, the detector properties are determined as a function of temperature, resulting in temperature coefficients a, b, and c.

WRC works with a measurement equation involving additional constants k_1 , which corrects for thermal resistance of the thermopile sensor, k_2 , which corrects for emissivity that does not equal 1.

$$E = (U / S) (1 + k_1 \cdot \sigma \cdot (T + 273.15)^3) + k_2 \cdot \sigma \cdot (T + 273.15)^4 \quad (\text{Formula 7.5.1})$$

Pyrgeometers are calibrated by WRC in two ways:

- by nighttime comparison to WISG, to determine S.
A typical uncertainty of S is 4.2%.
- by calibration under a blackbody to determine k_1 and k_2 .

There also is a third constant, k_3 , correcting for the difference between dome temperature and thermopile temperature.

The Hukx measurement equation for IR20 is:

$$E = U / (S_0 \cdot (a \cdot T^2 + b \cdot T + c)) + \sigma \cdot (T + 273.15)^4 \quad (\text{Formula 0.1})$$

In other words, Hukx ignores k_1 and assumes that $k_2 = 1$. It is Hukx's opinion that by the design of the instrument, the influence of these parameters is negligible.

Table 7.5.1 Calibration hierarchy for pyranometers.

working standard calibration at PMOD/WRC davos

Calibration of working standard pyrgeometers traceable to WISG.
A typical uncertainty of S_0 is 4.2% ($k = 2$).

correction of (working) standard calibration to standardized reference conditions

Correction from "test conditions of the standard" to "reference conditions" :
No corrections are applied.

Reference conditions are: horizontal mounting, atmospheric longwave irradiance, clear sky nights, 20 °C.

outdoor product calibration

Calibration of products, i.e. pyrgeometers:
Outdoor side-by-side comparison to a reference pyrgeometer.

calibration uncertainty calculation

ISO 98-3 Guide to the Expression of Uncertainty in Measurement, GUM Determination of combined expanded uncertainty of calibration of the product, including uncertainty of the working standard, uncertainty of correction, uncertainty of the method (transfer error). The coverage factor must be determined; at Hukx we work with a coverage factor $k = 2$.

Hukx specifies a calibration uncertainty of $< 6\%$ ($k = 2$).

7.6 Appendix on meteorological radiation quantities

A pyrgeometer measures longwave irradiance. The time integrated total is called radiant exposure.

Table 7.6.1 Meteorological radiation quantities as recommended by WMO (additional symbols by Hukx). POA stands for Plane of Array irradiance. The term originates from ASTM and IEC standards.

symbol	description	calculation	units	alternative expression	
E_{\downarrow}	downward irradiance	$E_{\downarrow} = E_{g\downarrow} + E_{l\downarrow}$	W/m^2		
H_{\downarrow}	downward radiant exposure for a specified time interval	$H_{\downarrow} = H_{g\downarrow} + H_{l\downarrow}$	J/m^2		
E_{\uparrow}	upward irradiance	$E_{\uparrow} = E_{g\uparrow} + E_{l\uparrow}$	W/m^2		
H_{\uparrow}	upward radiant exposure for a specified time interval	$H_{\uparrow} = H_{g\uparrow} + H_{l\uparrow}$	J/m^2	$W \cdot h/m^2$	Change of units
E	direct solar irradiance normal to the apparent solar zenith angle		W/m^2	DNI	Direct Normal Irradiance
E_0	solar constant		W/m^2		
$E_{g\downarrow h}$	global irradiance; hemispherical irradiance on a specified, in this case, horizontal surface*	$E_{g\downarrow} = E \cos \theta_h + E_{d\downarrow}$	W/m^2	GHI	Global Horizontal Irradiance
$E_{g\downarrow t}$	global irradiance; hemispherical irradiance on a specified, in this case, tilted surface*	$E_{g\downarrow} = E \cdot \cos \theta_t + E_{d\downarrow t} + E_{r\uparrow t}$ ***	W/m^2	POA	Plane of Array
$E_{d\downarrow}$	downward diffuse solar radiation		W/m^2	DHI	Diffuse Horizontal Irradiance
$E_{l\uparrow}, E_{l\downarrow}$	upward/downward long-wave irradiance		W/m^2		
$E_{r\uparrow}$	reflected solar irradiance		W/m^2		
E^*	net irradiance	$E^* = E_{\downarrow} - E_{\uparrow}$	W/m^2		
T_{surface}	equivalent blackbody radiative temperature of the surface**		$^{\circ}C$		
T_{sky}	equivalent blackbody radiative temperature of the sky**		$^{\circ}C$		
SD	sunshine duration		H		

θ is the apparent solar zenith angle θ_h relative to horizontal, θ_t relative to a tilted surface
g = global, l = longwave, t = tilted *, h = horizontal*
* distinction horizontal and tilted from Hukx,

** T symbols introduced by Hukx,
*** contributions of $E_{d\downarrow t}$ and $E_{r\uparrow t}$ are $E_{d\downarrow}$ and $E_{r\uparrow}$ both corrected for the tilt angle of the surface

7.7 Appendix on terminology/glossary

Table 7.7.1 Definitions and references of used terms (continued on the next page).

term	definition (reference)
solar energy or solar radiation	Solar energy is the electromagnetic energy emitted by the sun. Solar energy is also called solar radiation and shortwave radiation. The solar radiation incident on the top of the terrestrial atmosphere is called extra-terrestrial solar radiation; 97 % of which is confined to the spectral range of $(290 \text{ to } 3\,000) \times 10^{-9} \text{ m}$. Part of the extra-terrestrial solar radiation penetrates the atmosphere and directly reaches the earth's surface, while part of it is scattered and/or absorbed by the gas molecules, aerosol particles, cloud droplets and cloud crystals in the atmosphere. The former is the direct component, the latter is the diffuse component of the solar radiation. (ref: WMO, Hukx).
hemispherical solar radiation	Solar radiation received by a plane surface from a 180° field of view angle (solid angle of $2\pi \text{ sr}$) (ref: ISO 9060).
global solar radiation	The solar radiation received from a 180° field of view angle on a horizontal surface is referred to as global radiation. Also called GHI. This includes radiation received directly from the solid angle of the sun's disc, as well as diffuse sky radiation that has been scattered in traversing the atmosphere (ref: WMO). Hemispherical solar radiation received by a horizontal plane surface (ref: ISO 9060).
Plane of Array irradiance	Also POA: hemispherical solar irradiance in the plane of a PV array (ref: ASTM E2848 - 13 / IEC 61724).
direct solar radiation	Radiation received from a small solid angle centered on the sun's disc, on a given plane (ref: ISO 9060).
terrestrial or longwave radiation	Radiation not of solar origin, but of terrestrial and atmospheric origin and having longer wavelengths ($3\,000 \text{ to } 100\,000 \times 10^{-9} \text{ m}$). In case of downwelling E_{\downarrow} , also the background radiation from the universe is involved, passing through the "atmospheric window". In case of upwelling E_{\uparrow} , composed of long-wave electromagnetic energy emitted by the earth's surface and by the gases, aerosols and clouds of the atmosphere; it is also partly absorbed within the atmosphere. For a temperature of 300 K, 99.99 % of the power of the terrestrial radiation has a wavelength longer than $3\,000 \times 10^{-9} \text{ m}$ and about 99 per cent longer than $5\,000 \times 10^{-9} \text{ m}$. For lower temperatures, the spectrum shifts to longer wavelengths (ref: WMO).
World Radiometric Reference (WRR)	Measurement standard representing the SI unit of irradiance with an uncertainty of less than $\pm 0.3\%$ (see the WMO Guide to Meteorological Instruments and Methods of Observation, 1983, subclause 9.1.3). The reference was adopted by the World Meteorological Organization (WMO) and has been in effect since 1 July 1980 (ref: ISO 9060).

albedo	Ratio of reflected and incoming solar radiation. Dimensionless number that varies between 0 and 1. Typical albedo values are: < 0.1 for water, from 0.1 for wet soils to 0.5 for dry sand, from 0.1 to 0.4 for vegetation, up to 0.9 for fresh snow.
angle of incidence	Angle of radiation relative to the sensor measured from normal incidence (varies from 0 to 90 °).
zenith angle	Angle of incidence of radiation, relative to zenith. Equals angle of incidence for horizontally mounted instruments.
azimuth angle	Angle of incidence of radiation, projected in the plane of the sensor surface. Varies from 0 to 360 °. 0 ° is by definition the cable exit direction, also called north, east is + 90°.
sunshine duration	Sunshine duration during a given period is defined as the sum of that sub-period for which the direct solar irradiance exceeds 120 W/m ² (ref: WMO).
WISG	World Infra Red Standard Group. Group of pyrgeometers, maintained by PMOD Davos Switzerland that forms the reference for calibration of pyrgeometers. WISG is traceable to international standards through an absolute sky scanning radiometer. WISG has been formally recognized by the World Meteorological Organization WMO as "interim WMO Pyrgeometer Infrared Reference".
sky temperature	Equivalent blackbody radiative temperature of the sky; i.e. the temperature calculated from pyrgeometer data measuring downwelling longwave radiation, assuming the sky behaves as a blackbody with an emission coefficient of 1.
surface temperature	Equivalent blackbody radiative temperature of the surface; i.e. the temperature calculated from pyrgeometer data measuring upwelling longwave radiation, assuming the ground behaves as a blackbody with an emission coefficient of 1.

7.8 EU declaration of conformity

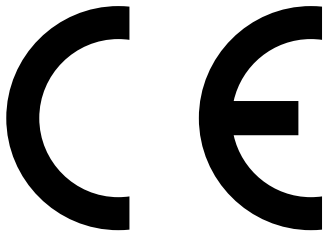

We, Hukseflux Thermal Sensors B.V.,
Delftechpark 31, 2628 XI, Delft,
The Netherlands

hereby declare under our sole responsibility that:

Product models	IR20 and IR20WS
Product type	Pyrgeometer
Brand name	Hukx

conform with the following directives

2011/65/EU, EU 2015/863	The Restriction of Hazardous Substances Directive
2014/30/EU	The Electromagnetic Compatibility Directive

This conformity is declared using the relevant sections and requirements of the following standards

Hazardous substances	RoHS 2 and EU 215/863 amendment known as RoHS 3, EN IEC 63000:2018
EMC Emission	EN IEC 61326-1:2013 (test report 08C01340RPT01)
EMC Immunity	EN IEC 61326-1:2013 (test report 08C01340RPT01)

A handwritten signature in black ink, appearing to read 'Kees Van Den Bos', with a long, sweeping underline.

Kees VAN DEN BOS
Director
Delft, 20 April, 2016

About Hukx

Hukx is the leading innovator in solar radiation and heat flux sensor technology. We are proud to set the standard in high-accuracy measurement, and to be working at the heart of the energy transition.

Customers worldwide rely on our bestselling pyranometers and heat flux sensors. From sensor design and selection to supply and recalibration, we support you across the entire lifecycle.

Hukx is headquartered in the Netherlands, with locally owned representative sales offices in the USA, Brazil, India, China, Southeast Asia, and Japan.

Let us help you select the best sensor for your application. Get in touch with our experts today via: info@hukx.com

© Hukx

v2511

We reserve the right to change specifications without prior notice.

www.hukx.com

HUKX