

HUKX

Sensor
Technology

Brochure
Research-grade
pyrgeometers

**IR20
IR20WS**

IR20 & IR20WS

Research-grade pyrgeometers

IR20 is a research-grade pyrgeometer suitable for high-accuracy longwave irradiance measurement in meteorological and climatological applications. Thanks to Hukx's technological innovation, IR20 is offered at a significantly lower price level than competing models of the same performance level. IR20 can measure during both day and night. In the absence of solar radiation, model IR20WS measures with even higher accuracy due to its wider spectral range.

IR20 measures the longwave or far-infrared radiation (FIR) received by a plane surface, in W/m^2 , from a 180° field of view angle. In meteorological terms, pyrgeometers measure "downward and upward longwave irradiance" (WMO definition). Longwave radiation refers to the portion of atmospheric radiation that is not emitted by the sun. While the spectral range of longwave radiation is not standardized, a practical cut-on is in the range

of 4 to 5×10^{-6} m. IR20 features a dome with a solar-blind filter with a cut-on at 4.5×10^{-6} m, making it suitable for both day and night observations.

Model IR20WS has a wide spectral range with a cut-on at 1.0×10^{-6} m. It offers superior accuracy during nighttime, when solar radiation is absent.

Figure 1 IR20 research-grade pyrgeometer.



IR20 & IR20WS design & benefits

- breakthrough pricing: High performance at a significantly lower price level, as a result of Hukx's technological innovation.
- temperature dependence correction via measurement function: Far more accurate than internal temperature compensation, especially at extreme temperatures. Every pyrheliometer is supplied with temperature coefficients to enter into the equation.
- high sensitivity: With sufficient input signal, a typical data logger no longer significantly contributes to measurement uncertainty.
- low thermal resistance of the sensor: Unlike competing designs, IR20 requires no major correction for temperature differences between the pyrheliometer body and sensor surface.
- fast response time (3 s): Ideal for measurements on moving platforms, such as aircraft and buoys.
- on-board heater: Prevents condensation on the pyrheliometer dome, which can cause very large measurement errors.
- spectral data: Instrument cut-on wavelength (5%) and two 50% transmission points are displayed on the product certificate for individual sensors.

Options

- longer cable, in multiples of 5 m

Suggested use

- climatological networks
- extreme climates (polar/tropical)
- moving platforms (aircraft, buoys)
- uncertainty assessment (IR20 + IR20WS)
- calibration reference (IR20WS)



Figure 3 IR20 pyrheliometer being prepared for application.

See also

- [the making of IR20](#) documented
- Pyrheliometers are often used in combination with pyranometers for solar radiation (shortwave) measurement. View our complete [product range of solar sensors](#).
- [IR02 pyrheliometer](#) for lower accuracy measurements
- [NR01 4-component netradiometer](#) employing 2 pyrheliometers similar to IR02

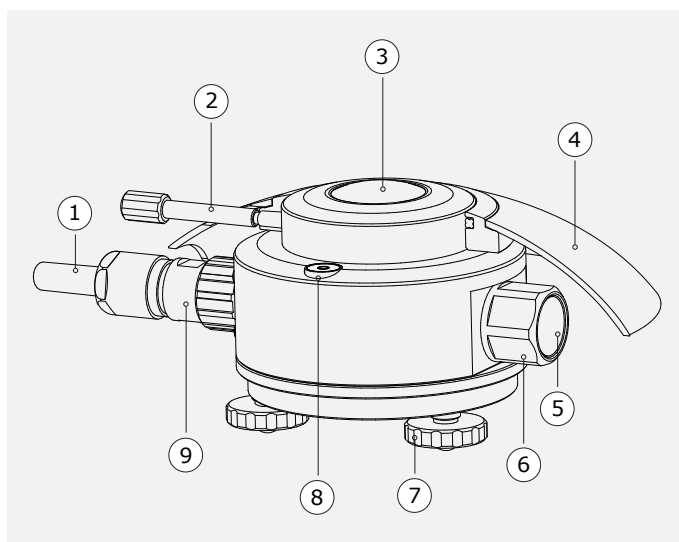

Figure 2 Overview of IR20:

1. cable
2. fixation of sun screen
3. dome with solar-blind filter
4. sun screen
5. humidity indicator
6. desiccant holder
7. leveling feet
8. bubble level
9. connector

IR20 & IR20WS specifications

General specifications

measurand	longwave radiation
optional measurand	sky temperature
optional measurand	surface temperature
spectral range IR20	4.5* to 42 x 10 ⁻⁶ m
spectral range IR20WS	1.0 to 50 x 10 ⁻⁶ m
IR20WS restrictions for use	only in the absence of solar radiation
field of view angle	180 °
response time (95 %)	3 s
sensitivity (nominal)	17 x 10 ⁻⁶ V/(W/m ²)

rated operating temperature range	-40 to +80 °C
temperature dependence	< ± 0.4 % (-30 to +50 °C)
calibration traceability	to WISG
temperature sensor	10kΩ thermistor
heater	12 VDC, 1.5 W
standard cable length	5 m

* nominal, see product certificate for individual value

About Hukx

Hukx is the leading innovator in solar radiation and heat flux sensor technology. We are proud to set the standard in high-accuracy measurement, and to be working at the heart of the energy transition.

Customers worldwide rely on our bestselling pyranometers and heat flux sensors. From sensor design and selection to supply and recalibration, we support you across the entire lifecycle.

Hukx is headquartered in the Netherlands, with locally owned representative sales offices in the USA, Brazil, India, China, Southeast Asia, and Japan.

Let us help you select the best sensor for your application. Get in touch with our experts today via: info@hukx.com

© Hukx

Version 2505

We reserve the right to change specifications without prior notice.

www.hukx.com

HUKX