

**HUKX**

Sensor  
Technology

User manual  
Analog Class A & B  
pyrheliometers

**DR20-A1**  
**DR15-A1**

# Warning statements



Putting more than 12 Volt across the signal wiring can lead to permanent damage to the sensor.



Do not use "open circuit detection" when measuring the sensor output.



For proper instrument grounding:  
Use DR20-A1 and DR15-A1 with its original factory-made cable.



Disconnect power while performing service or maintenance.

# Contents

<b>Introduction</b>	<b>6</b>
<b>1 Ordering and checking at delivery</b>	<b>10</b>
1.1 Ordering DR20-A1 and/or DR15-A1	10
1.2 Included items	11
1.3 Quick instrument check	11
<b>2 Instrument principle and theory</b>	<b>12</b>
2.1 Why you need a “spectrally flat” pyrheliometer	14
2.2 Operating modes: heating	15
<b>3 Specifications of DR20-A1 / DR15-A1</b>	<b>17</b>
3.1 Specifications	17
3.2 Dimensions of DR20-A1 / DR15-A1	23
<b>4 Standards and recommended practices for use</b>	<b>24</b>
4.1 Classification standards	24
4.2 General rules for solar radiation measurement	24
4.3 General use for sunshine duration measurement	25
4.4 Specific use in meteorology and climatology	25
<b>5 Installation of pyrheliometers</b>	<b>26</b>
5.1 Site selection and installation	26
5.2 Mounting	26
5.3 Electrical connection	28
5.4 Grounding and use of the shield	29
<b>6 Making a dependable measurement</b>	<b>30</b>
6.1 The concept of dependability	30
6.2 Reliability of the measurement	31
6.3 Speed of repair and maintenance	32
6.4 Uncertainty evaluation	32
6.5 Definition of the measurand	32
6.6 Contributions from circumsolar radiation	32
6.7 Instrument classification, and approaches to uncertainty evaluation	34
6.8 Evaluation of measurement uncertainty under outdoor conditions	34
6.9 Calibration uncertainty	36
<b>7 Maintenance and trouble shooting</b>	<b>37</b>
7.1 Recommended maintenance and quality assurance	37
7.2 Trouble shooting	38
7.3 Calibration and checks in the field	40
7.4 Data quality assurance	40
<b>8 Appendices</b>	<b>41</b>
8.1 Appendix on cable extension/replacement	41
8.2 Appendix on tools for DR20-A1 / DR15-A1	42
8.3 Appendix on spare parts for DR20-A1 / DR15-A1	42
8.4 Appendix on standards for classification and calibration	43
8.5 Appendix on calibration hierarchy	44
8.6 Appendix on requirements for solar tracking	45
8.7 Appendix on meteorological radiation quantities	46
8.8 Appendix on ISO and WMO classification tables	47

8.9 Appendix on ISO 9060:1990 classification no longer valid	49
8.10 Appendix on the definition of pyrhelimeter specifications	50
8.11 Appendix on terminology/glossary	52
8.12 Appendix on converting resistance to temperature	55
8.13 Appendix on literature references	56
8.14 EU declaration of conformity	57

# List of symbols

<b>quantities</b>	<b>symbol</b>	<b>unit</b>
voltage output	U	V
solar irradiance	E	W/m <sup>2</sup>
sensitivity	S	V/(W/m <sup>2</sup> )

(see also Appendix 8.7 on meteorological quantities)

**subscripts**  
not applicable

# Introduction

DR20-A1 and DR15-A1 are high-accuracy, direct (normal incidence) solar radiation sensors, also known as pyrhelimeters. DR20-A1 complies with Class A and DR15-A1 with Class B specifications of the ISO 9060:2018 standard. These instruments are designed for tracker-mounted operation and offer analog millivolt outputs. Both pyrhelimeters have superior window heating that leads to high data availability by mitigating dew and frost.

Hukx's DR15-A1 pyrhelimeter is an ISO 9060 spectrally flat Class B instrument and replaces the older DR01, DR02, and DR03 models. DR20-A1 is a new Class A instrument with an improved temperature response compared to DR15-A1. Both instruments offer the highest accuracy and data availability, featuring window heating at low offsets. At the same heating power, the heating has been improved by a factor of 4, at just a quarter of the offset!

DR20-A1 and DR15-A1 are engineered for high-accuracy measurement of direct solar radiation—also known as Direct Normal Irradiance (DNI)—received by a plane surface from a 5° full field of view angle. DNI is expressed in  $W/m^2$ . For optimal results, the instrument must be mounted on a two-axis tracker to stay pointed at the sun.

## Heated for high data availability

High data availability is attained by heating the front window, which suppresses dew and frost deposition at a very low power consumption. DR20-A1 and DR15-A1 only require 1 W to keep their window free from dew and frost.

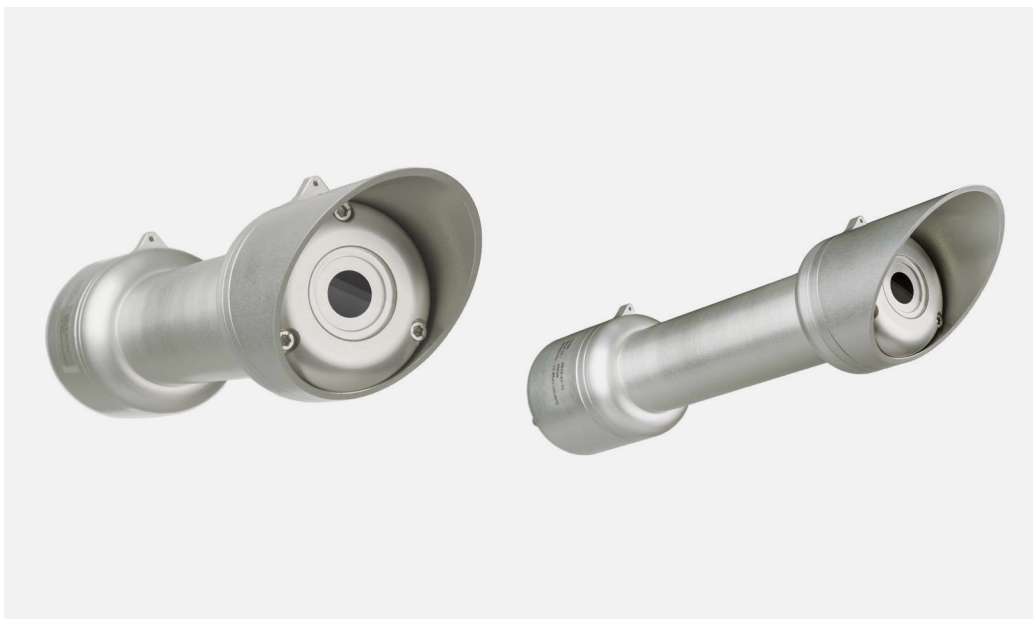

Figure 01 DR20-A1 Class A and DR15-A1 Class B pyrhelimeters: the external housing of these instruments is identical.

A pyr heliometer is used in tracker-mounted operation. Using DR20 / DR15 pyr heliometer is easy. It can be connected directly to commonly used data logging systems. The irradiance, E, in  $W/m^2$  is calculated by dividing the DR20 / DR15 output, a small voltage U, by the sensitivity S. The sensitivity is provided with DR20 / DR15 on its calibration certificate.

The central equation governing DR20 and DR15 is:

$$E = U/S \quad \text{(Formula 0.1)}$$

The temperature dependence of every individual DR20 pyr heliometer is tested and supplied as a second degree polynomial. This information can be used for further reduction of temperature dependence during post-processing. In case the sensitivity is corrected for the instrument body temperature, the optional measurement equation becomes:

$$E = U/(S_0 \cdot (a \cdot T^2 + b \cdot T + c)) \quad \text{(Formula 0.2)}$$

The temperature coefficients a, b, and c can be found on the calibration certificate of each DR20 instrument.

Both DR20 and DR15 are equipped with an internal temperature sensor. This can be either a Pt100 (T1 version) or a 10 k $\Omega$  thermistor (T2 version), as ordered. To calculate temperature in degrees Celsius from resistance in Ohms, Formula 8.12.1 or 8.12.2 can be used. See the dedicated chapter in the appendix of this manual for these equations.

### Liabilities covered: test certificates

As required by ISO 9060 for Class A classification, each DR20-A1 is supplied with test results for the individual instrument:

- sensitivity
- response time
- temperature response

DR15-A1 certificates include sensitivity and response time only.



Figure 0.2 Application of DR20-A1 and DR15-A1 pyr heliometers, here with SR15-A1 pyranometers, in a typical solar radiation monitoring station.

## DR20-A1 and DR15-A1 use

A pyr heliometer is designed for tracker-mounted operation. DR20-A1 and DR15-A1 connect directly to commonly used data logging systems and offer analog outputs in the millivolt range.

## DR20-A1 and DR15-A1 design

The pyr heliometer features a precision-ground and polished quartz window, a compact collimated tube, and a thermopile sensor with a black-coated surface.



Figure 0.3 DR20 / DR15 pyr heliometer side view.

## Suggested use

- solar energy surveys
- solar resource assessments
- meteorological networks
- sites with dew and frost problems

A pyr heliometer can also be used to measure sunshine duration. Sunshine duration during a given period is defined as the sum of that sub-period for which the direct solar irradiance exceeds  $120 \text{ W/m}^2$ .

Applicable instrument classification standards are ISO 9060 and WMO-No. 8. Calibration is traceable to WRR (World Radiometric Reference).

The instrument should be used in accordance with the recommended practices of ISO, WMO, and ASTM.

## Uncertainty evaluation

The uncertainty of a measurement under outdoor conditions depends on many factors. Guidelines for uncertainty evaluation (according to the "Guide to Expression of Uncertainty in Measurement" or GUM) can be found in our manuals. We provide spreadsheets to assist you in evaluating the uncertainty of your measurements

## DR20-A1 and DR15-A1 user benefits

Using DR20-A1 / DR15-A1 pyrheliometers offers significant benefits over competing models. The pyrheliometers offer the highest accuracy and data availability, featuring heating at low offsets. The advantages of having a heater are demonstrated in Chapter 2.2 on heating.

DR20 / DR15 is available with 5 m cable. No other lengths are offered. See the Appendix for cable specifications.

Various tracking solutions can be offered by Hukx. Please contact us for more information on solar trackers.

## See also

- [DR30-D1 digital pyrheliometer](#) with heating, internal tilt sensor, and humidity
- [View our complete product range of sensors.](#)

# 1 Ordering and checking at delivery

## 1.1 Ordering DR20-A1 and/or DR15-A1

DR20 / DR15 pyrheliometers are available in several versions, each with 5 meters cable. No other lengths are offered.

Table 1.1.1 Ordering codes for DR20 / DR15.

Versions of DR20 / DR15 (part numbers)	
DR20-A1-T1	analog spectrally flat Class A pyrheliometer, with heating and Pt100 temperature sensor
DR20-A1-T2	analog spectrally flat Class A pyrheliometer, with heating and 10 kOhm thermistor
DR15-A1-T1	analog spectrally flat Class B pyrheliometer, with heating and Pt100 temperature sensor
DR15-A1-T2	analog spectrally flat Class B pyrheliometer, with heating and 10 kOhm thermistor
<b>cable for DR20 / DR15, with female m12-a connector at sensor end, pigtailed of 0.15 m, and conductors with ferrules</b>	
'-05' after DR20 / DR15 part number	cable length: 5 m



Figure 1.1.1 Front and back view of the DR20 / DR15 pyrheliometer.

## 1.2 Included items

Arriving at the customer, the delivery should include:

- pyrheliometer DR20-A1
- 5 meter cable, if ordered
- product certificate matching the instrument serial number, including:
  - calibration certificate, including sensitivity and response time
  - temperature response test report
- any other options as ordered

or

- pyrheliometer DR15-A1
- 5 meter cable, if ordered
- product certificate matching the instrument serial number, including:
  - calibration certificate, including sensitivity and response time
- any other options as ordered

Please store the certificates in a safe place.

## 1.3 Quick instrument check

A quick test of the instrument can be done by using a simple handheld multimeter and a lamp.

1. Check the electrical resistance of the sensor between the green (-) and white (+) wire. Use a multimeter at the 1000  $\Omega$  range. Measure the sensor resistance first with one polarity, than reverse the polarity. Take the average value. The typical resistance of the cable is 0.1 $\Omega$ /m. Typical resistance should be the typical sensor resistance of 50 to 150  $\Omega$  plus 1.5  $\Omega$  for the total resistance of two wires (back and forth). Infinite resistance indicates a broken circuit; zero or a low resistance indicates a short circuit.
2. Check if the sensor reacts to light: put the multimeter at its most sensitive range of DC voltage measurement, typically the 100 x 10<sup>-3</sup> VDC range or lower. Expose the sensor to a strong light source, for instance a 100 W light bulb at the front window. The signal should read > 2 x 10<sup>-3</sup> V now. Darken the sensor either by putting something over it or switching off the light. The instrument voltage output should go down and within one minute approach 0 V.
3. Inspect the instrument for any damage. Check if the sight is straight and aligned.
4. Optional: inspect the electrical resistance range of the internal temperature sensors (for Pt100 in the 100  $\Omega$  range, for 10 k $\Omega$  thermistors in the 10 000  $\Omega$  range, in case of 3 wire or 4 wire connections of the Pt100 in the < 10  $\Omega$  range between connections at one end).

# 2 Instrument principle and theory

DR20 / DR15's scientific name is pyrhelimeter. It measures the solar radiation received by a plane surface from a  $5^\circ$  full field of view angle. In addition to the full field of view angle, (the angle from the center of the sensor to the edge of the aperture window) WMO recommends in WMO manual 7.2 a slope angle (the angle from the side of the sensor to the edge of the window aperture) of  $1^\circ$ . The opening angle and slope angle, together with the sensor surface, define the so-called acceptance function (see appendix on terminology).

A pyrhelimeter should measure 'direct' solar radiation, also called direct normal irradiance or DNI. DNI is defined as the solar radiant flux collected by a plane unit surface normal to the axis pointing towards the center of the sun, within an optical angular aperture. This aperture is characterized by the acceptance function (ref: Blanc et al. (2014), see appendix on terminology and appendix on literature references). DNI is composed of the solar irradiance within the extent of the solar disk (half-angle  $0.266^\circ \pm 1.7\%$ ) plus some circumsolar radiation.

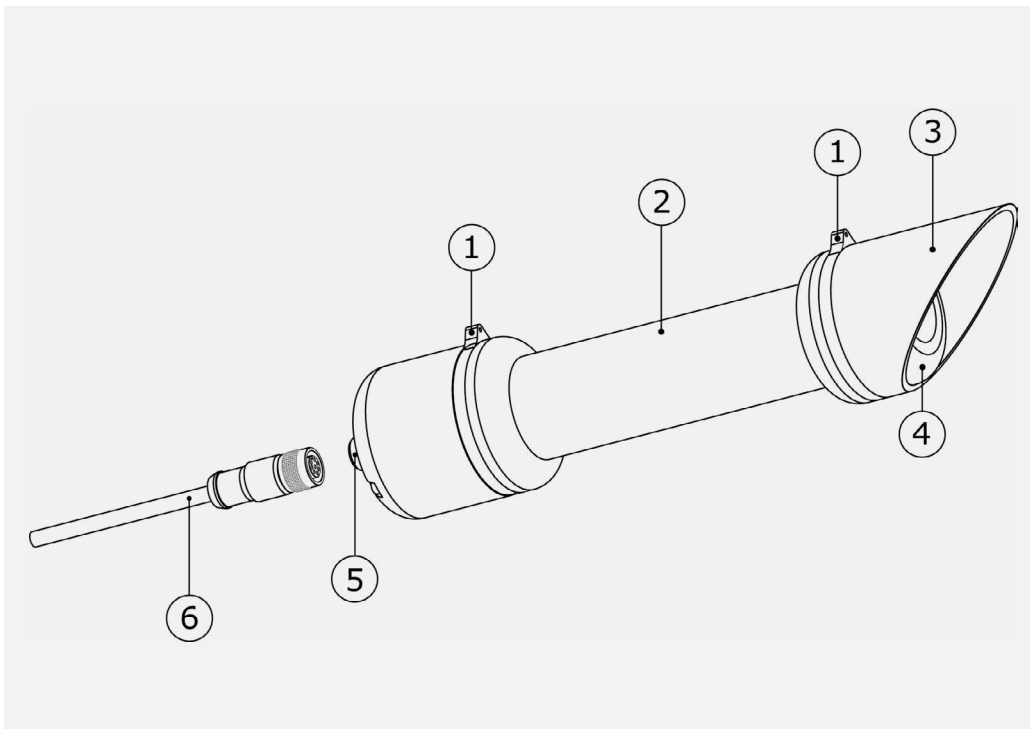

Figure 2.1 Overview of the DR20 / DR15 pyrhelimeter. Versions DR20-A1 and DR15-A1 have an identical external housing.

1. sights
2. aperture tube
3. protection cap
4. window assembly with heater
5. connector
6. cable (length 5 meters)

Summarizing, DR20-A1 and DR15-A1 are radiometers designed to measure DNI (i.e. including some circumsolar irradiance). The instruments comply with the WMO recommended parameters for the view-limiting geometry: a full opening angle of  $5^\circ$ , and a slope angle of  $1^\circ$ , and therefore a limit angle of  $4^\circ$ .

The solar radiation spectrum extends roughly from 285 to  $3000 \times 10^{-9}$  m. By definition, a pyrheliometer should cover that spectral range with a spectral selectivity that is as "flat" as possible.

For a correct measurement, DR20 / DR15 should be pointed at the sun. It is usually mounted on a solar tracker. For tracking requirements, see the appendix on solar tracking.

In order to attain the proper directional and spectral characteristics, DR20 / DR15 pyrheliometer's main components are:

- A thermal sensor with black coating. It has a flat spectrum covering the 200 to  $50000 \times 10^{-9}$  m range. The coating absorbs all solar radiation and, at the moment of absorption, converts it to heat. The heat flows through the sensor to the instrument body. The thermopile sensor generates a voltage output signal that is proportional to the solar irradiance.
- A quartz glass window. This window limits the spectral range from 200 to  $4000 \times 10^{-9}$  m (cutting off the part above  $4000 \times 10^{-9}$  m).
- An aperture tube. The most important components of this tube are two apertures, one at the detector and the other at the front window. These determine the opening and slope angle.
- A heater incorporated in the window assembly. This reduces measurement errors caused by (early-morning) dew deposition. The heater is not necessarily switched on; the recommended operation is to always run the heater.

Pyrheliometers can be manufactured to different specifications and with different levels of verification and characterization during production. The ISO 9060:2018 standard, "*Solar energy – specification and classification of instruments for measuring hemispherical solar and direct solar radiation*", distinguishes between 4 classes: Class AA (highest accuracy), Class A (second highest accuracy), Class B (third highest accuracy) and Class C (fourth highest accuracy).

Due to the required spectral properties, a Class AA pyrheliometer can only be made with a cavity-type sensor. For this reason, commercially available thermopile pyrheliometers with a flat detector and a window can only be Class A.

From Class B to Class A, the achievable accuracy improves by a factor 2.

## 2.1 Why you need a "spectrally flat" pyrheliometer

The new ISO 9060, 2018 version defines classes AA, A, B and C. The standard also adds a new subclass, called "spectrally flat". The term "spectrally flat" may be added to the name of the class (A, B, C) if the instrument has a spectral selectivity of less than 3 % (guard bands 2 %) in the  $(350 \text{ to } 1500) \times 10^{-9} \text{ m}$  range.

The vast majority of users need to use instruments meeting the requirements of this spectrally flat subclass. Why? Only spectrally flat instruments measure with high accuracy, also when a cloud obscures the sun. Ordinary instruments, classified solely as Class A, B or C and not spectrally flat, only measure accurately under clear sunny skies. Compliance with the spectrally flat subclass also means the instrument complies with the WMO guide and keeps continuity with the 1990 version of ISO 9060.

The spectral error of ISO 9060:2018 of a normal (spectrally variable, not flat) pyrheliometer of Class A, B or C is defined as "Clear sky direct normal irradiance spectral error". This error is valid under a clear sky on a sunny day. This is not the common spectrum in normal applications in solar renewable energy, and it is also not the common spectrum in meteorological applications. Even for the most common situations, for example, when a cloud obscures the direct sun or under a cloudy sky, the measurement error with an ordinary Class A, B or C pyrheliometer is undefined. This is why almost all users need a "spectrally flat" pyrheliometer.

Summarizing, specifying "spectrally flat" is essential because this ensures:

- You can measure accurately not only with clear-blue sky, but also when a cloud obscures the sun.
- You comply with WMO; spectrally flat Class A and B instruments comply with the WMO spectral requirements of good quality pyrheliometers. Ordinary instruments do not comply with WMO requirements.
- You can use the normal standardized ISO and WMO calibration procedures, and can benefit from relatively low-cost indoor calibrations. For ordinary Class A, B and C instruments this is not possible.
- You comply with the old ISO 9060 version of 1990, attaining continuity of performance and specifications.
- You can perform uncertainty evaluations with negligible (zero) spectral errors under all conditions, because these are calibrated out.

## 2.2 Operating modes: heating

A feature of both DR20 and DR15 is its built-in heater in the front window assembly. This is effective against dew and frost deposition.

In standard operating mode, the heater is [ON], powered by a 12 VDC source. When no power is available, the heater is [OFF].

As the heater is a resistive element with a nominal resistance of 144  $\Omega$ , the user can change the heating power by adjusting the supply voltage. We define a high power mode with a heater voltage of 24 VDC. This is only necessary in extreme conditions, for example to counter severe frost.

Table 2.2.1 gives an overview of these settings and our recommendations for use.

Table 2.1.1 Possible user scenarios for the heater.

operating module	heater status	power in use (nominal)	comment
standard	[ON]	12 VDC, 1 W	recommended settings
no power	[OFF]	none	
high power	[ON]	24 VDC, 4 W	only necessary in extreme conditions

Heating does not affect the classification specifications and the measurement accuracy.

DR20 / DR15 pyrheliometers offer the highest accuracy and highest data availability, featuring heating at low offsets and low power consumption. The advantages of having a heater are demonstrated in the following graphs:

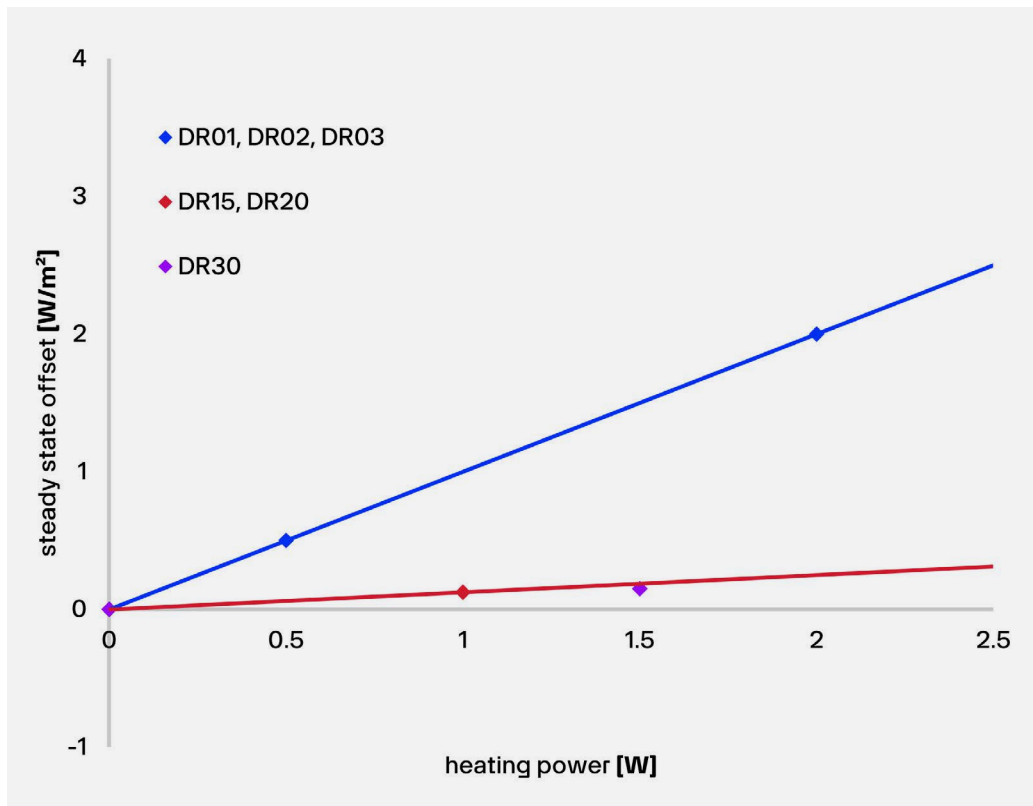

Figure 2.2.1 The offset of the latest models DR20, DR15 (and also the digital DR30) when heating, is much improved relative to the older DR01, DR02 and DR03 models. DR20 and DR15 have a 12 VDC, 1 W heater which produces a negligible offset. The older models had offsets of the order of 1 W/m<sup>2</sup> at the same heating level. In addition, the temperature of the front window of DR20 and DR15 is 4 times higher than that of the older models, at the same heating power.

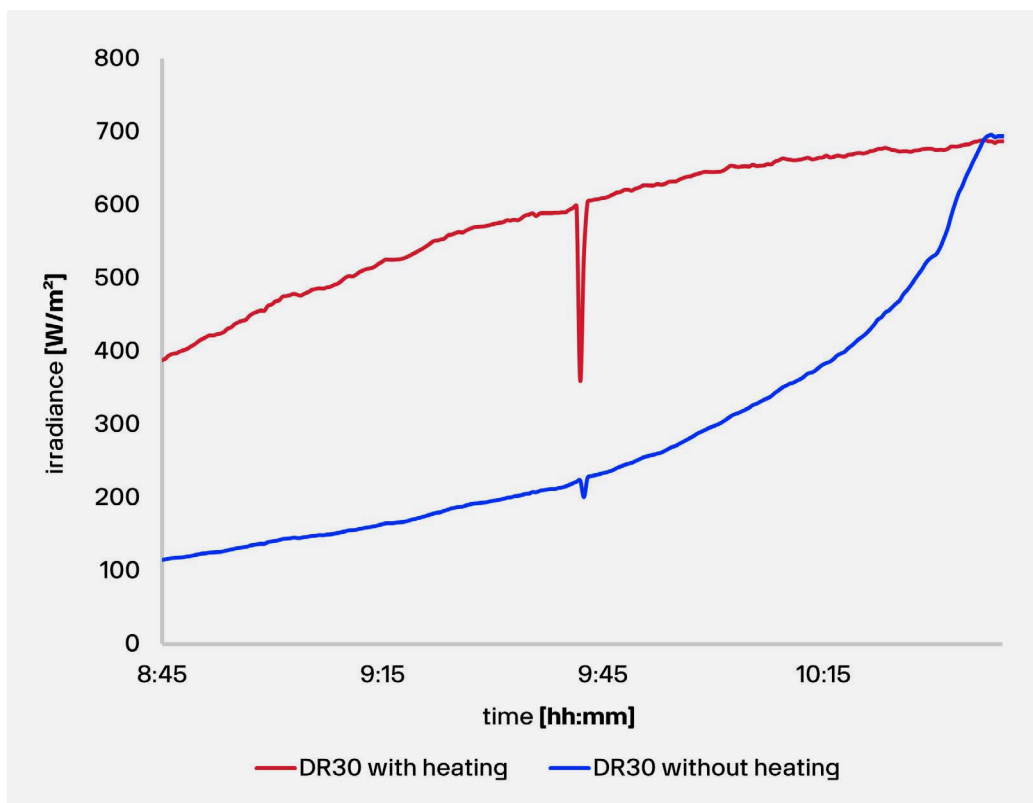

Figure 2.2.2 Comparison of the measured data with and without heating on a typical winter morning, using model DR30 which has the same heating as DR20 and DR15. The unheated DR30 has dew on its front window and strongly underestimates the incoming irradiance. At around 10:30 the dew evaporates. Real measured data from Delft, the Netherlands.

# 3 Specifications of DR20-A1 / DR15-A1

## 3.1 Specifications

DR20 and DR15 pyrhemometers measure the solar radiation received by a plane surface from a from a 5 ° full field of view angle and a 1 ° slope angle, i.e. the acceptance function recommended by WMO. This quantity, expressed in W/m<sup>2</sup>, is called 'direct' solar radiation or direct normal irradiance (DNI). DNI can be used to calculate sunshine duration. Working completely passive, using a thermopile sensor, DR20 / DR15 generates a small output voltage proportional to the DNI. It can only be used in combination with a suitable measurement system and a solar tracker to keep it continuously aimed at the sun. The window assembly contains a heater to prevent dew deposition. The instrument is classified according to ISO 9060 and should be used in accordance with the recommended practices of ISO, WMO and ASTM.

Table 3.1.1 Specifications of DR20 / DR15 (continued on next pages).

<b>DR20-A1 / DR15-A1 measurement specifications: list of classification criteria of iso 9060*</b>	
ISO classification (ISO 9060:2018)	DR20-A1: spectrally flat Class A pyrhemometer DR15-A1: spectrally flat Class B pyrhemometer
ISO classification (ISO 9060: 1990)	DR20-A1: first class pyrhemometer DR15-A1: first class pyrhemometer
WMO performance level (WMO-No. 8, seventh edition 2008)	DR20-A1: good quality pyrhemometer DR15-A1: good quality pyrhemometer
response time (95 %)	4 s (nominal)
zero offset a (response to 5 K/h change in ambient temperature)	< ± 1 W/m <sup>2</sup>
complete zero offset including a)	< ± 1 W/m <sup>2</sup>
non-stability	< ± 0.5 % change per year
non-linearity	< ± 0.2 % (100 to 1000 W/m <sup>2</sup> )
clear-sky direct normal irradiance spectral error	< ± 0.2 %

temperature response	DR20-A1: < ± 0.5 % (-10 to +40 °C) DR20-A1: < ± 0.4 % (-30 to +50 °C) with correction in data processing DR15-A1: < ± 1.0 % (-10 to +40 °C)
temperature response test of individual instrument	DR20-A1: included DR15-A1: not included
additional signal processing errors	0 W/m <sup>2</sup>
tilt response	< ± 0.2 % (0 to 90 ° at 1000 W/m <sup>2</sup> )
full field of view angle	5 °
slope angle	1 °
limit angle	4 ° (follows from full field of view angle and slope angle)

\* For the exact definition of pyrheliometer ISO 9060 specifications, see the appendix.

## Additional specifications

<b>measurand</b>	direct solar radiation with the acceptance function recommended by WMO
measurand in SI radiometry units	irradiance in $W/m^2$
optional measurand	sunshine duration
measurement range	0 to 4000 $W/m^2$
spectral range (50 % transmission points)	200 to 4000 $\times 10^{-9} m$
sensitivity range	10 to 30 $\times 10^{-6} V/(W/m^2)$
sensitivity (nominal)	20 $\times 10^{-6} V/(W/m^2)$
rated operating temperature range	-40 to +80 °C
rated operating relative humidity range	0 to 100 %
sensor resistance range	50 to 150 $\Omega$
required sensor power	zero (passive sensor) heater requires power (12 VDC, 1 W) or (24 VDC, 4 W)
expected voltage output	application under natural solar radiation: -0.1 to +40 $\times 10^{-3} V$
measurement function/required programming	$E = U/S$
optional measurement function/required programming for correction of sensitivity as a function of instrument body temperature	DR20-A1: $E = U/(S_0 \cdot (a \cdot T^2 + b \cdot T + c))$
measurement function/required programming for sunshine duration	if $E > 120 W/m^2$ then $SD = 1$ , else $SD = 0$
required readout	1 differential voltage channel or 1 single-ended voltage channel, input resistance $> 10^6 \Omega$
optional readout	1 resistance measurement channel for the temperature sensor
total sensor length including cap	277 $\times 10^{-3} m$

cable length	5 m
cable diameter	$4.8 \times 10^{-3}$ m
chassis connector	M12-A straight male connector, male thread, 8-pole
chassis connector type	M12-A
cable connector	M12-A straight female connector, female thread, 8-pole
cable connector type	M12-A
connector protection class	IP67 (connected)
cable replacement	Replacement cables with connector can be ordered separately from Hukx.
mounting	Mounting with 1 or 2 clamps around the pyrhelimeter tube $\varnothing 38 \times 10^{-3}$ m, clamp to clamp distance of $120 \times 10^{-3}$ m max. Contact the factory for solar tracker compatibility.
IP protection class	IP67
desiccant	3 bags of silica gel, 1 g, $(45 \times 24 \times 4) \times 10^{-3}$ m
desiccant replacement	> 5 year interval, typically replaced during recalibration, ask the manufacturer for instructions.

## Shipping

gross weight including 5 m cable approx. 1 kg

net weight including 5 m cable approx. 1 kg

## Tracking and alignment

required tracking The instrument must be pointed at the sun center.

required alignment The pyrhelimeter and the tracker should be aligned using the pyrhelimeter sight.

rated misalignment interval  
(without impact on measurement accuracy)  $\pm 0.5^\circ$   
from the sun center, using the pyrhelimeter sight as a reference

sight resolution  $< 0.2^\circ$   
lightspot projection  $< 25\%$  off target hole

sight sensitivity  $2.5 \times 10^{-3} \text{ m}/^\circ$

## Window assembly with heater

window assembly with heater 12 VDC, 1 W

heater operation The heater is not necessarily switched on; recommended operation is to always run the heater.

heater resistance 144  $\Omega$

steady state zero offset caused by 1 W heating  $< 0.2 \text{ W}/\text{m}^2$

optional high power operation of the heater  
for use in extreme conditions 24 VDC, 4 W

steady state zero offset caused  
by high power 4 W heating  $< 0.5 \text{ W}/\text{m}^2$

## Calibration

calibration traceability	to WRR
calibration hierarchy	From WRR through ISO 9059, applying a correction to reference conditions.
calibration method	indoor comparison to a reference pyrhelimeter
calibration uncertainty	< 1.2 % (k = 2)
recommended recalibration interval	2 years
reference conditions	20 °C, horizontal mounting, irradiance level 1000 W/m <sup>2</sup>
validity of calibration	Based on experience the instrument sensitivity will not change during storage. During use under exposure to solar radiation, the instrument "non-stability" specification is applicable.

## Measurement accuracy and resolution

uncertainty of the measurement	Statements about the overall measurement uncertainty can only be made on an individual basis. See the chapter on uncertainty evaluation.
WMO estimate on achievable uncertainty for minute sums (see appendix for a definition of the measurement conditions)	1.8 %
WMO estimate on achievable uncertainty for hourly sums (see appendix for a definition of the measurement conditions)	1.5 %
WMO estimate on achievable uncertainty for daily sums (see appendix for a definition of the measurement conditions)	1.0 %

## Versions

internal temperature sensor	Measuring the body temperature: version code = T1 for Pt100 DIN class A, version code = T2 for thermistor 10 kΩ at 25 °C DR20-A1 and DR15-A1 can only be delivered as either a T1 or a T2 version. See Chapter on ordering & delivery.
-----------------------------	---

### 3.2 Dimensions of DR20-A1 / DR15-A1

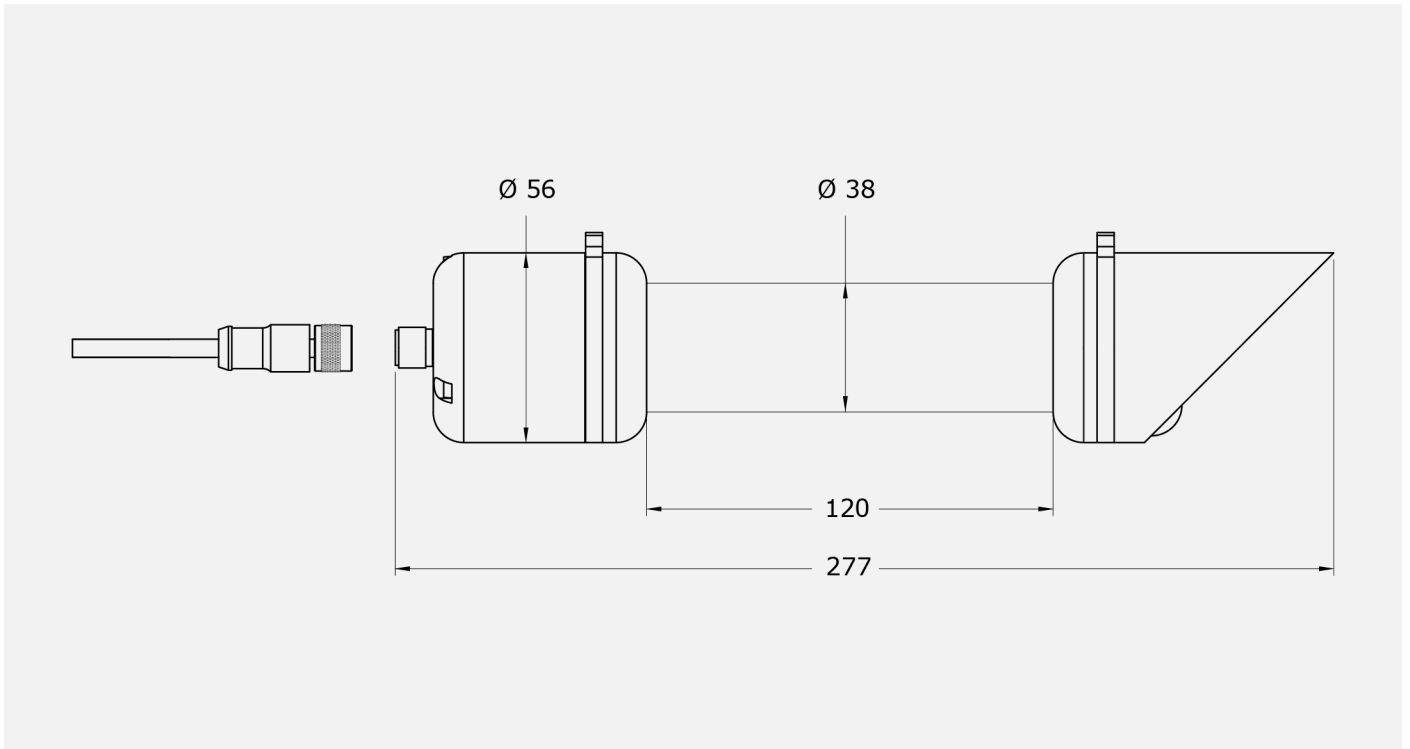

Figure 3.2.1 DR20 / DR15  
dimensions in  $\times 10^{-3}$  m.

# 4 Standards and recommended practices for use

Pyrheliometers are classified according to the ISO 9060 standard and the WMO-No. 8 *Guide to Meteorological Instruments and Methods of Observation*. In any application, the instrument should be used in accordance with the recommended practices of ISO, IEC, WMO and/or ASTM.

## 4.1 Classification standards

Table 4.1.1 Standards for pyrheliometer classification. See the appendix for definitions of pyrheliometer specifications, and a table listing the specification limits.

Standards for instrument classification		
ISO standard	equivalent ASTM standard	WMO
ISO 9060:2018 <i>Solar energy – Specification and classification of instruments for measuring hemispherical solar and direct solar radiation</i>	not available	WMO-No. 8; <i>Guide to Meteorological Instruments and Methods of Observation</i> , Chapter 7, measurement of radiation, 7.2 measurement of direct solar radiation

## 4.2 General rules for solar radiation measurement

Table 4.2.1 Standards with recommendations for instrument use in solar radiation measurement.

standards for instrument use for direct solar radiation		
ISO standard	equivalent ASTM standard	WMO
not applicable	ASTM G183-15 Standard Practice for Field Use of Pyranometers, Pyrheliometers and UV Radiometers	WMO-No. 8 <i>Guide to Meteorological Instruments and Methods of Observation</i> , chapter 7, measurement of radiation, 7.2 measurement of direct solar radiation  WCRP-121, WMO/TD-No. 1274: BSRN operations manual version 2.1-2005

### 4.3 General use for sunshine duration measurement

According to the World Meteorological Organization (WMO, 2003), sunshine duration during a given period is defined as the sum of that sub-period for which the direct solar irradiance exceeds  $120 \text{ W/m}^2$ . WMO has approved the "pyrheliometric method" to estimate sunshine duration from pyrheliometer measurements (Chapter 8 of the WMO Guide to Instruments and Observation, 2008). This implies that pyrheliometers may be used, in combination with appropriate software to determine the threshold of  $120 \text{ W/m}^2$ , to measure sunshine duration.

Table 4.3.1 Standards with recommendations for instrument use in sunshine duration measurement.

#### standards for instrument use for direct solar radiation

WMO

---

WMO-No. 8; *Guide to Meteorological Instruments and Methods of Observation*, Chapter 8, measurement of sunshine duration, 8.2.1 Pyrheliometric Method

### 4.4 Specific use in meteorology and climatology

The World Meteorological Organization (WMO) is a specialized agency of the United Nations. It is the UN system's authoritative voice on the state and behavior of the earth's atmosphere and climate. WMO publishes WMO-No. 8 *Guide to Meteorological Instruments and Methods of Observation*, in which a table is included on "level of performance" of pyrheliometers. Nowadays WMO conforms itself to the ISO classification system.

# 5 Installation of pyrheliometers

## 5.1 Site selection and installation

Table 5.1.1 Recommendations for installation of pyrheliometers.

location	The horizon should be as free from obstacles as possible. Ideally there should be no objects between the course of the sun and the instrument.
mechanical mounting/thermal insulation	Preferably use the tube for clamping the instrument. A pyrheliometer is sensitive to thermal shocks. Do not mount the instrument on objects that become very hot (black coated metal plates).
performing a representative measurement	The pyrheliometer measures the solar radiation in a limited field of view. A representative measurement requires that the instrument is accurately pointing towards the sun center. A maximum deviation of better than $0.75^\circ$ is allowed before it results in measurement errors. Use the sight of the pyrheliometer as a reference. See the chapter on uncertainty evaluation.

## 5.2 Mounting

DR20 / DR15 is typically mounted on a solar tracker using mounting brackets. The pyrheliometer has an aperture tube with dimensions fitting on common solar tracker models with  $38 \times 10^{-3}$  m tube clamps. See Chapter 3 for the dimensions of DR20 / DR15. Contact the factory for tracker compatibility.

An essential part of mounting is to align the pyrheliometer with its sights before fixating it to the tracker. When correctly aligned, the shadow of the instrument front sight should project neatly onto the rear sight throughout the day. For more details about alignment, see Appendix 8.6.

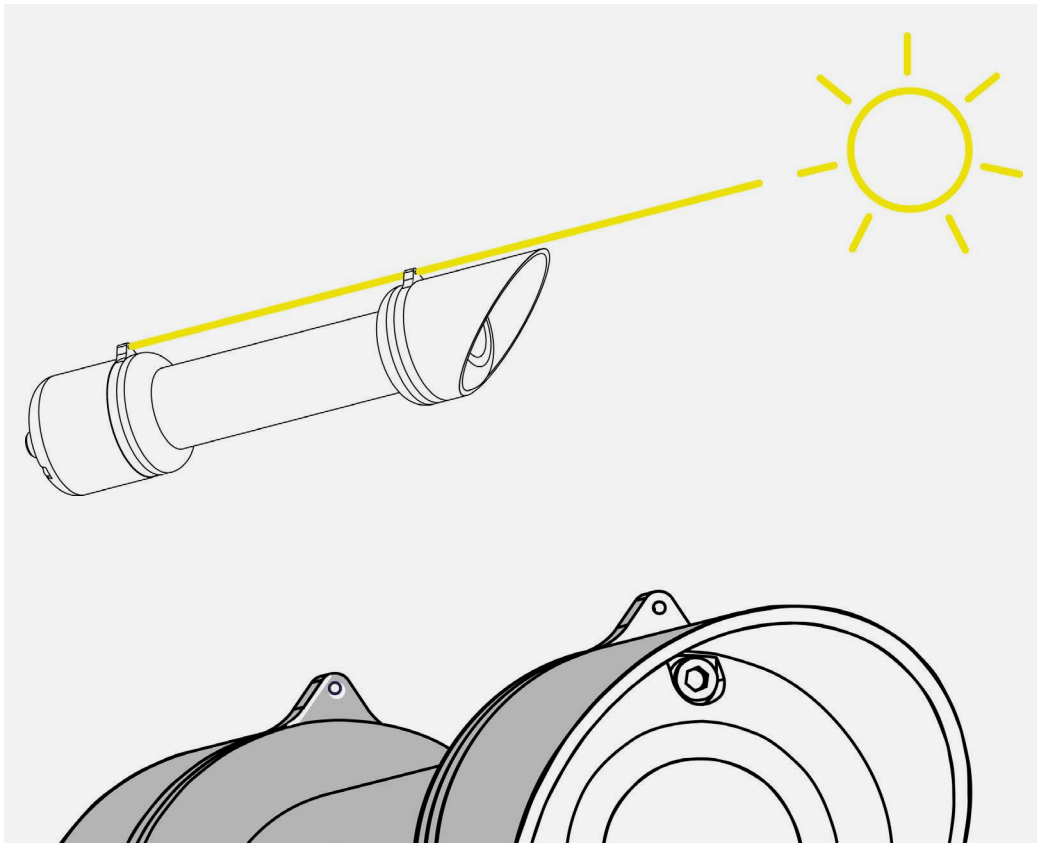

Figure 5.2.1 Aligning the DR series pyrheliometer using its sights: the shadow of the front sight should project neatly onto the rear sight throughout the day.

The alignment sights might act as capillaries and gather water, which hinders alignment. If the sights do happen to have water in them, dry them using a bit of tissue or by blowing them dry.

Alignment requires that there are no blockages between the instrument's sights. The sight dimension is such that no blockage occurs on commonly used trackers.

### 5.3 Electrical connection

In order to operate, a pyrhelimeter should be connected to a measurement system, typically a so-called data logger. DR20 / DR15 employs a passive sensor that does not need any power. In case the heater is used, it consumes 1W at 12 VDC.

Cables generally act as a source of distortion, by picking up capacitive noise.

We recommend keeping the distance between a data logger or amplifier and the sensor as short as possible. For cable extension, see the Appendix on this subject.

Table 5.3.1 Wiring diagram of DR20-A1.

PIN	wire	DR20-A1-T1	DR20-A1-T2
8	red	Pt100 [+]	10 kΩ thermistor [+]
6	pink	Pt100 [+]	10 kΩ thermistor [+]
7	blue	Pt100 [-]	10 kΩ thermistor [-]
5	gray	Pt100 [-]	10 kΩ thermistor [-]
2	brown	heater	heater
4	yellow	heater	heater
9	black	shield	shield
1	white	signal [+]	signal [+]
3	green	signal [-]	signal [-]

Table 5.3.2 Wiring diagram of DR15-A1.

PIN	wire	DR15-A1-T1	DR15-A1-T2
8	red	Pt100 [+]	10 kΩ thermistor [+]
6	pink	Pt100 [+]	10 kΩ thermistor [+]
7	blue	Pt100 [-]	10 kΩ thermistor [-]
5	gray	Pt100 [-]	10 kΩ thermistor [-]
2	brown	heater	heater
4	yellow	heater	heater
9	black	shield	shield
1	white	signal [+]	signal [+]
3	green	signal [-]	signal [-]

Note 1: Pt100's of version T1 may be connected in a 3-wire or 4-wire configuration.

Note 2: 10 kΩ thermistors of version T2 are usually connected in a 2-wire configuration.

Note 3: the heater is a resistive heater element.

Note 4: signal wires are insulated from ground wire and from the sensor body.

Insulation resistance is tested during production and larger than  $1 \times 10^6 \Omega$ .

Note 5: at the connector-end of the cable, the shield is connected to the connector chassis and thereby to the sensor housing.



Figure 5.3.1 Connector layout of DR20 / DR15 connector (male), indicating PIN numbers.

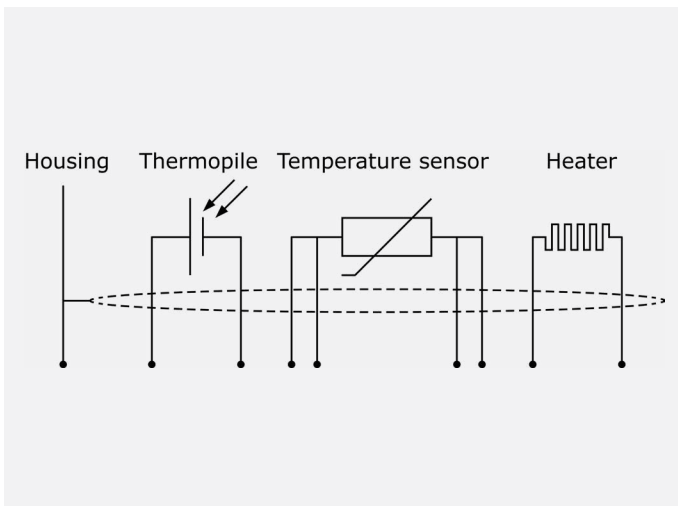

Figure 5.3.2 Electrical diagram of the internal wiring of DR20 / DR15. The shield is connected to the sensor body.

## 5.4 Grounding and use of the shield

Grounding and shield use are the responsibility of the user. The cable shield (called shield in the wiring diagram) is connected to the aluminum instrument body via the connector. In most situations, the pyrhelimeter will be mounted using mounting brackets that electrically isolate the pyrhelimeter from the solar tracker. This means there is no ground connection obtained through the instrument body, and that the shield should be connected to the local ground at the cable end. If a ground connection is obtained through the instrument body, the shield at the cable end should not be connected at all.

# 6

## Making a dependable measurement

### 6.1 The concept of dependability

A measurement with a pyrheliometer is called “dependable” if it is reliable, i.e. measuring within required uncertainty limits, for most of the time and if problems, once they occur, can be solved quickly.

The requirements for a measurement with a pyrheliometer may be expressed by the user as:

- required uncertainty of the measurement (see following paragraphs)
- requirements for maintenance and repairs (possibilities for maintenance and repair including the effort to be made and the processing time)
- a requirement to the expected instrument lifetime (until it is no longer feasible to repair)

It is important to realize that the uncertainty of the measurement is not only determined by the instrument, but also by the way it is used. See also ISO 9060 note 5. In case of pyrheliometers, the measurement uncertainty as obtained during outdoor measurements is a function of:

- the instrument class
- the calibration procedure/uncertainty
- the duration of instrument employment under natural sunlight (involving the instrument stability specification)
- the measurement conditions (such as tilting, ventilation, shading, instrument temperature)
- maintenance (cleaning of the window and verification of the alignment accuracy)
- the environmental conditions (such as atmospheric aerosol content, ambient air temperature, position of the sun, presence of clouds, horizon, representativeness of the location)\*

Therefore, ISO 9060 says, “statements on the overall measurement uncertainty can only be made on an individual basis, taking into account all relevant factors”.

\* Defined at Hukx as all factors outside the instrument that are relevant to the measurement, such as the cloud cover (presence or absence of direct radiation), sun position, the local horizon (which may be obstructed). The environmental conditions also involve the question whether or not the measurement at the location of measurement is representative of the quantity that should be measured. For pyrheliometers, the spatial distribution of circumsolar radiation, which is generated by optical scattering of direct solar radiation of the sun, may be included in uncertainty estimates. There is a contribution only in case there is a mismatch between the pyrheliometer’s acceptance function and the acceptance function defined for the measurand.

## 6.2 Reliability of the measurement

A measurement is reliable if it measures within required uncertainty limits for most of the time. We distinguish between two causes of unreliability of the measurement:

- Related to the reliability of the pyrheliometer and its design, manufacturing, calibration (hardware reliability).
- Related to the reliability of the measurement uncertainty (measurement reliability), which involves hardware reliability as well as condition of use.

Most of the hardware reliability is the responsibility of the instrument manufacturer. The reliability of the measurement, however, is a joint responsibility of instrument manufacturer and user. As a function of user requirements, taking into account measurement conditions and environmental conditions, the user will select an instrument of a certain class, and define maintenance support procedures.

In many situations, there is a limit to a realistically attainable accuracy level. This is due to conditions that are beyond control once the measurement system is in place. Typical limiting conditions are:

- The measurement conditions, for instance when working at extreme temperatures when the instrument temperature is at the extreme limits of the rated temperature range.
- The environmental conditions, for instance when installed at a sub-optimal measurement location with obstacles in the path of the sun.

The measurement reliability can be improved by maintenance.

Important aspects are:

- Window fouling by deposition of dust, dew, rain or snow. Fouling results in undefined measurement uncertainty (sensitivity and acceptance function are no longer defined). This should be solved by regular inspection and cleaning.
- Sensor instability. Maximum expected sensor aging is specified per instrument as its non-stability in [% change/year]. In case the sensor is not recalibrated, the uncertainty of the sensitivity gradually will increase. This is solved by regular recalibration.
- Moisture condensing under the pyrheliometer window resulting in a slow change of sensitivity (within specifications). This is solved by replacement of desiccant or by maintenance (drying the entire sensor). For pyrheliometers extra desiccant is available from the manufacturer.

Another way to improve measurement reliability is to introduce redundant sensors.

- The use of redundant instruments allows remote checks of one instrument using the other as a reference, which leads to a higher measurement reliability.
- Data can also be compared to measurements by local meteorological stations.
- DNI data can often be compared to pyranometer measurements (global irradiance and diffuse), assessing the uncertainty by looking if the totals match up.

## 6.3 Speed of repair and maintenance

Dependability is not only a matter of reliability, but also involves the reaction to problems; if the processing time of service and repairs is short, this contributes to the dependability.

Hukx pyrhelimeters are designed to allow easy maintenance and repair. The main maintenance actions are:

- cleaning of window
- replacement of desiccant
- replacement of cabling

For optimization of dependability, a user should:

- Design a schedule of regular maintenance.
- Design a schedule of repair or replacement in case of defects.

When operating multiple instruments in a network, Hukx recommends keeping procedures simple and having a few spare instruments to act as replacements during service, recalibrations and repair.

## 6.4 Uncertainty evaluation

The uncertainty of a measurement under outdoor or indoor conditions depends on many factors, see Paragraph 1 of this chapter. It is not possible to give one figure for pyrhelimeter measurement uncertainty. The work on uncertainty evaluation is "in progress". There are several groups around the world participating in standardization of the method of calculation. The effort aims to work according to the guidelines for uncertainty evaluation (according to the "*Guide to Expression of Uncertainty in Measurement*" or GUM)<sup>[3]</sup>.

## 6.5 Definition of the measurand

DR20 / DR15 measures direct solar radiation with an acceptance function as recommended by WMO (see also the Appendix on the terminology).

In most measurements related to meteorology, solar energy resource assessment and PV system performance monitoring, the required measurand equals the DR20 / DR15 measurand. In that case, the acceptance function is perfect and there is no contribution of the circumsolar radiation to the measurement uncertainty. However, in case the required measurand acceptance function is different from that recommended by WMO, for instance when estimating the input to Concentrated PV panels (CPV), this leads to additional measurement uncertainty. See the next paragraph of an idea of the order of magnitude.

## 6.6 Contributions from circumsolar radiation

DR20 / DR15 measures by definition direct solar radiation with an acceptance function as recommended by WMO (see also the appendix on the terminology). The measurement includes a certain amount of circumsolar radiation.

**Table 6.6.1** Contributions from the circumsolar radiation to the DNI measurement with a pyrheliometer with a 5 ° full field of view angle. The contribution is estimated for different aerosol types, different amounts of aerosol and different solar zenith angles. The total amount of aerosol is defined by spectral optical thickness at a wavelength of  $550 \times 10^{-9}$  m. Optical thicknesses are 0.05, 0.2 and 0.4 respectively. Corresponding Linke turbidity factors are 1.8, 3.4 and 5.4 respectively. Desert-type environments, not in this table, are in between urban and continental. Source: adaptation of ISO 9059:1990, Annex A, Table A1

atmospheric aerosol		solar zenith angle	DNI from the sun solar disk only	circumsolar radiation as percentage of DNI when measured with acceptance function recommended by WMO
[type]	[amount]	[°]	[W/m <sup>2</sup> ]	[%]
urban	low	30	985	0.1
	medium		872	0.3
	high		746	0.5
	low	70	736	0.1
	medium		555	0.5
	high		389	1.2
continental (background)	low	30	979	0.4
	medium		851	0.8
	high		707	1.8
	low	70	735	0.7
	medium		514	2.4
	high		328	4.1
maritime	low	30	972	0.7
	medium		826	2.8
	high		668	5.2
	low	70	711	1.6
	medium		473	6.6
	high		275	12.9

## 6.7 Instrument classification, and approaches to uncertainty evaluation

The standard covering instrument specification, ISO 9060, defines pyrheliometer classification in 4 categories or classes, according to their quality of manufacture and level of quality assurance during production.

An “accuracy class” is defined according to the International Vocabulary of Metrology VIM<sup>[4]</sup> Paragraph 4.25, as a class of measuring instruments or measuring systems that meet stated metrological requirements that are intended to keep measurement errors or instrumental uncertainties within specified limits under specified operating conditions.

Instrument manufacturers can only supply an instrument according certain specifications, with a certain initial calibration uncertainty. They are not in control of the other factors determining the measurement uncertainty. This is the user’s own responsibility.

When making an uncertainty evaluation, the general approach is laid down in GUM. The link between the classification and GUM is specified in VIM Paragraph 2.29: a way to obtain non-statistical, type B evaluation of measurement uncertainty is “obtained from the accuracy class of a verified measuring instrument”.

A user of solar radiation sensors therefore has several options:

1. To make a full analysis according to GUM, and all local circumstances; the latter is found in the following paragraph.
2. To use a generalized uncertainty evaluation based on analogy of instrument class, calibration, maintenance and environmental conditions.

## 6.8 Evaluation of measurement uncertainty under outdoor conditions

Hukx actively participates in the discussions about pyrheliometer measurement uncertainty; we also provide spreadsheets, reflecting the latest state of the art, to assist our users in making their own evaluation. Application of this spreadsheet is at the user’s own risk. The input to the assessment is summarized:

1. The formal evaluation of uncertainty should be performed in accordance with ISO 98-3 *Guide to the Expression of Uncertainty in Measurement*, GUM.
2. The specifications of the instrument according to the list of ISO 9060 classification of pyranometers and pyrheliometers are entered as limiting values of possible errors, to be analyzed as type B evaluation of standard uncertainty per Paragraph 4.3.7. of GUM. A priori distributions are chosen as rectangular.
3. A separate estimate has to be entered to allow for estimated uncertainty due to the instrument maintenance level.
4. The calibration uncertainty has to be entered. Please note that Hukx calibration uncertainties are lower than those of alternative equipment. These uncertainties are entered in measurement equation (equation is usually Formula 0.1:  $E = U/S$ ), either as an uncertainty in E (zero offsets) in U (voltage readout errors) or in S (tilt error, temperature dependence, calibration uncertainty).

5. In uncertainty analysis for pyrheliometers, the location and date of interest is entered. The course of the sun is then calculated, and the direct and diffuse components are estimated, based on a model.
6. In uncertainty analysis for modern pyrheliometers: tilt dependence often is so low that one single typical observation may be sufficient.
7. In case of special measurement conditions, typical specification values are chosen. These should, for instance, account for the measurement conditions and environmental conditions (clear sky/cloudy, working temperature range).
8. Among the various sources of uncertainty, some are "correlated"; i.e. present during the entire measurement process, and not cancelling or converging to zero when averaged over time; the off-diagonal elements of the covariance matrix are not zero. Paragraph 5.2 of GUM.
9. Among the various sources of uncertainty, some are "uncorrelated"; cancelling or converging to zero when averaged over time; the off-diagonal elements of the covariance matrix are zero. Paragraph 5.1 of GUM.
10. Among the various sources of uncertainty, some are "not included in analysis"; this applies for instance to the spectral response for pyranometers and pyrheliometers, because it is already taken into account in the calibration process.
11. In case the required measurand acceptance function is different from that recommended by WMO, for instance, when estimating the input to Concentrated PV panels (CPV), this leads to additional measurement uncertainty.

The following two tables show results by Hukx and WMO; the latter without entering calibration uncertainty.

**Table 6.8.1** Estimates of achievable uncertainties of measurements with pyrheliometers. The estimates are based on the ISO 9060:2018 specification limits and a calibration uncertainty of 1.5 %, for sunny, clear sky days and well-maintained stations, without uncertainty loss due to lack of maintenance and due to instrument fouling. The table specifies expanded uncertainties with a coverage factor of 2 and a confidence level of 95 %. Estimates are based on 1 s sampling. IMPORTANT NOTE: there is no international consensus on uncertainty evaluation of pyrheliometer measurements, so this table should not be used as a formal reference (continued on next page).

<b>pyrheliometer class (ISO 9060)</b>	<b>season</b>	<b>AOD</b>	<b>uncertainty minute totals at solar noon</b>	<b>uncertainty hourly totals at solar noon</b>	<b>uncertainty daily totals</b>
DR20 (Class A)	summer	mid-latitude	1.3 %	1.3 %	1.3 %
		equator	1.3 %	1.2 %	1.3 %
		pole	1.3 %	1.2 %	1.3 %
	winter	mid-latitude	1.3 %	1.3 %	1.4 %
		equator	1.4 %	1.4 %	1.4 %
		pole	1.4 %	1.4 %	1.4 %
Class A	summer	mid-latitude	1.4 %	1.4 %	1.5 %
		equator	1.4 %	1.4 %	1.4 %
		pole	1.4 %	1.4 %	1.4 %
	winter	mid-latitude	1.4 %	1.4 %	1.5 %

DR15 (Class B)	summer	mid-latitude	1.6 %	1.6 %	1.7 %
		equator	1.6 %	1.6 %	1.6 %
		pole	1.6 %	1.6 %	1.6 %
	winter	mid-latitude	1.6 %	1.6 %	1.7 %
		equator	1.6 %	1.6 %	1.6 %
		pole	1.6 %	1.6 %	1.6 %
Class B	summer	mid-latitude	2.6 %	2.6 %	2.8 %
		equator	2.5 %	2.5 %	2.7 %
		pole	2.5 %	2.5 %	2.6 %
	winter	mid-latitude	2.5 %	2.5 %	2.9 %

**Table 6.8.2** Estimate of achievable uncertainties of measurements with good quality pyrheliometers according to WMO-No. 8, seventh edition, 2008. Copy from WMO Guide 7.2.1: The estimated uncertainties are based on the following assumptions: (a) Instruments are well-maintained, correctly aligned and clean; (b) 1 min and 1 h figures are for clear-sky irradiances at solar noon; (c) Daily exposure values are for clear days at mid-latitudes. IMPORTANT NOTE: According to 7.3.2.5 the achievable uncertainty does not include any calibration errors. IMPORTANT NOTE: Achievable accuracy is not part of the GUM vocabulary.

interval	achievable uncertainty
achievable uncertainty (95% confidence level) daily totals	± 1.0 %
achievable uncertainty (95% confidence level) hourly totals	± 1.5 %
achievable uncertainty (95% confidence level) minute totals	± 1.8 %

## 6.9 Calibration uncertainty

Our latest calibration method results in an uncertainty of the sensitivity of less than 1.2 %. The user may receive an instrument with a lower uncertainty. See the calibration report for the exact value.

# 7 Maintenance and trouble shooting

## 7.1 Recommended maintenance and quality assurance

DR20 / DR15 is typically used for high-accuracy measurements and cannot measure reliably at a low level of maintenance. As a general rule, this means that regular cleaning of the window and visual inspection of alignment accuracy combined with a critical review of the measured data, preferably checking against other measurements, is the preferred way to obtain a reliable measurement.

Table 7.1.1 Recommended maintenance of DR20 / DR15. If possible the data analysis, tracker inspection and cleaning (1 and 2) should be done on a daily basis (continued on next page).

minimum recommended pyrheliometer maintenance			
	interval	subject	action
1	0.5 week	cleaning	Use a soft cloth to clean the window of the instrument, persistent stains can be treated with soapy water or alcohol.
		tracking	Inspect tracking and alignment, make adjustments if necessary.
2	1 week	data analysis	Compare measured data to maximum possible/ maximum expected irradiance and to other measurements nearby (redundant instruments). Also, historical seasonal records can be used as a source for expected values. Analyze night time signals. These should be close to zero. Check for any patterns and events that deviate from what is normal or expected.
3	6 months	inspection	Inspect cable quality, inspect cable connectors, inspect mounting position, inspect cable, clean instrument, clean cable, inspect leveling, inspect mounting connection, inspect interior of window for condensation.
4	2 years	recalibration	Recalibration by side-by-side comparison to a higher standard instrument in the field according to ISO 9059.
5		lifetime assessment	Judge if the instrument should be reliable for another 2 years, or if it should be replaced.

6	> 5 years	desiccant replacement	desiccant replacement
7		parts replacement	If applicable/necessary replace the parts that are most exposed to weathering; cable, protection cap. NOTE: use Hukx approved parts only.

## 7.2 Trouble shooting

Table 7.2.1 Trouble shooting for DR20 / DR15 (continued on next pages).

general	<p>Inspect the instrument for any damage.</p> <p>Inspect if the connector is properly attached.</p> <p>Check the condition of the connectors (on chassis as well as the cable).</p>
The sensor does not give any signal.	<p>Verify that the solar tracker operates normally and the instrument is properly aligned. Verify that the sensor has an unobstructed line of sight to the sun.</p> <p>Check the electrical resistance of the sensor between the green (-) and white (+) wire. Use a multimeter at the 1000 <math>\Omega</math> range. Measure the sensor resistance first with one polarity, than reverse the polarity. Take the average value. The typical resistance of the wiring is 0.1 <math>\Omega</math>/m. Typical resistance should be the typical sensor resistance of 50 to 100 <math>\Omega</math> (150 plus 1.5 <math>\Omega</math> for the total resistance of two wires (back and forth) of each 5 m. Infinite resistance indicates a broken circuit; zero or a low resistance indicates a short circuit.</p> <p>Check if the sensor reacts to light: put the multimeter at its most sensitive range of DC voltage measurement, typically the 100 x 10<sup>-3</sup> VDC range or lower. Expose the sensor to strong light source, for instance a 100 W light bulb at the front window. The signal should read &gt; 2 x 10<sup>-3</sup> V now. Darken the sensor either by putting something over it or switching off the light. The instrument voltage output should go down and within one minute approach 0 V.</p> <p>Check the data acquisition by applying a 1 x 10<sup>-6</sup> V source to it in the 1 x 10<sup>-6</sup> V range. Check if the output is as expected.</p>

The sensor signal is unrealistically high or low.

Note that nighttime signals may be negative due to zero offset a.  
Note that nighttime signals may be slightly positive (up to  $0.2 \text{ W/m}^2$  at low power, up to  $0.5 \text{ W/m}^2$  at high power) when heating.  
Check if the pyrhelimeter has a clean window.  
Check the tracking accuracy in the presence of sun. The dot projected by the sight on the target hole should be no more than 50 % off target (the dot has a  $2 \times 10^{-3} \text{ m}$  diameter, the target hole also has a  $2 \times 10^{-3} \text{ m}$  diameter; 50 % off target means that half the dot is projected outside the target hole).  
Check if the right calibration factor is entered into the algorithm.  
Please note that each sensor has its own individual calibration factor, as documented on its calibration certificate.  
Check if the voltage reading is divided by the calibration factor in review of the algorithm.  
Check the condition of the wiring at the logger.  
Check the cable condition looking for cable breaks.  
Check the range of the data logger; signal can be negative (this could be out of range) or the amplitude could be out of range.  
Check the data acquisition by applying a  $1 \times 10^{-6} \text{ V}$  source to it in the  $1 \times 10^{-6} \text{ V}$  range. Look at the output. Check if the output is as expected.  
Check the data acquisition by short circuiting the data acquisition input with a  $100 \Omega$  resistor. Look at the output. Check if the output is close to  $0 \text{ W/m}^2$ .  
In case of applying a temperature correction with DR20, check your resistance measurement and calculations. See the appendix on converting resistance to temperature.

The sensor signal shows unexpected variations.

Check the presence of strong sources of electromagnetic radiation (radar, radio).  
Check the condition and connection of the shield.  
Check the condition of the sensor cable.  
Check if the cable is not moving during the measurement.  
Check the condition of the connectors (on chassis as well as the cable)

The instrument shows internal condensation.

Arrange to send the sensor to the manufacturer for diagnosis and service.

## 7.3 Calibration and checks in the field

Recalibration of field pyrheliometers is typically done by comparison in the field to a reference pyrheliometer. The applicable standard is ISO 9059 "*Solar Energy — calibration of field pyrheliometers by comparison to a reference pyrheliometer*".

At Hukx, an indoor calibration according to the same standard is used.

In case of field comparison; ISO allows use of sensors of the same class.

Hukx recommends also using the same model, because an intercomparison of similar instruments has the advantage that they suffer from the same offsets and contributions of circumsolar radiation.

ISO recommends to perform field calibration during several days; 2 to 3 days under cloudless conditions. In order to limit the influence of turbidity and aerosols, Hukx suggests using hourly totals near solar noon.

Hukx's main recommendations for field intercomparisons are:

1. To take high solar irradiance measurements at solar noon as a reference and not the entire day.
2. To take a reference of the same brand and type as the field pyrheliometer or a pyrheliometer of a higher class.
3. To connect both to the same electronics, so that electronics errors (also offsets) are eliminated.
4. To mount all instruments on the same tracker.
5. To correct deviations of more than  $\pm 0.2\%$ . Lower deviations should be interpreted as acceptable and should not lead to a revised sensitivity.

## 7.4 Data quality assurance

Quality assurance can be done by:

- Analyzing trends in solar irradiance signal.
- Plotting the measured irradiance against mathematically generated expected values.
- Comparing irradiance measurements between sites.
- Analysis of nighttime signals.

The main idea is that one should look out for any unrealistic values.

See for example:

C.N. Long and Y. Shi, [An Automated Quality Assessment and Control Algorithm for Surface Radiation Measurements](#), The Open Atmospheric Science Journal, 2008, 2: pp. 23–37

# 8 Appendices

## 8.1 Appendix on cable extension/replacement

The sensor cable of DR20 / DR15 has a length of 5 m and is equipped with a M12-A straight connector. In case of cable replacement, it is recommended to purchase a new cable with connector at Hukx.

In case of cable extension, it is recommended to use the specifications given in Table 8.1.1. Please contact the factory for further instructions. Please note that Hukx does not provide support for Do-It-Yourself connector and cable assembly.

Cables act as a source of distortion by picking up capacitive noise. In an electrically "quiet" environment the DR20 / DR15 cable can however be extended without problem to 100 meters. If done properly, the sensor signal, although small, will not significantly degrade because the sensor resistance is very low (so good immunity to external sources) and because there is no current flowing (so no resistive losses).

Connector, cable, and cable connection specifications are summarized below.

Table 8.1.1 Preferred specifications for cable extension of DR20 / DR15 .

general replacement	Please order a new cable with connector at Hukx.
connectors used	chassis: M12-A straight male connector, male thread, 8-pole manufacturer: Binder cable: M12-A straight female connector, female thread, 8-pole manufacturer: Binder The shield is electrically connected to the connector housing.
cable	8-wire, shielded manufacturer: Binder
length	Cables should be kept as short as possible, in any case, the total cable length should be less than 100 m.
outer jacket	with specifications for outdoor use (for good stability in outdoor applications)

## 8.2 Appendix on tools for DR20-A1 / DR15-A1

Table 10.2.1 Specifications of tools for DR20 / DR15.

Tooling required for window assembly and backside fixation and removal.	hex key 2.5 mm
Tooling required for desiccant holder fixation and removal.	torx TX 8; please contact the factory for detailed instructions

## 8.3 Appendix on spare parts for DR20-A1 / DR15-A1

- 5 meters cable for DR20 / DR15, with female M12-A connector at sensor end, pigtails of 0.15 m and conductors with ferrules
- desiccant for DR20 / DR15 (silica gel, 3 x 1 g, in an HDPE bag)

NOTE: Glass window, thermopile sensor and internal sensors of DR20 / DR15 cannot be supplied as spare parts. In case of damage to the DR20 / DR15, after repair the instrument must be tested to verify performance within specification limits. This is required by ISO 9060. Testing involves verification of the temperature response (DR20 only) and response time after thermal sensor replacement.

## 8.4 Appendix on standards for classification and calibration

Both ISO and ASTM have standards on instrument classification and methods of calibration. The World Meteorological Organization (WMO) has largely adopted the ISO classification system.

Table 8.4.1 Pyrheliometer standardization in ISO and ASTM.

Standards on instrument classification and calibration	
ISO standard	equivalent ASTM standard
<p>ISO 9060:2018 <i>Solar energy — Specification and classification of instruments for measuring hemispherical solar and direct solar radiation</i></p>	<p>not available Comment: work is in progress on a new ASTM equivalent standard.</p>
<p>Comment: a standard <i>Solar energy — Methods for testing pyranometer and pyrheliometer characteristics</i> has been announced in ISO 9060 but is not yet implemented.</p>	<p>not available</p>
<p>ISO 9846:1993 <i>Solar energy — Calibration of a pyranometer using a pyrheliometer</i></p>	<p>ASTM G167-15 — <i>Standard Test Method for Calibration of a Pyranometer Using a Pyrheliometer</i></p>
<p>ISO 9847:1992 <i>Solar energy — Calibration of field pyranometers by comparison to a reference pyranometer</i></p>	<p>ASTM E824-10 — <i>Standard Test Method for Transfer of Calibration from Reference to Field Radiometers</i></p> <p>ASTM G207-11 — <i>Standard Test Method for Indoor Transfer of Calibration from Reference to Field Pyranometers</i></p>
<p>ISO 9059:1990 <i>Solar energy — Calibration of field pyrheliometers by comparison to a reference pyrheliometer</i></p>	<p>ASTM E816-15 — <i>Standard Test Method for Calibration of Pyrheliometers by Comparison to Reference Pyrheliometers</i></p>

## 8.5 Appendix on calibration hierarchy

The World Radiometric Reference (WRR) is the measurement standard representing the SI unit of irradiance. Use of WRR is mandatory when working according to the standards of both WMO and ISO. ISO 9847 states under Paragraph 1.3: the methods of calibration specified are traceable to the WRR. The WMO manual states under Paragraph 71.2.2: the WRR is accepted as representing the physical units of total irradiance.

The worldwide homogeneity of the meteorological radiation measurements is guaranteed by the World Radiation Center in Davos Switzerland, by maintaining the World Standard Group (WSG) which materializes the World Radiometric Reference.

See [www.pmodwrc.ch](http://www.pmodwrc.ch)

The Hukx standard is traceable to an outdoor WRR calibration. During the outdoor calibration the sun is typically at 20 to 60° zenith angle, and the total irradiance at a 700 to 900 W/m<sup>2</sup> level.

Table 8.5.1 Calibration hierarchy for pyrhemometers.

### Working standard calibration at pmod/wrc davos

Calibration of working standard pyrhemometers:

Method: ISO 9059, outdoor. This working standard has an uncertainty "uncertainty of standard".

The working standard has been calibrated under certain "test conditions of the standard".

The working standard has traceability to WRR world radiometric reference.

### Correction of (working) standard calibration to standardized reference conditions

Correction from "test conditions of the standard" to "reference conditions" i.e. to horizontal position and 20 °C, using known (working) standard pyrhemometer properties: non-linearity, offsets, temperature dependence). This correction has an uncertainty; "uncertainty of correction".

At Hukx, we call the working standard pyrhemometer "standard".

### Indoor product calibration

Calibration of product, i.e. pyrhemometers:

Method: Calibration according to Hukx internal procedure DRC.

This method employs solar radiation generated by a lamp source.

This calibration has an uncertainty associated with the method.

### Calibration uncertainty evaluation

ISO 98-3 *Guide to the Expression of Uncertainty in Measurement*, GUM Determination of combined expanded uncertainty of calibration of the product, including uncertainty of the working standard, uncertainty of correction, uncertainty of the method (transfer error). The coverage factor must be determined; at Hukx we work with a coverage factor  $k = 2$ .

## 8.6 Appendix on requirements for solar tracking

For a correct measurement, the DR20 / DR15 pyrhelimeter should be pointed at the sun. It is usually mounted on a solar tracker. Theoretically, the alignment accuracy of a pyrhelimeter should be better than the slope angle minus the full angle of the solar disk, i.e. within  $0.5^\circ$ . However, in practice, a wider misalignment interval may be tolerated. ISO 9059:1990 Paragraph 5.3.2 specifies that a misalignment of the slope angle minus  $0.25^\circ$  is permitted. With Hukx pyrhelimeters, that would allow  $0.75^\circ$  pointing error, which is rounded off to  $< 0.7^\circ$ . An independent simulation in the BSRN operations manual (Figure 4.7) indicates that a pointing error of  $< 0.7^\circ$  does not lead to significant measurement errors.

During production at the factory, the optical axis of the pyrhelimeter is aligned with its sights. In outdoor operation, the tracker is on its turn aligned along the zenith axis with its own level, and in the azimuth direction with the pyrhelimeter sights. The latter is typically done using the sun as a source. The resolution (i.e. the ability to meaningfully distinguish between measurement results) of the DR20 / DR15 sights is  $0.2^\circ$ . This means that if the pyrhelimeter sight is used as a reference, the tracking accuracy should remain within  $0.5^\circ$ .

Hukx therefore specifies a rated misalignment interval (i.e. without impact on pyrhelimeter measurement accuracy) of  $\pm 0.5^\circ$  from the sun center using the pyrhelimeter sight as a reference.

Some trackers employ active control with a sun sensor:

The BSRN operations manual in 2.2.1.1 recommends a tracker with a 4-quadrant sun sensor. The tracker accuracy is recommended to be  $< 0.1^\circ$ . However, this is not a requirement for pyrhelimeters, which can operate with a  $0.75^\circ$  pointing error or a  $0.5^\circ$  detectable misalignment. Verbal communication with the editor of the BSRN manual, B. Forgan, in October 2015 confirmed that the specified tracking accuracy is a requirement for operation of sun photometers. The BSRN manual will be adapted to correct this mistake.

In case a sun sensor is used, this sensor typically controls tracking as soon as the direct solar irradiance is above a certain level. In that case, the pyrhelimeters should be aligned with the sun sensor, and the rated solar tracking range, defined for passive tracking based on calculation, may be relaxed. In case we use a sun sensor with  $< 0.1^\circ$  misalignment, this is much better than required for pyrhelimeters. Please note that sun sensors must be regularly cleaned to be dependable. The 4-quadrant type sun sensor also needs regular recalibration to make sure that the individual drift of the 4 quadrants is compensated for.

## 8.7 Appendix on meteorological radiation quantities

A pyrliometer measures irradiance. The time integrated total is called radiant exposure. In solar energy radiant exposure is often given in  $W \cdot h/m^2$ .

Table 8.71 Meteorological radiation quantities as recommended by WMO (additional symbols by Hukx). POA stands for Plane of Array irradiance. The term originates from ASTM and IEC standards.

symbol	description	calculation	units	alternative expression	
$E_{\downarrow}$	downward irradiance	$E_{\downarrow} = E_{g\downarrow} + E_{l\downarrow}$	$W/m^2$		
$H_{\downarrow}$	downward radiant exposure for a specified time interval	$H_{\downarrow} = H_{g\downarrow} + H_{l\downarrow}$	$J/m^2$	$W \cdot h/m^2$	change of units
$E_{\uparrow}$	upward irradiance	$E_{\uparrow} = E_{g\uparrow} + E_{l\uparrow}$	$W/m^2$		
$H_{\uparrow}$	upward radiant exposure for a specified time interval	$H_{\uparrow} = H_{g\uparrow} + H_{l\uparrow}$	$J/m^2$	$W \cdot h/m^2$	change of units
$E$	direct solar irradiance normal to the apparent solar zenith angle		$W/m^2$	DNI	Direct Normal Irradiance
$E_0$	solar constant		$W/m^2$		
$E_{g\downarrow h}$	global irradiance; hemispherical irradiance on a specified, in this case, horizontal surface*	$E_{g\downarrow} = E \cdot \cos \theta_h + E_{d\downarrow}$	$W/m^2$	GHI	Global Horizontal Irradiance
$E_{g\downarrow t}$	global irradiance; hemispherical irradiance on a specified, in this case, tilted surface*	$E_{g\downarrow} = E \cdot \cos \theta_t + E_{d\downarrow t} + E_{l\uparrow t}$ ***	$W/m^2$	POA	Plane of Array irradiance
$E_{d\downarrow}$	downward diffuse solar radiation		$W/m^2$	DHI	Diffuse Horizontal Irradiance
$E_{l\uparrow}, E_{l\downarrow}$	upward/downward longwave irradiance		$W/m^2$		
$E_r$	reflected solar irradiance		$W/m^2$		
$E^*$	net irradiance	$E^* = E_{\downarrow} - E_{\uparrow}$	$W/m^2$		
$T_{\downarrow}$	apparent surface temperature**		$^{\circ}C$ or $K$		
$T_{\uparrow}$	apparent sky temperature**		$^{\circ}C$ or $K$		
SD	sunshine duration		h		

$\theta$  is the apparent solar zenith angle  $\theta_h$  relative to horizontal,  $\theta_t$  relative to a tilted surface  
g = global, l = long wave, t = tilted \*, h = horizontal\*

\* distinction horizontal and tilted from Hukx,  
\*\* T symbols introduced by Hukx,  
\*\*\* contributions of  $E_{d\downarrow t}$  and  $E_{l\uparrow t}$  are  $E_{d\downarrow}$  and  $E_{l\uparrow}$  both corrected for the tilt angle of the surface

## 8.8 Appendix on ISO and WMO classification tables

**Table 8.8.1** Valid classification table for pyrheliometers per ISO 9060:2018 and WMO.

NOTE: WMO specification of spectral selectivity is different from that of ISO. Hukx conforms to the ISO limits. WMO also specifies expected accuracies. ISO finds this not to be a part of the classification system, because it also involves calibration. Please note that WMO achievable accuracies are for clear days at mid latitudes and that the uncertainty estimate does not include uncertainty due to calibration\*.

<b>ISO 9060:2018 classification** table</b>			
<b>ISO accuracy class</b>	<b>Class A</b>	<b>Class B</b>	<b>Class C</b>
specification acceptance interval (guard band)			
response time (95 %)	10 s (1 s)	15 s (1 s)	20 s (1 s)
zero offset a (response to 5 K/h in ambient temperature)	± 1 W/m <sup>2</sup> (0.5 W/m <sup>2</sup> )	± 3 W/m <sup>2</sup> (0.5 W/m <sup>2</sup> )	± 6 W/m <sup>2</sup> (1 W/m <sup>2</sup> )
complete zero offset	± 2 W/m <sup>2</sup> (0.5 W/m <sup>2</sup> )	± 4 W/m <sup>2</sup> (0.5 W/m <sup>2</sup> )	± 7 W/m <sup>2</sup> (1 W/m <sup>2</sup> )
non-stability (change per year)	± 0.5 % (0.25 %)	± 1 % (0.25 %)	± 2 % (0.25 %)
non-linearity (100 to 1 000 W/m <sup>2</sup> )	± 0.2 % (0.1 %)	± 0.5 % (0.2 %)	± 23 % (0.5 %)
for spectrally flat subcategory only: spectral selectivity (350 to 1 500 x 10 <sup>-9</sup> m) (WMO 300 to 3 000 x 10 <sup>-9</sup> m)	± 3 % (2 %)	± 3 % (2 %)	± 3 % (2 %)
clear sky direct normal irradiance spectral error	± 0.2 % (0.05 %)	± 1 % (0.5 %)	± 2 % (1 %)
temperature response (interval -10 to + 40° C relative to 20 °C)**	± 0.5 % (0.25 %)	± 1 % (0.5 %)	± 5 % (0.5 %)
tilt response (0 to 180 ° at 1000 W/m <sup>2</sup> )	± 0.2 % (0.2 %)	± 0.52 % (0.2 %)	± 2 % (0.5 %)
additional signal processing errors	± 1 W/m <sup>2</sup> (0.5 W/m <sup>2</sup> )	± 5 W/m <sup>2</sup> (2 W/m <sup>2</sup> )	± 10 W/m <sup>2</sup> (2 W/m <sup>2</sup> )
conformity testing**	temperature test for every individual instrument	group compliance	group compliance
for fast response subclass only: response time (95 %)	0.5 s	0.5 s	0.5 s

## iso tracking recommendations\*\*

rated non-alignment interval (without impact on measurement accuracy) for 1 ° slope angle	< 0.75 ° from the sun center	< 0.75 ° from the sun center	< 0.75 ° from the sun center
---	------------------------------	------------------------------	------------------------------

## Additional WMO specifications

interval	achievable uncertainty good quality pyrheliometers
achievable uncertainty (95% confidence level) daily totals	± 1.0 %
achievable uncertainty (95% confidence level) hourly totals	± 1.5 %
achievable uncertainty (95% confidence level) minute totals	± 1.8 %

\* WMO 7.2.1: The estimated uncertainties are based on the following assumptions: (a) instruments are well-maintained, correctly aligned and clean; (b) 1 min and 1 h figures are for clear-sky irradiances at solar noon; (c) daily exposure values are for clear days at mid-latitudes. WMO 7.3.2.5: Table 7.5 lists the expected maximum deviation from the true value, excluding calibration errors.

\*\* ISO 9060:2018: an instrument is subject to conformity testing of its specifications. The classification of pyrheliometers may be applied to individual instruments or to groups (particular types) of instruments, depending on the category. A pyrheliometer type (pyrheliometers of identical design) may be claimed to be of a particular class even without individual tests depending on the class if the appropriate quality control has shown that pyrheliometers of this type comply with the respective specifications. However, a highest class (class A) instrument may only be designated as such on an individual basis. For the classification of a

pyrheliometer in the second highest class (class A), individual tests of temperature response are required. A specification is fulfilled if: a) the value of the respective test result lies in the corresponding acceptance interval given in Table 1 for the specific class of instrument; and if b) the sum of the absolute amounts of the expanded uncertainty of the test and the test result is less or equal to the absolute amount of the limit of the tolerance interval (guarded acceptance) — the tolerance interval is determined by the acceptance interval and the guard bands from iso 9060: 2018 table 1 (same as 10.8.1). Reference: JCGM 106 and ISO /IEC Guide 98-4 *Uncertainty of measurement* — Part 4: Role of measurement uncertainty in conformity assessment

\*\*\* ISO 9059 Solar energy — *Calibration of field pyrheliometers by comparison to a reference pyrheliometer* Paragraph 5.3.2 allows slope angle minus 0.25 °, which is rounded off to 0.7 °. See also Appendix 8.6 on requirements for tracking.

## 8.9 Appendix on ISO 9060:1990 classification no longer valid

Table 8.9.1 No longer valid: classification table for pyranometers per ISO 9060:1990. For valid table see 10.8.

Old ISO 9060:1990 classification table, no longer valid			
ISO category	Secondary standard	First class	Second class
specification limit			
response time (95 %)	< 15 s	< 20 s	< 30 s
zero offset (response to 5 K/h in ambient temperature)	± 1 W/m <sup>2</sup>	± 3 W/m <sup>2</sup>	± 6 W/m <sup>2</sup>
non-stability (change per year)	± 0.5 %	± 1 %	± 2 %
non-linearity (100 to 1000 W/m <sup>2</sup> )	± 0.2 %	± 0.5 %	± 2 %
spectral selectivity (350 to 1500 x 10 <sup>-9</sup> m)	± 0.5 %	± 1 %	± 5 %
temperature response (interval of 50 K)	± 1 %	± 2 %	± 10 %
tilt response (0 to 90 ° at 1000 W/m <sup>2</sup> )	± 0.2 %	± 0.5 %	± 2 %
conformity testing**	individual instrument only: all specs must comply	group compliance	group compliance

\* ISO 9060:1990 an instrument is subject to conformity testing of its specifications. Depending on the classification, conformity compliance can be proven either by group or individual compliance. A specification is fulfilled if the mean value of the respective test result does not exceed the corresponding limiting value of the specification for the specific category of instrument.

## 8.10 Appendix on the definition of pyrheliometer specifications

Table 8.10.1 Definition of pyrheliometer specifications.

specification	definition	source
response time (95 %)	Time for 95 % response. The time interval between the instant when a stimulus is subjected to a specified abrupt change and the instant when the response reaches and remains within specified limits around its final steady value. The response time is a measure of the thermal inertia inherent in the stabilization period for a final reading.	ISO 9060:2018 WMO 1.6.3
zero offset a: (5 K/h in ambient temperature)	Response to 5 K/h change in ambient temperature. Zero offsets are a measure of the stability of the zero-point.	ISO 9060:2018
complete zero offset	Including the effect of zero offset a and other source.	ISO 9060:2018
non-stability (change per year)	Percentage change in sensitivity per year. The dependence of sensitivity resulting from ageing effects which is a measure of the long-term stability.	ISO 9060:2018
non-linearity (100 to 1000 W/m <sup>2</sup> )	Percentage deviation from the sensitivity at 500 W/m <sup>2</sup> due to the change in irradiance within the range of 100 W/m <sup>2</sup> to 1000 W/m <sup>2</sup> . Non-linearity has an overlap with directional response, and therefore should be handled with care in uncertainty evaluation.	ISO 9060:2018
spectral selectivity (350 to 1500 x 10 <sup>-9</sup> m) (WMO 300 to 3000 x 10 <sup>-9</sup> m)	Percentage deviation of the product of spectral absorptance and spectral transmittance from the corresponding mean within the specified spectral range. Spectral selectivity is a measure of the spectral selectivity of the sensitivity.	ISO 9060:2018
clear-sky direct normal irradiance error	Maximum spectral error observed for a set of direct normal irradiance clear sky spectra defined in ISO 9060:2018.	ISO 9060:2018
temperature response	Percentage deviation due to change in ambient temperature within the interval from -10 to +40 °C relative to the signal at 20 °C.	ISO 9060:2018
tilt response (0 ° to 90 ° at 1000 W/m <sup>2</sup> )	percentage deviation from the sensitivity at 0 ° tilt (horizontal) due to change in tilt from 0 ° to 90 ° at 1000 W/m <sup>2</sup> irradiance. Tilt response describes changes of the sensitivity due to changes of the tilt angle of the receiving surface.	ISO 9060:2018

additional signal processing errors	The additional signal processing errors contain data acquisition and analog to digital conversion that might be carried out in the instrument and all other processing steps carried out within the instrument that are not covered by the other specifications.	ISO 9060:2018
sensitivity	The change in the response of a measuring instrument divided by the corresponding change in the stimulus.	WMO 1.6.3
spectral range	The spectral range of radiation to which the instrument is sensitive. For a normal pyrheliometer, this should be in the 0.3 to $3 \times 10^{-6}$ m range. Some pyrheliometers with colored glass windows have a limited spectral range.	Hukx
full field of view angle	Also opening angle: twice the angle between the center of the sensor and the view limiting front aperture, $2 \arctan (r_a/L)$ with $r_a$ the radius of the aperture at the front window and L the distance sensor to aperture.	Hukx
slope angle	The angle from the sensor edge to the view limiting front aperture at the same side, $\arctan [(r_a - r_s)/L]$ with $r_a$ the radius of the aperture, $r_s$ the radius of the sensor, and L the distance sensor to aperture.	Hukx
limit angle	The angle from the sensor edge to the view limiting front aperture at the opposite side. (ref: IEA SHC #46 and EU FP7 MACC-II projects, published by Blanc et al. 2014).	Hukx

## 8.11 Appendix on terminology/glossary

Table 8.11.1 Definitions and references of used terms.

term	definition (reference)
solar energy or solar radiation	Solar energy is the electromagnetic energy emitted by the sun. Solar energy is also called solar radiation and shortwave radiation. The solar radiation incident on the top of the terrestrial atmosphere is called extra-terrestrial solar radiation; 97 % of which is confined to the spectral range of $(290 \text{ to } 3\,000) \times 10^{-9} \text{ m}$ . Part of the extra-terrestrial solar radiation penetrates the atmosphere and directly reaches the earth's surface, while part of it is scattered and/or absorbed by the gas molecules, aerosol particles, cloud droplets and cloud crystals in the atmosphere. The former is the direct component, the latter is the diffuse component of the solar radiation. (ref: WMO, Hukx).
hemispherical solar radiation	Solar radiation received by a plane surface from a $180^\circ$ field of view angle (solid angle of $2\pi \text{ sr}$ ) (ref: ISO 9060).
global solar radiation	The solar radiation received from a $180^\circ$ field of view angle on a horizontal surface is referred to as global radiation. Also called GHI. This includes radiation received directly from the solid angle of the sun's disc, as well as diffuse sky radiation that has been scattered in traversing the atmosphere (ref: WMO). Hemispherical solar radiation received by a horizontal plane surface (ref: ISO 9060).
Plane of Array irradiance	Also POA: hemispherical solar irradiance in the plane of a PV array (ref: ASTM E2848-13 / IEC 61724).
direct solar radiation	Radiation received from a small solid angle centered on the sun's disc, on a given plane (ref: ISO 9060).
terrestrial or longwave radiation	Radiation not of solar origin but of terrestrial and atmospheric origin and having longer wavelengths ( $3\,000 \text{ to } 100\,000 \times 10^{-9} \text{ m}$ ). In case of downwelling $E_{\downarrow}$ , also the background radiation from the universe is involved, passing through the "atmospheric window". In case of upwelling $E_{\uparrow}$ , composed of longwave electromagnetic energy emitted by the earth's surface and by the gases, aerosols and clouds of the atmosphere; it is also partly absorbed within the atmosphere. For a temperature of 300 K, 99.99 % of the power of the terrestrial radiation has a wavelength longer than $3\,000 \times 10^{-9} \text{ m}$ and about 99 per cent longer than $5\,000 \times 10^{-9} \text{ m}$ . For lower temperatures, the spectrum shifts to longer wavelengths (ref: WMO).
World Radiometric Reference (WRR)	Measurement standard representing the SI unit of irradiance with an uncertainty of less than $\pm 0.3 \%$ (see the WMO Guide to Meteorological Instruments and Methods of Observation, 1983, subclause 9.1.3). The reference was adopted by the World Meteorological Organization (WMO) and has been in effect since 1 July 1980 (ref: ISO 9060).

albedo	Ratio of reflected and incoming solar radiation. Dimensionless number that varies between 0 and 1. Typical albedo values are: < 0.1 for water, from 0.1 for wet soils to 0.5 for dry sand, from 0.1 to 0.4 for vegetation, up to 0.9 for fresh snow.
angle of incidence	Angle of radiation relative to the sensor measured from normal incidence (varies from 0° to 90°).
zenith angle	Angle of incidence of radiation, relative to zenith. Equals angle of incidence for horizontally mounted instruments.
azimuth angle	Angle of incidence of radiation, projected in the plane of the sensor surface. Varies from 0 ° to 360 °. 0 is by definition the cable exit direction, also called north, east is +90 ° (ASTM G113-16).
sunshine duration	Sunshine duration during a given period is defined as the sum of that sub-period for which the direct solar irradiance exceeds 120 W/m <sup>2</sup> (ref: WMO).

The IEA SHC #46 and EU FP7 MACC-II projects (Blanc et al. 2014) concluded that the ISO and WMO definitions are insufficiently clear and suggest the following new and refined definitions:

Table 8.11.2 Proposed new and not yet formally accepted pyrliometer-related definitions as suggested by IEA SHC #46 and EU FP7 MACC-II projects, published by Blanc et al. 2014, compared to ISO and WMO.

term	proposed new definition (reference)
pyrheliometer	Radiometer designed for measuring the irradiance which results from the solar radiant flux from a well-defined solid angle the axis of which is perpendicular to the plane receiver surface (ref: WMO).
pyrheliometer	A radiometer designed for measuring the irradiance which results from the solar radiant flux from a well-defined solid angle the axis of which is perpendicular to the plane receiver surface (ref: ISO 9060). Recommended parameters for the view-limiting geometry are a full opening angle of 5 °, and a slope angle of 1 °, and therefore a limit angle of 4 ° (ref: Blanc et al. 2014).
direct solar radiation	DNI, the solar radiant flux collected by a plane unit surface normal to the axis pointing towards the center of the sun, within an optical angular aperture. This aperture is characterized by an acceptance function (ref: Blanc et al. 2014).

direct solar radiation	Radiation received from a small solid angle centered on the sun's disc, on a given plane (ref: ISO 9060).
direct solar radiation from the sun	DNI from the sun, the solar radiant flux collected by a plane unit surface normal to the axis pointing towards center of the sun, within the extent of the solar disk only (half-angle $S = 0.266^\circ \pm 1.7\%$ ), with a perfect radially symmetric rectangular acceptance function (ref: Blanc et al. 2014).
acceptance function	The acceptance function of an optical angular aperture: the fraction of the total radiant flux that is collected by an optical angular aperture, as a function of the off-axis angles. The geometrically perfect acceptance function is equal to one up to the slope angle, and equals zero for off-axis angles larger than the limit angle (ref: Blanc et al. 2014).
pyrheliometer acceptance function	The acceptance function of a pyrheliometer: the fraction of the total radiant flux that is collected by the combination of sensor and optical angular aperture, as a function of the off-axis angles (ref: Blanc et al. 2014).
opening angle	Also full field of view angle: twice the angle between the center of the sensor and the view limiting front aperture (ref: Blanc et al. 2014).
limit angle	The angle from the sensor edge to the view limiting front aperture at the opposite side (ref: Blanc et al. 2014).
slope angle	The angle from the sensor edge to the view limiting front aperture at the same side (ref: Blanc et al. 2014).

## 8.12 Appendix on converting resistance to temperature

DR20 and DR15 are equipped with an internal temperature sensor. This can be either a Pt100 (DR20 / DR15-T1 version) or a 10 kΩ thermistor (DR20 / DR15-T2 version), as ordered.

Both versions require the user to measure the resistance of the temperature sensor and convert this value to temperature. Many data loggers have built-in functions to perform such a conversion. In case the user wishes to calculate temperature (in degrees Celsius) from resistance (in Ohms) himself, there are two distinct procedures:

### DR20 / DR15-T1

T1 versions are equipped with a Pt100 platinum resistance thermometer. It is classified as class A according to DIN EN 60751. It has a resistance of 100 Ω at a temperature of 0 °C.

To convert resistance in Ω to temperature in °C, one can use the following equation:

$$T = \frac{-A + \sqrt{A^2 - 4B \left(1 - \frac{R_{Pt100}}{100}\right)}}{2B} \quad (\text{Formula 8.12.1})$$

with  $R_{Pt100}$  the resistance in Ω, T the temperature in °C, A and B the Pt100 coefficients

$$A = 3.908 \times 10^{-3}$$

$$B = -5.775 \times 10^{-7}$$

### DR20 / DR15-T2

T2 versions are equipped with a 10 kΩ thermistor of type 44031RC. It has a resistance of 10000 Ω at a temperature of 25 °C.

To convert resistance in Ω to temperature in °C, one can use the Steinhart-Hart equation. Measure the resistance of the thermistor and then calculate the temperature from the resistance.

$$T = \frac{1}{\alpha + \beta \ln(R_{\text{thermistor}}) + \gamma \ln(R_{\text{thermistor}})^3} - 273.15 \quad (\text{Formula 8.12.2})$$

with  $R_{\text{thermistor}}$  the thermistor resistance in Ω, T the temperature in °C, α, β and γ the Steinhart-Hart coefficients

$$\alpha = 1.0295 \times 10^{-3}$$

$$\beta = 2.391 \times 10^{-4}$$

$$\gamma = 1.568 \times 10^{-7}$$

## 8.13 Appendix on literature references

1. Blanc et al. (2014), **Direct normal irradiance related definitions and applications; the circumsolar issue**, Solar Energy, Volume December 2014, pp. 561–577
2. ISO (2018), *ISO 9060 Solar energy — Specification and classification of instruments for measuring hemispherical solar and direct solar radiation*, first edition
3. ISO / IEC (1995), **GUIDE 98-3 Uncertainty of measurement — Part 3: Guide to the expression of uncertainty in measurement (GUM:1995)**, also published as JCGM 100:2008, published on internet, accessed 15 JAN, 2014.
4. JCGM (2008), JCGM 200:2008 **International vocabulary of metrology — Basic and general concepts and associated terms (VIM)**, published on internet, accessed 15 JAN, 2014

## 8.14 EU declaration of conformity

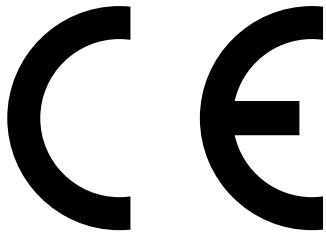

We, Hukseflux Thermal Sensors B.V.,  
Delftechpark 31, 2628 XI, Delft,  
The Netherlands

in accordance with the requirements of the following directives:

2011/65/EU	The Restriction of Hazardous Substances Directive
2014/30/EU	The Electromagnetic Compatibility Directive

hereby declare under our sole responsibility that:

Product models	DR20-A1 and DR15-A1
Product type	Pyrheliometer
Brand name	Hukx

has been designed to comply and is in conformity with the relevant sections and applicable requirements of the following standards:

Emission	EN-IEC 61326-1:2013 for class A equipment
Immunity	EN-IEC 61326-1:2013 using levels for industrial environments

Eric HOEKSEMA  
Director  
Delft, August 20, 2019

## About Hukx

Hukx is the leading innovator in solar radiation and heat flux sensor technology. We are proud to set the standard in high-accuracy measurement, and to be working at the heart of the energy transition.

Customers worldwide rely on our bestselling pyranometers and heat flux sensors. From sensor design and selection to supply and recalibration, we support you across the entire lifecycle.

Hukx is headquartered in the Netherlands, with locally owned representative sales offices in the USA, Brazil, India, China, Southeast Asia, and Japan.

Let us help you select the best sensor for your application. Get in touch with our experts today via: [info@hukx.com](mailto:info@hukx.com)

© Hukx

v2509

We reserve the right to change specifications without prior notice.

[www.hukx.com](http://www.hukx.com)

**HUKX**