

HUKX

Sensor
Technology

Brochure
Analog Class A & B
pyrheliometers

DR20-A1
DR15-A1

DR20-A1 & DR15-A1 Analog Class A & B pyrheliometers

with heating

DR20-A1 and DR15-A1 are high-accuracy, direct (normal incidence) solar radiation sensors, also known as pyrheliometers. DR20-A1 complies with Class A and DR15-A1 with Class B specifications of the ISO 9060:2018 standard. These instruments are designed for tracker-mounted operation and offer analog millivolt outputs. Both pyrheliometers have superior window heating that leads to high data availability by mitigating dew and frost.

Hukx's [DR15-A1](#) pyrheliometer is an ISO 9060 spectrally flat Class B instrument and replaces the older DR01, DR02, and DR03 models. [DR20-A1](#) is a new Class A instrument with an improved temperature response compared to DR15-A1. Both instruments offer the highest accuracy and data availability, featuring window heating at low offsets. At the same heating power, the heating has been improved by a factor of 4, at just a quarter of the offset!

DR20-A1 and DR15-A1 are engineered for high-accuracy measurement of direct solar radiation—also known as Direct Normal Irradiance (DNI)—received by a plane surface from a 5° full field of view angle. DNI is expressed in W/m^2 . For optimal results, the instrument must be mounted on a two-axis tracker to stay pointed at the sun.

Figure 1 DR20 Class A / DR15 Class B pyrheliometer: the external housing of these instruments is identical.



Heated for high data availability

High data availability is attained by heating the front window, which suppresses dew and frost deposition at a very low power consumption. DR20-A1 and DR15-A1 only require 1W to keep their window free from dew and frost.

Liabilities covered: test certificates

As required by ISO 9060 for Class A classification, each DR20-A1 is supplied with test results for the individual instrument:

- sensitivity
- response time
- temperature response

DR15-A1 certificates include sensitivity and response time only.

DR20-A1 and DR15-A1 use

A pyrheliometer is designed for tracker-mounted operation. DR20-A1 and DR15-A1 connect directly to commonly used data logging systems and offer analog outputs in the millivolt range.

DR20-A1 and DR15-A1 design

The pyrheliometer features a precision-ground and polished quartz window, a compact collimated tube, and a thermopile sensor with a black-coated surface.



Figure 2 The importance of heating: tracker-mounted operation of heated DR20-A1 and DR15-A1 pyrheliometers being installed with heated SR15-A1 pyranometers. The data availability of non-heated instruments suffers in almost all environments due to morning dew and frost.

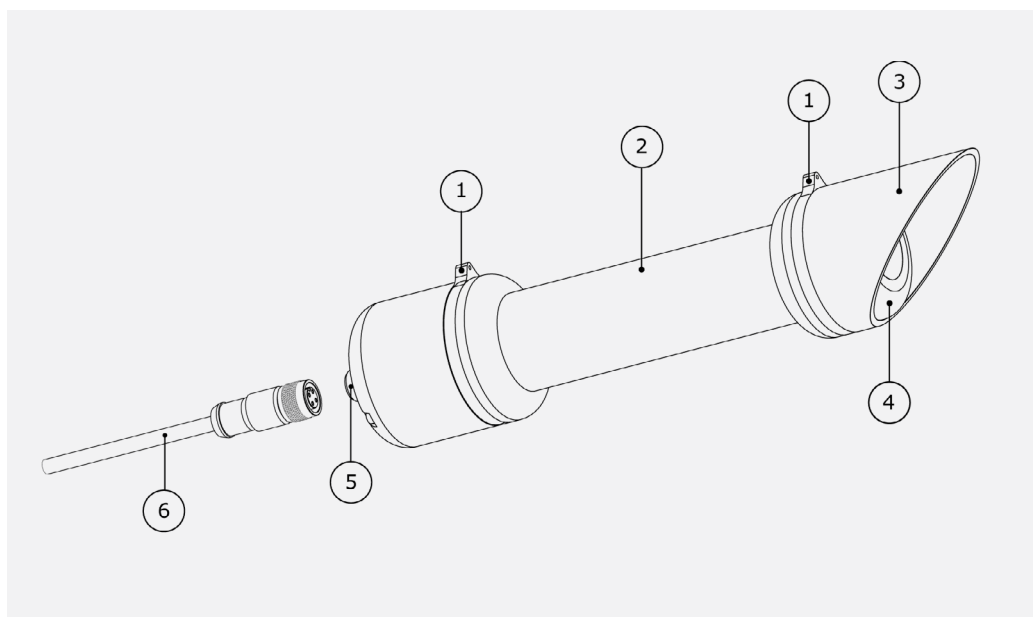

Figure 3 Overview of DR20-A1 / DR15-A1
1. sights
2. aperture tube
3. protection cap
4. window assembly with heater
5. connector
6. cable

Suggested use

- solar energy surveys
- solar resource assessments
- meteorological networks
- sites with dew and frost issues

Uncertainty evaluation

The uncertainty of a measurement under outdoor conditions depends on many factors. Guidelines for uncertainty evaluation (according to the "Guide to Expression of Uncertainty in Measurement" or GUM) can be found in our manuals.

We provide spreadsheets to assist you in evaluating the uncertainty of your measurements.



Figure 4 DR20-A1 / DR15-A1 pyrheliometer side view.

See also

- [DR30-D1 digital pyrheliometer](#) with heating, internal tilt sensor, and humidity measurement
- View our complete [product range of sensors](#).



Figure 5 DR20-A1 / DR15-A1 pyrheliometer front view.

DR20-A1 and DR15-A1 user benefits

Using DR20-A1 / DR15-A1 pyrheliometers offers significant benefits over competing models. The pyrheliometers offer the highest accuracy and data availability, featuring heating at low offsets. The advantages of having a heater are demonstrated in the following graphs:

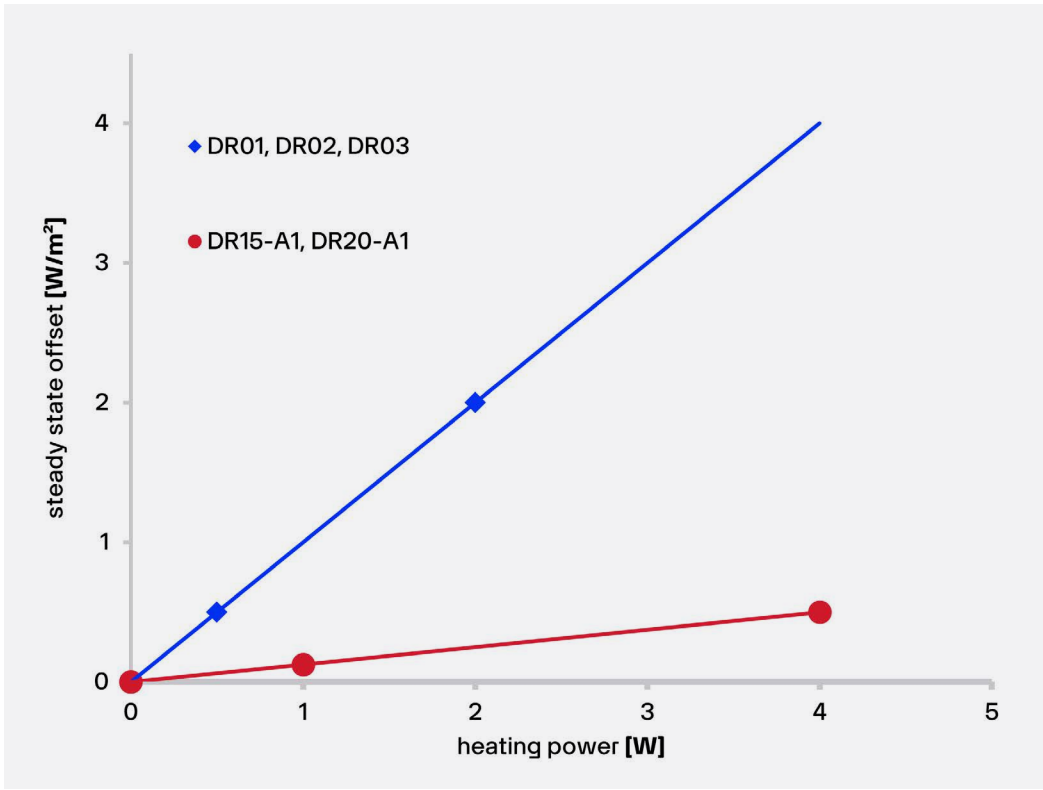

Figure 6 The offset of the latest models DR20-A1, DR15-A1 (and also the digital DR30-D1) when heating is significantly improved compared to the older DR01, DR02, and DR03 models. DR20-A1 and DR15-A1 have a 12 VDC, 1W heater, which produces a negligible offset. The older models had offsets of the order of 1 W/m^2 at the same heating level. In addition, the temperature of the front window of DR20-A1 and DR15-A1 is 4 times higher than that of the older models, at the same heating power.

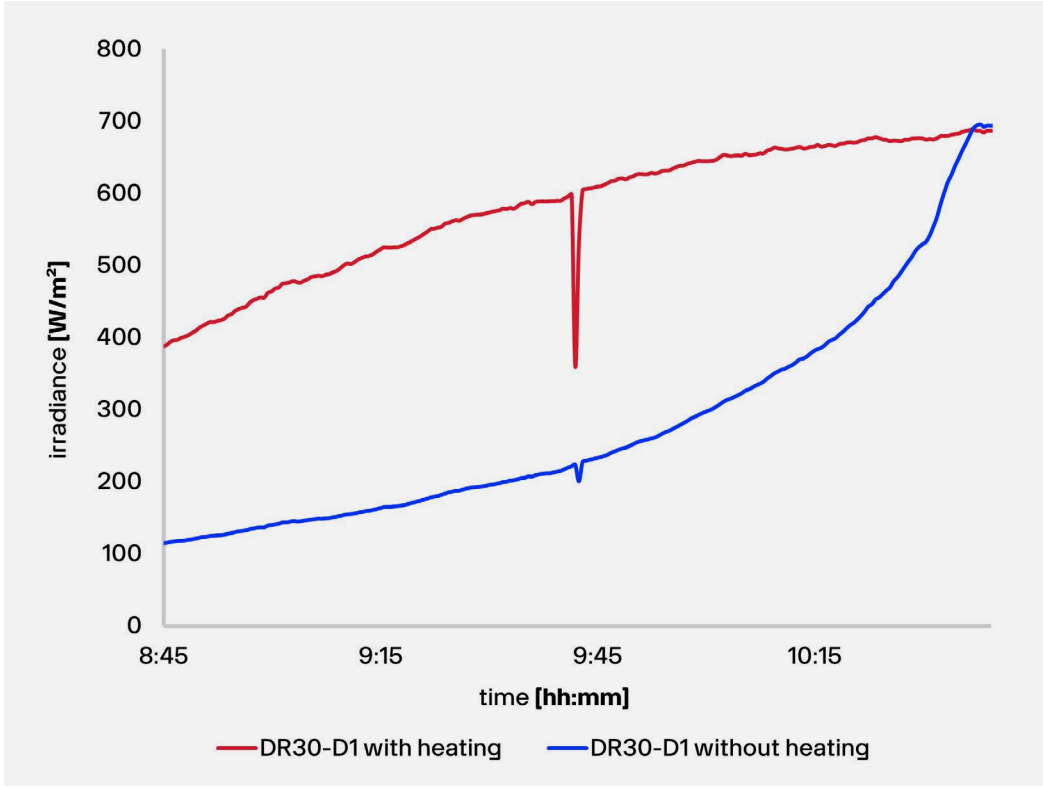

Figure 7 Comparison of the measured data with and without heating on a typical winter morning using model DR30-D1, which has the same heating as DR20-A1 and DR15-A1. The unheated DR30-D1 has dew on its front window, which causes a significant underestimation of incoming irradiance. At around 10:30, the dew evaporates. Real measured data from Delft, the Netherlands.

DR20-A1 and DR15-A1 specifications

General specifications

measurand direct solar radiation

ISO classification spectrally flat
pyrheliometer
DR20-A1: Class A
DR15-A1: Class B

calibration uncertainty < 1.2 % (k = 2)

heating included

heater 1W at 12 VDC

response time (95 %) 4 s

full field of view angle 5 °

slope angle 1 °

zero offset a (5 K/hr) < ± 1 W/m²

calibration traceability to WRR

analog output millivolt

spectral range 200 to 4000 x 10⁻⁹ m

rated operating
temperature range -40 to +80 °C

temperature response DR20-A1:
< ± 0.5 % (-10 to +40 °C)

with correction in data
processing:
< ± 0.4 % (-30 to +50 °C)

DR15-A1:
< ± 1 % (-10 to +40 °C)

calibration certificate included

temperature response
test of individual
instrument DR20-A1: report
included
DR15-A1: no report

standard cable length 5 m

About Hukx

Hukx is the leading innovator in solar radiation and heat flux sensor technology. We are proud to set the standard in high-accuracy measurement, and to be working at the heart of the energy transition.

Customers worldwide rely on our bestselling pyranometers, pyrhemometers, and heat flux sensors. From sensor design and selection to supply and recalibration, we support you across the entire lifecycle.

Hukx is headquartered in the Netherlands, with locally owned representative sales offices in the USA, Brazil, India, China, Southeast Asia, and Japan.

Let us help you select the best sensor for your application. Get in touch with our experts today via: info@hukx.com

© Hukx

Version 2510

We reserve the right to change specifications without prior notice.

www.hukx.com

HUKX