

HUKX

Sensor
Technology

User manual
Crossarm mounting fixture
for pyranometers

CMF01

Warning statements



When using CMF01's tube clamps, tightening of the tube clamp should not exceed 6 Nm.

Contents

Introduction	4
1 Ordering and checking at delivery	7
1.1 Ordering CMF01 crossarm mounting fixture	7
1.2 Included items	7
2 Specifications of CMF01	8
2.1 Specifications of CMF01 crossarm mounting fixture	8
2.2 Dimensions of CMF01	9
3 Installation of CMF01	10
3.1 Site selection and installation	10
3.2 Tooling required for CMF01	10
3.3 Crossarm on mast mounting installation	10

Introduction

Hukx offers a full range of practical brackets for mounting atmospheric radiation sensors in all climates and weather conditions. CMF01 is a versatile fixture allowing mounting a crossarm onto a vertical mast. It is typically used with SR300, SR200, SR100, SR30, SR15 and SR05 pyranometers with their mounting fixtures. It can also be used in combination with NR01 net radiometers, SRA series albedometers and with PMF01 pyranometer mounting fixture.

CMF01 is a practical mounting fixture for mounting a crossarm. The purpose of the crossarm is to mount radiometers on a mast. The crossarm may serve to mount multiple instruments. The crossarm also creates some distance between radiometer and mast, so that the mast does not cast a shadow and does not reflect radiation onto the instrument. A typical distance between mast and radiometer is 1.5 m.

Most crossarms used in radiometry are mounted in the north-south direction so that the radiometer can be mounted towards the equator and a mast extending above the crossarm does not cast a shadow on the instrument.

In PV monitoring we also see crossarms oriented in the east-west direction to mount instruments for Global Horizontal Irradiance (GHI), Plane of Array Irradiance (POA) and Reflected Horizontal Irradiance (RHI).

CMF01 offers several advantages:

- quick installation
- strong mast-to-crossarm connection
- can carry multiple instruments

Figure 01 An albedometer being installed with its rod mounted securely to a mast thanks to ALF01 leveling fixture and CMF01 crossarm mounting fixture



Suggested use for CMF01:

- meteorological observations
- PV monitoring

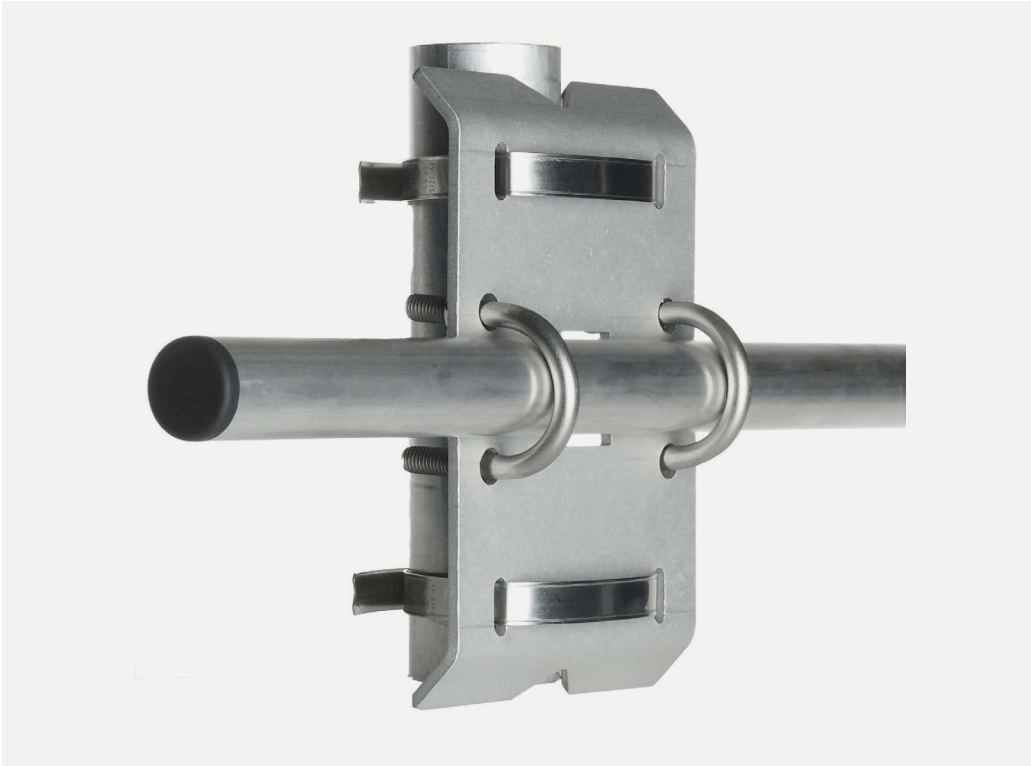

Figure 0.2 CMF01 crossarm mounting fixture, shown with a crossarm mounted on a mast.

CMF01 is made of high-quality metals, allowing installations in all climates and weather conditions. It is delivered with u-bolts and tube clamps. The user should provide his own crossarm and instrument(s). The latter can be ordered separately at Hukx.

There are other Hukx mounting options available for SR300, SR200, SR100, SR30, SR15 and SR05 pyranometers. They allow for simplified mounting, leveling and instrument exchange on a flat surface or a tube, such as a crossarm. These mounts, complementary to CMF01, are optional with the purchase of these instruments. Alternatively, PMF01 and PMF02 brackets may be used for mounting any Hukx pyranometer on a mast, crossarm or other mounting platform.



Figure 0.3 Complementary mounting options are offered for SR300, SR200, SR100, SR30, SR15 and SR05 sensors.

Please also refer to the user manual of your pyranometer, albedometer or net radiometer for a proper installation of that particular instrument with a CMF01 crossarm mounting fixture. The instrument should be used in accordance with the recommended practices of ISO, IEC, WMO and ASTM.

See also:

- SR300, SR200, SR100 pyranometers with spring-loaded and tube leveling mount
- SR30 and SR15 pyranometers with spring-loaded and tube leveling mount
- SR05 second class with ball leveling and tube mount
- SRA series albedometers
- ALF01 albedometer leveling fixture
- NR01 net radiometer
- PMF01 and PMF02 pyranometer mounting fixtures
- view our complete range of solar radiation sensors

1 Ordering and checking at delivery

1.1 Ordering CMF01 crossarm mounting fixture

CMF01 is an accessory for use with pyranometers, albedometers and net radiometers. The ordering code is CMF01.

1.2 Included items

Arriving at the customer, the delivery should include:

– CMF01 crossarm mounting fixture including:

- bracket
- 2 x tube clamp
- 2 x U bolt
- 4 x M8 nut

2 Specifications of CMF01

2.1 Specifications of CMF01 crossarm mounting fixture

CMF01 is a practical mounting fixture for mounting a crossarm. The purpose of the crossarm is to mount radiometers on a mast. The crossarm may serve to mount multiple instruments.

Please also refer to the user manual of your pyranometer, albedometer and/or net radiometer for a proper installation of that particular instrument with CMF01 crossarm mounting fixture. The instrument should be used in accordance with the recommended practices of ISO, IEC, WMO and ASTM.

Table 2.1.1 Specifications of CMF01.

CMF01 general specifications	
product type	bracket
instrument compatibility	pyranometers, albedometers and net radiometers
material	anodised aluminum (tube clamps and bolts also made of stainless steel)
rated operating temperature	-40 to +80 °C
included parts	bracket 2 x tube clamp 2 x U bolt 4 x M8 nut
not included	mast, crossarm and instrument(s)
mast compatibility	1 inch pipe length < 1.5 m
maximum weight on CMF01 (at crossarm length of 1.5 m)	approx. 2.5 kg
CMF01 transport	
gross weight	approx. 0.5 kg
net weight	approx. 0.5 kg

2.2 Dimensions of CMF01

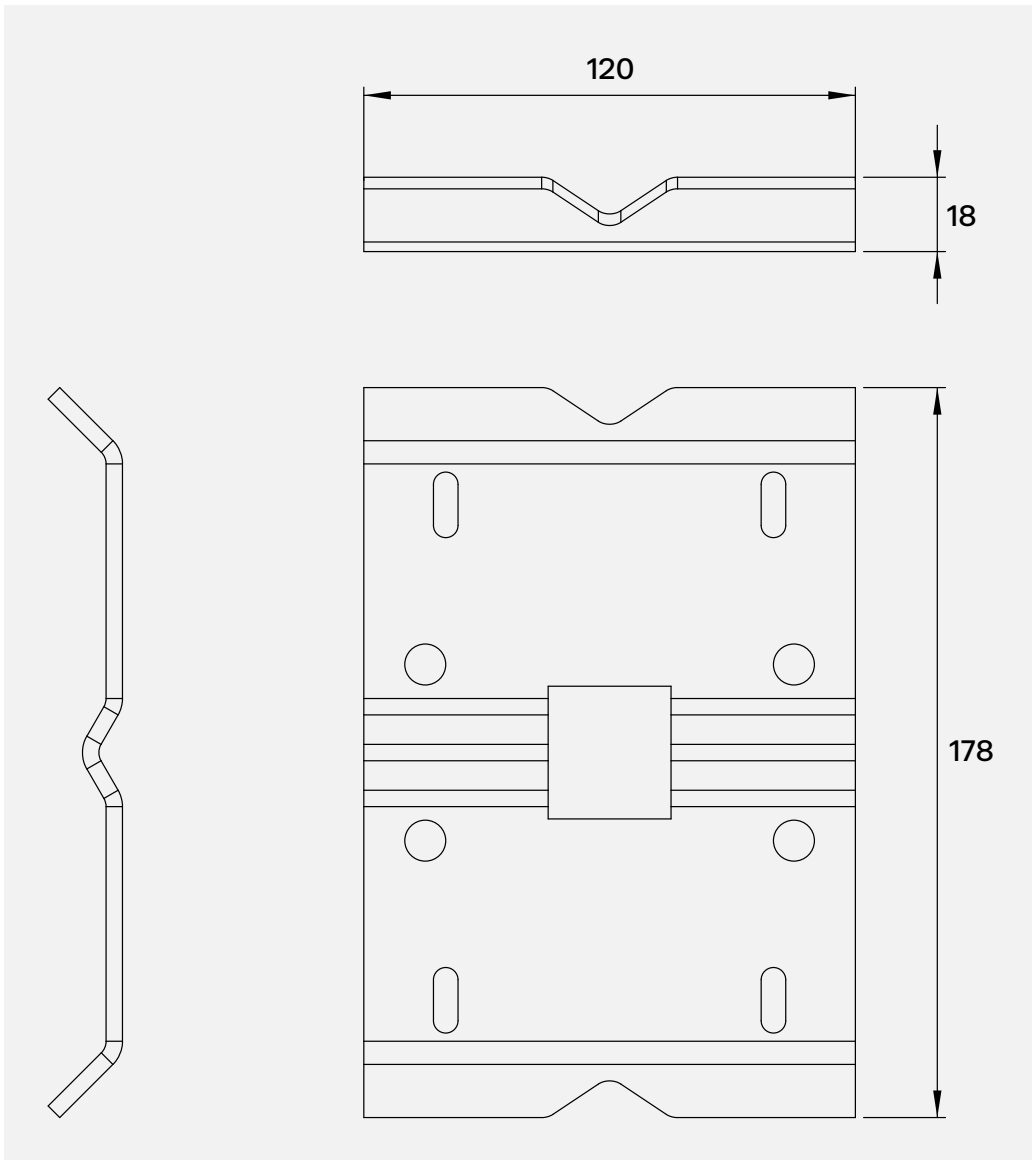

Figure 2.2.1 Dimensions of CMF01 in 10^{-3} .

3 Installation of CMF01

3.1 Site selection and installation

Please refer to the user manual of your pyranometer, albedometer and/or net radiometer for a proper installation of that particular instrument with CMF01 crossarm mounting fixture. The instrument should be used in accordance with the recommended practices of ISO, IEC, WMO and ASTM.

3.2 Tooling required for CMF01

Table 3.2.1 Specifications of tools for CMF01 (not included with CMF01).

tooling required for CMF01	7 mm socket wrench 13 mm spanner
----------------------------	-------------------------------------

3.3 Crossarm on mast mounting installation

When mounting a crossarm, or a similar horizontal tube or rod, onto a mast with CMF01 crossarm mounting fixture, please follow the instructions below:

1. Put the two tube clamps through the designated holes of CMF01 and mount the bracket onto the vertical mast by tightening the clamps. Use a 7 mm socket wrench, or alternatively, a flathead screwdriver.

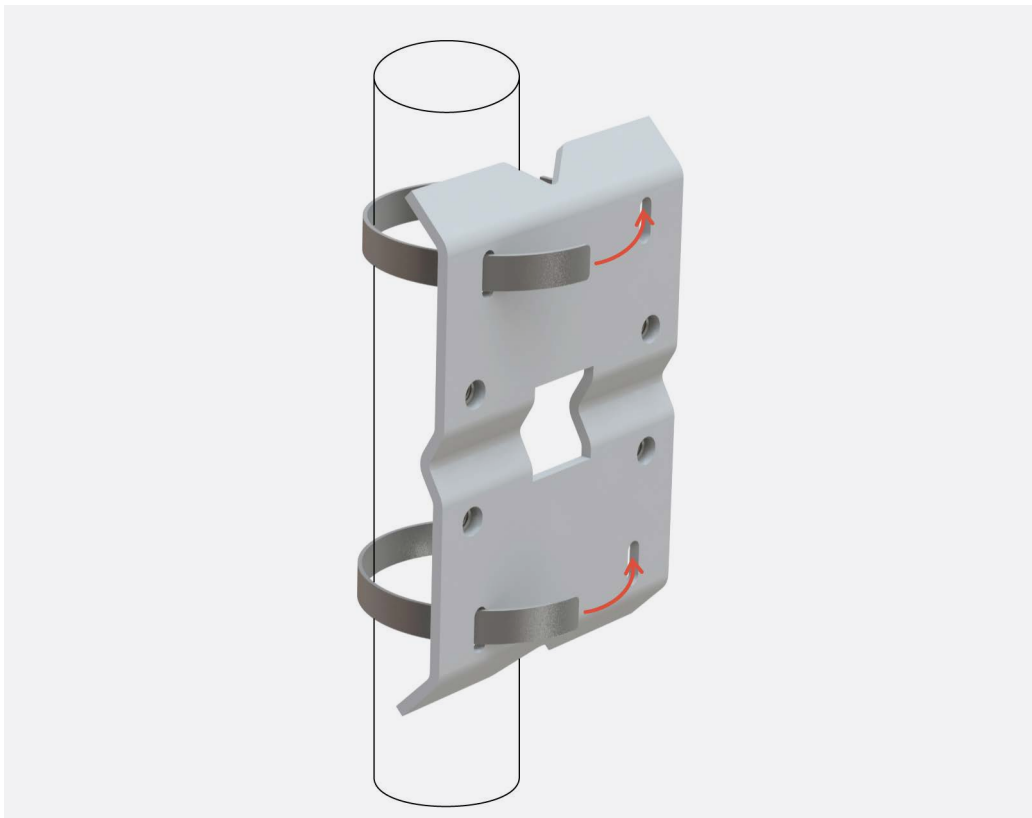

Figure 3.3.1 Step 1: installation of CMF01 on a vertical mast.

- Put the two U-bolts through the designated round holes and (loosely) tighten them using the four nuts. Use a 13 mm spanner. Slide the crossarm through the two U bolts. When the crossarm is in its desired position, tighten both U-bolts securely.

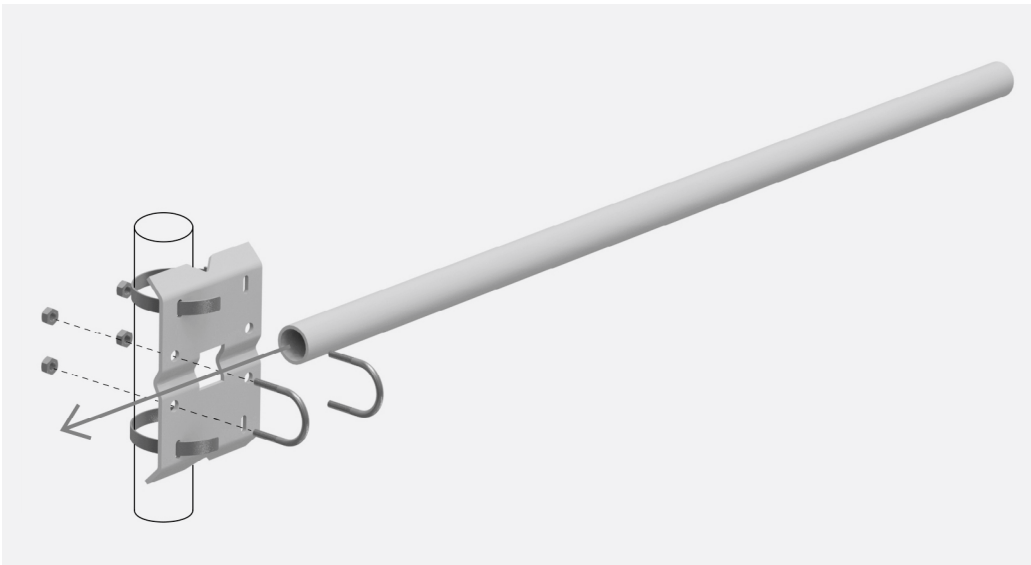

Figure 3.2.2 Step 2: installation of a horizontal crossarm onto CMF01.

- Once the crossarm is securely connected to the mast, mount the instrument(s) of your choice onto the crossarm. Level the sensor(s). See the user manual(s) of your instrument(s) for possible further instructions, for example on installations of screen caps and cabling.

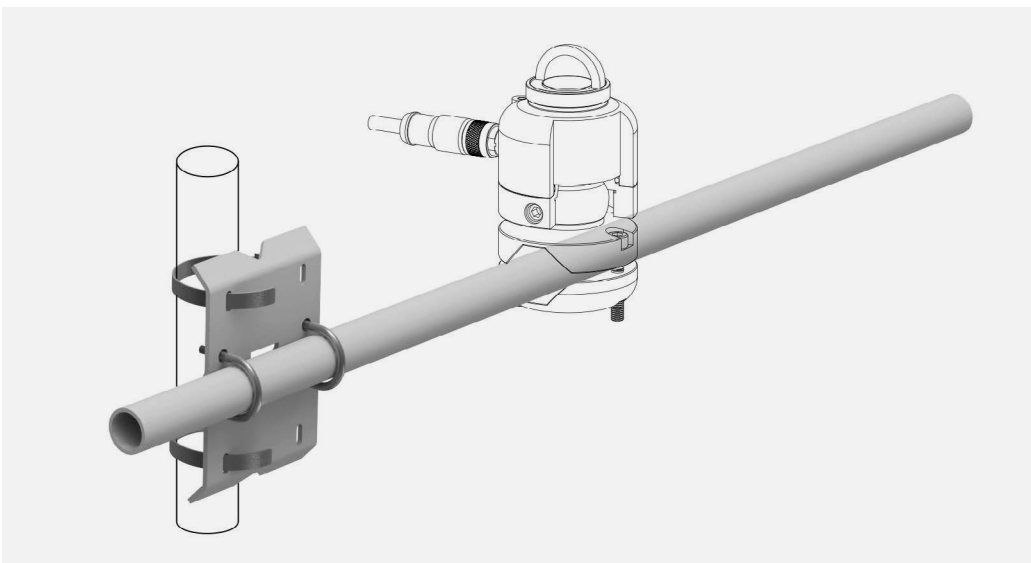

Figure 3.3.3 Step 3: installation of a radiometer on a crossarm, mounted with CMF01 on a mast. Pyranometer model SR05 with tube leveling is shown as an example.

About Hukx

Hukx is the leading innovator in solar radiation and heat flux sensor technology. We are proud to set the standard in high-accuracy measurement, and to be working at the heart of the energy transition.

Customers worldwide rely on our bestselling pyranometers and heat flux sensors. From sensor design and selection to supply and recalibration, we support you across the entire lifecycle.

Hukx is headquartered in the Netherlands, with locally owned representative sales offices in the USA, Brazil, India, China, Southeast Asia, and Japan.

Let us help you select the best sensor for your application. Get in touch with our experts today via: info@hukx.com

© Hukx

Version 2605

We reserve the right to change specifications without prior notice.

www.hukx.com

HUKX